

2024

Rules for the Classification of Steel Ships

Part 2 Materials and Welding

---

---

Rules

2024

Guidance Relating to the Rules for the Classification of Steel Ships

Part 2 Materials and Welding

---

---

Guidance



2024

Rules for the Classification of Steel Ships

---

Part 2

Materials and Welding

---

## **Amendments to the Rules for the Classification of Steel Ships**

1. Unless expressly specified otherwise, the requirements in these Rules apply to ships/offshore contracted for construction on or after 1 July 2024 or when the application for certification of materials and welding is dated on or after 1 July 2024.
2. The amendments to the Rules for 2023 edition and their effective date are as follows;

Effective Date 18 September 2023(Applicable retroactively after 1 July 2023) (based on the contract date for ships/offshore construction or the application date for certification of material and welding, Related Circular No. : 2023-11-E)

---

### **CHAPTER 1 MATERIALS**

#### **Section 5 Castings**

- 501. 7 (1) has been amended.
- 501. 7 (2), (3) and (4) have been deleted.

Effective Date 1 July 2024 (based on the application date for certification of materials and welding)

---

### **CHAPTER 1 MATERIALS**

#### **Section 3 Rolled Steels**

- 301. 3 (1) has been amended.
- Table 2.1.45 of 312. 4 has been amended.

#### **Section 5 Castings**

- 501. 6 (2) has been deleted.
- 501. 13 (3) has been deleted.

### **CHAPTER 2 WELDING**

#### **Section 6 Welding Consumables**

- 601. 5 has been amended.
- 601. 10 (2) (d) has been amended.

# CONTENTS

<b>CHAPTER 1 MATERIALS</b> .....	<b>1</b>
Section 1 General .....	1
101. Application .....	1
102. Approval of manufacturing process and manufacturing control .....	1
103. Chemical composition .....	1
104. Testing and inspection .....	2
105. Execution of testing and inspection .....	2
106. Identification of materials .....	2
107. Test certificates .....	2
108. Quality and repair of defects .....	3
109. Retest procedures .....	3
110. Marking .....	4
Section 2 Test Specimens and Testing Procedures .....	5
201. General .....	5
202. Form and dimension of test specimen .....	5
203. Testing procedure .....	10
Section 3 Rolled Steels .....	11
301. Rolled steels for hull structural .....	11
302. Rolled steel plates for boiler .....	23
303. Rolled steel plates for pressure vessel .....	25
304. Rolled steels for low temperature service .....	28
305. Rolled stainless steels .....	32
306. Round bars for chain .....	35
307. Rolled steel bars for boiler .....	38
308. High strength steels for welded structures .....	39
309. Stainless clad steel plates .....	46
310. Additional requirements for through thickness properties .....	49
311. YP47 Steels .....	52
312. Brittle crack arrest steels .....	54
Section 4 Steel Tubes and Pipes .....	56
401. Steel tubes for boilers and heat exchangers .....	56
402. Steel pipes for pressure piping .....	60
403. Stainless steel pipes .....	66
404. Steel pipes for low temperature service .....	69
405. Header .....	72
Section 5 Castings .....	75
501. Steel castings .....	75
502. Steel castings for chains .....	83
503. Stainless steel castings .....	84
504. Steel castings for low temperature service .....	86

505. Stainless steel casting for propeller .....	87
506. Grey iron castings .....	90
507. Spheroidal or nodular graphite iron castings .....	92
Section 6 Steel Forgings .....	97
601. Steel forgings .....	97
602. Stainless steel forgings .....	111
603. Steel forgings for chains .....	112
604. Steel forgings for low temperature service .....	114
Section 7 Copper and Copper Alloy .....	116
701. Copper and copper alloy pipes and tubes .....	116
702. Copper alloy castings .....	117
Section 8 Aluminium Alloys .....	122
801. Aluminium alloys .....	122
802. Aluminium/steel transition joints .....	128
<b>CHAPTER 2 WELDING .....</b>	<b>131</b>
Section 1 General .....	131
101. Application .....	131
102. Matters to be approved .....	131
103. Special weldings .....	131
104. Terms and definitions .....	131
Section 2 Test Specimens and Testing Procedures .....	132
201. General .....	132
202. Selection of test specimens .....	132
203. Size and dimensions of test specimens .....	132
204. Mechanical testing procedures .....	136
Section 3 Welding Work and Inspection .....	137
301. Details of joints .....	137
302. Welding Practice .....	138
303. Application of welding consumables .....	138
304. Preparation for Welding .....	138
305. Welding sequence and direction of welding .....	140
306. Main welding .....	140
307. Automatic welding .....	141
308. Welding for higher strength steel .....	141
309. Quality of welds .....	141
310. Repairs .....	141
311. Welding works for YP47 Steels .....	141
312. Welding works for Brittle crack arrest steels .....	142
Section 4 Welding Procedure Qualification Tests .....	143
401. General .....	143
402. Welding procedure specification .....	143
403. Welding procedure qualification tests(WPQT) .....	144

404. Tests for butt welded joints .....	144
405. Tests for fillet welded joints .....	157
406. Retests and Procedure qualification records(PQR) .....	160
407. Validity of qualified welding procedure specification .....	161
Section 5 Welders and Welder Performance Qualification Scheme .....	167
501. General .....	167
502. Grades, and range of qualification .....	167
503. Testing procedure .....	176
504. General requirements for qualification validity .....	180
Section 6 Welding Consumables .....	182
601. General .....	182
602. Electrodes for manual arc welding for normal strength steels, higher strength steels and steels for low temperature service ..	184
603. Automatic welding consumables for normal strength steels, higher strength steels and steels for low temperature service ..	195
604. Semi-automatic welding consumables for normal strength steels, higher strength steels and steels for low temperature service ..	207
605. Electro-slag and electro-gas welding consumables .....	213
606. One side welding consumables for normal strength steels, higher strength steels and steels for low temperature service. ·	217
607. Welding consumables for stainless steel .....	222
608. Welding consumables for aluminium alloys .....	232
609. Welding consumables for weldable high strength steels .....	236

## CHAPTER 1 MATERIALS

### Section 1 General

#### 101. Application **[See Guidance]**

1. The requirements in this Chapter apply to the materials intended to be used for the components specified in each Part of hull construction, equipment and machinery.
2. The materials other than those prescribed in this Chapter may be used where specially approved in connection with the design. In such cases, the detailed data relating to the chemical compositions and mechanical properties, etc. of the materials are to be submitted for approval.
3. Reinforced plastic materials used for construction or repair of FRP ships or composite vessel should be in accordance with the Guidance relating to the Rules specified by the Society. (2017)

#### 102. Approval of manufacturing process and manufacturing control

##### 1. Approval of manufacturing process

- (1) The materials prescribed in this Chapter, unless otherwise specially provided, are to be manufactured by open-hearth, electric furnace, basic oxygen processes, or other processes at works approved by the Society. In this case, the manufacturer is to obtain the approval in accordance with the Guidance specially specified by the Society in advance concerning the process of manufacture (melting process, ingot casting, rolling, casting, forging and heat treating).
- (2) The manufacturing process of semi-finished products such as ingots, slabs, blooms and billets for the normal and higher strength hull structural steels or forgings are to be approved in accordance with the Guidance specially specified by the Society in advance
- (3) The rolled steel manufacturer supplied semi-finished products from other steel works or hot coil processor is required to obtain the approval of the manufacturing process according to the requirement of proceeding (1) as appropriate.
- (4) The requirements specified in Pars (1) and (2) may be applied to the non-ferrous material prescribed in this Chapter.

##### 2. Manufacturing control

- (1) It is the manufacturer's responsibility to assure that effective process and production controls in operation are adhered to within the manufacturing specifications.
- (2) Where control imperfection inducing possible inferior quality of product occurs, the manufacturer is to identify the cause and establish a countermeasure to prevent its recurrence. Also, the complete investigation report is to be submitted to the Surveyor. **[See Guidance]**
- (3) For further use, each product affected by previous (2) is to be tested to the Surveyor's satisfaction. The frequency of testing for subsequent products offered may be increased to gain confidence in the quality at the discretion of the Society. **[See Guidance]**
- (4) When steel is not produced at the works at which it is rolled, a certificate is to be supplied to the Surveyor at the rolling mill stating the process by which it was manufactured, the name of the manufacturer who supplied it, the number of the cast from which it was made and the ladle analysis. The Surveyor is to have access to the works at which the steel was produced.

#### 103. Chemical composition

1. The chemical composition of samples taken from each ladle of each cast is to be determined by the manufacturer in an adequately equipped and competently staffed laboratory and is to comply with the appropriate requirements for chemical composition provided in this Chapter. **[See Guidance]**
2. The Manufacturer's declared analysis will be accepted subject to occasional checks if required by the Surveyor. **[See Guidance]**
3. Product analysis may be required where the final product chemistry is not well represented by the analysis from the cast. **[See Guidance]**

#### 104. Testing and inspection

1. The materials are to be tested and inspected in the presence of the Society's Surveyor except otherwise specially provided, and are to comply with the requirements in this Chapter.
2. The materials other than those prescribed in this Chapter are to be tested and inspected according to the specification for the testing approved in accordance with the requirements in **101. 2**.
3. The Society may accept to omit the tests for materials having the appropriate certificates.
4. Where the materials are manufactured by the approval of quality assurance scheme specially specified by the Society, a part or all of test and inspection in the presence of the Society's Surveyor may be omitted. **[See Guidance]**

#### 105. Execution of testing and inspection

1. The manufacturers shall afford the Surveyor all necessary facilities and access to all relevant parts of the works to enable him to verify that the approved process is adhered to, for the selection of test materials, and the witnessing of tests, as required by the Rules, and for verifying the accuracy of the testing equipment.
2. All tests and inspections are to be carried out at the place of manufacture before dispatch. The test specimens and procedures are to be in accordance with **Sec 2** of this chapter. All the test specimens are to be selected and stamped by the Surveyor and tested in his presence, unless otherwise agreed.
3. In the case of special order, the manufacturer is to show the order specifications, special requirements, etc. of the materials to the Surveyor prior to the material test.
4. Surface inspection and verification of dimensions are the responsibility of the steel maker. The acceptance by the Surveyor shall not absolve the steel maker from this responsibility.

#### 106. Identification of materials

1. The manufacturer is to take a suitable measure for the identification of ingots, slabs, castings, forgings, and finished pieces, etc. which will enable the material to be traced to its original heat, roll, etc.
2. The steelmaker is to adopt a system for the identification of ingots, slabs and finished pieces which will enable the material to be traced to its original cast. The Surveyor is to be given full facilities for so tracing the material when required.
3. Where small products such as castings are manufactured in large numbers, modified arrangements for identification may be specially agreed with the Society.

#### 107. Test certificates (2017) **[See Guidance]**

1. The Certificate for Materials Inspection is to be issued to the materials by the Society that have been satisfactorily tested and inspected in accordance with the requirements in this Chapter.
2. Notwithstanding the previous provisions, the accepted material with large quantity production such as rolled steels, etc. may be omitted the issue of the Certificate for Materials Inspection where the manufacturer supplies the Mill Sheets for each accepted steel grade to the Surveyor for his signature. In this case, the manufacturer is to enter the following statement on the certificate to show that the steel material has been made by an approval process and that it has withstand satisfactory the required tests. The following form of declaration will be accepted if stamped or printed on each test certificate with the name of the steel works in English or Korean, and is to be signed by the personnel of the manufacturing shop in charge of product quality assurance or inspector.  
  
"We hereby certify that the material has been made by an approval process and has been satisfactorily tested in accordance with the Rules of Korean Register."  
  
3. The Certificate for Materials Inspection issued by manufacturer is to contain at least the following particulars;



- (1) Sheet(Certificate) number
  - (2) Purchaser's name
  - (3) purchaser's order number
  - (4) If known the hull number for which the material is intended.
  - (5) Identification of the steelworks.
  - (6) Material grade mark
  - (7) Dimension of products and drawing number
  - (8) Identification number for tracing piece to heat(cast)
  - (9) Chemical composition (All required elements with residual and intentionally added elements))
  - (10) Mechanical properties test results, including traceable test identification
  - (11) Condition of heat treatment, if applicable
  - (12) Other specific requirements
4. The manufacturer is to keep the test certificates more than 10 years from the supply date of products for identification and handling. (2019)

### 108. Quality and repair of defects

1. All materials are to be free from surface or internal defects which would be prejudicial to their proper application in service. The surface finish is to be in accordance with good practice and any specific requirements of the approved plan.
2. In the event of any material proving unsatisfactory during subsequent working or fabrication, such material may be rejected, notwithstanding any previous satisfactory testing and/or certification where the Surveyor considers necessary.
3. Welding or other means for the purpose of repairing defects is not permitted, unless the extent and method of repair (including welding procedure and heat treatment) are approved by the Surveyor. The repair of defects is to be carried out in the presence of the Surveyor, unless otherwise agreed.
4. Where repair by grinding is carried out then the remaining plate thickness below the ground area must be within the allowable under thickness tolerance.

### 109. Retest procedures


1. Where a part of the results of any test except impact test does not comply with the requirements, but the remainders are satisfactory, additional test specimens twice in number may be taken from the same material and retests for the failed test may be carried out. In such a case, all of the test specimens are to comply with the requirements.

#### 2. Impact test

- (1) Where the result of the impact test is unsatisfactory, additional tests may be carried out, with the exception of the cases specified in (i) and (ii) below, by taking a set of test specimens out of the same piece from which the above-mentioned test specimens have been taken.
  - (i) The absorbed energy of all test specimens is under the required average absorbed energy.
  - (ii) The absorbed energy of two of the test specimens is under 70 % the required average absorbed energy.
- (2) In case of the previous (1), all pieces of the same lot from which the test specimens have been taken, may be accepted, provided that the average absorbed energy of the six test specimens, including those which have been rejected as unsatisfactory, is not less than the required average absorbed energy, and that not more than two individual results are lower than the required average absorbed energy and of these, not more than one result is below 70 % of the required average absorbed energy.
3. If a heat treated material fails to meet the requirements in any test, retest and heat treatment may be allowed two times(three times including the first test) with the same number of specimens as the initial test. In this case, however, the material is not to be considered as having complied with the requirements, unless all tests fully comply with the test requirements. (2018)
4. If the percentage of elongation of any tension test specimen is less than that specified and any part of fracture is outside the one-fourth of the gauge length from the centre of gauge length, the test is to be considered as invalid, and a retest for the material from which the first test specimen has

been taken may be allowed. **[See Guidance]**

### 110. Marking

1. Every material complying with the requirements is to be clearly stamped with the Society's brand  and material grade mark, and marked with the following particulars at least in one position by the maker:
  - (1) Name or mark to identify the steel works.
  - (2) Number or mark to identify the material.
  - (3) Name or mark to identify the purchaser. (if required by the purchaser)
2. Materials which have been specially approved by the Society in accordance with the requirements in **101. 2** are to have the letter "S" after the material grade mark.
3. Materials which are unsuitable for stamping may be marked with brands, seals or by other suitable means.
4. The marking particulars, but excluding the manufacturer's name or trade mark where this is embossed on finished products are to be encircled with paint or otherwise marked so as to be easily recognizable.
5. Materials which can not be stamped and marked in accordance with the requirements in **Pars 1** and **2** due to small size may be properly marked in the lump.
6. Where a number of light materials are securely fastened together in bundles the manufacturer may, subject to the agreement of the Society, brand only the top piece of each bundle, or alternatively, a firmly fastened durable label containing the brand may be attached to each bundle.
7. In the event of any material bearing the Society's brand failing to comply with the test requirements, the brand is to be unmistakably defaced by the manufacturer.

## Section 2 Test Specimens and Testing Procedures

### 201. General

#### 1. Application

- (1) Test specimens and mechanical testing procedures for materials are to comply with the requirements of this Section, unless otherwise specially provided in each Section.
- (2) Where test specimens and testing procedures differing from those prescribed in this Section are used, they are to be approved by the Society. **【See Guidance】**

#### 2. Testing machine

- (1) The testing machines used for the tests relative to this Chapter are to be managed by competent personnel on machines.
- (2) Tension/compression testing machines are to be calibrated in accordance with *ISO 7500-1:2018* or other recognised standard. (2023) **【See Guidance】**
- (3) Impact testing machines are to be calibrated in accordance with *ISO 148-2:2016* or other recognised standard. (2023) **【See Guidance】**
- (4) The accuracy of tensile test machines is to be within  $\pm 1\%$

#### 3. Selection of test specimens

- (1) The test specimens are to be selected according to each requirement in this Chapter.
- (2) Except where otherwise specified or agreed with the Surveyor, test samples are not to be detached from the material until being stamped by the Surveyor. **【See Guidance】**
- (3) If test samples are cut from material by flame cutting or shearing, a reasonable margin is required to enable sufficient material to be removed from the cut edges during final machining.
- (4) The preparation of test specimens is to be done in such a manner that test specimens are not subjected to any significant cold working or heating.
- (5) If any test specimen shows defective machining or defects having no relation to the substantial nature, it may be discarded and substituted by another test specimen.

### 202. Form and dimension of test specimen

#### 1. Tensile test specimen

- (1) Tensile test specimens are classified as standard test specimen and proportional test specimen as shown in **Table 2.1.1** depend on the shape and dimension of test specimen.

**Table 2.1.1** Kinds of tensile test specimen

Kind	Flat	Round	Pipe
Proportional	<i>R14B</i>	<i>R14A</i>	<i>R14B, R14C</i>
Standard	<i>R1A, R1B, R5, R13B</i>	<i>R4, R8C, R10</i>	–

- (2) Tensile test specimens are to be of the forms and sizes given in **Fig 2.1.1**. **【See Guidance】**
- (3) The gauge length may be rounded off the nearest 5 mm, provided that the difference between this length and  $L$  is less than 10 % of  $L$ .

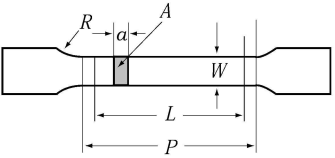
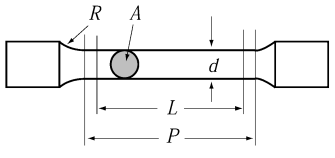
Shapes	Kind	Type	Forms of specimen <sup>(1)</sup>	Size of specimen <sup>(2)</sup>	Materials to be applied
Flat <sup>(3)</sup>	Proportional	<i>R14B</i>		$a = t$ $W = 25 \text{ mm}$ $L = 5.65\sqrt{A}^{(4)}$ $P \cong L + 2\sqrt{A}$ $R = 25 \text{ mm}$	Rolled steels 3 mm thick or more
		<i>R1A</i>		$a = t$ $W = 40 \text{ mm}$ $L = 200 \text{ mm}$ $P \cong 220 \text{ mm}$ $R = 25 \text{ mm}$	Rolled steel plates for boiler, Rolled steel plates for pressure vessel
	Standard	<i>R1B</i>		$a = t$ $W = 25 \text{ mm}$ $L = 200 \text{ mm}$ $P \cong 212.5 \text{ mm}$ $R = 25 \text{ mm}$	Rolled steels 3 mm thick or more,
		<i>R5</i>		$a = t$ $W = 25 \text{ mm}$ $L = 50 \text{ mm}$ $P \cong 60 \text{ mm}$ $R = 15 \text{ mm}$	Rolled steel plates for pressure vessel, Aluminium alloy 12.5mm thick or less
		<i>R13B</i>		$a = t$ $W = 12.5 \text{ mm}$ $L = 50 \text{ mm}$ $P \cong 60 \text{ mm}$ $R = 25 \text{ mm}$	Rolled steels less than 3 mm thick, Aluminium alloy 12.5mm thick or less
Round	Proportional	<i>R14A</i>		$L = 5d^{(5)}$ $P \cong L + 0.5d$ $R = 10 \text{ mm}^{(6)}$	Rolled steels, Castings, Forgings, Spheroidal or nodular graphite iron castings, Copper alloy Aluminium alloy 12.5mm thick or more
		Standard		<i>R4</i>	$d = 14 \text{ mm}$ $L = 50 \text{ mm}$ $P \cong 60 \text{ mm}$ $R = 15 \text{ mm}$
	<i>R10</i>			$d = 12.5 \text{ mm}$ $L = 50 \text{ mm}$ $P \cong 60 \text{ mm}$ $R = 15 \text{ mm}$	Rolled steel plates for boiler, Aluminium alloy 12.5mm thick or less
	<i>R8C</i>			$d = 20 \text{ mm}$ $R = 25 \text{ mm}$	Grey iron castings

Fig 2.1.1 Types and forms of tensile test specimens (unit : mm) (2022)

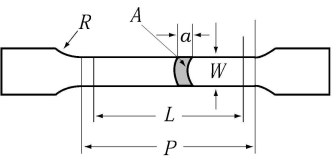
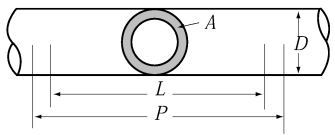
Shapes	Kind	Type	Forms of specimen	Size of specimen	Materials to be applied
Pipe	Proportional	R 14B		$a = t$ $W \geq 12 \text{ mm}$ $L = 5.65\sqrt{A}$ $P \cong L + 2W$ $R = 25 \text{ mm}$	Steel tubes, copper and copper alloy pipes and tubes
		R 14C		$L = 5.65\sqrt{A}$ $P \cong L + 0.5D$ $P$ is the distance between the grips	
NOTES: (1) The notations used are defined as follows. $d$ : Diameter, $A$ : Cross section, $a$ : Thickness, $R$ : Transition radius, $W$ : Width $D$ : External tube diameter, $L$ : Gauge length, $t$ : Plate thickness, $P$ : Parallel test length (2) The both ends of the test specimens may be machined to such shapes as to fit the holder of the testing machine. (3) When the capacity of the available testing machine is insufficient to allow the use of test specimen of full thickness, this may be reduced by machining one of the rolled surfaces. (4) Gauge length $L$ should preferably be greater than 20 mm. (5) $d \geq 10 \text{ mm}$ to 20 mm, preferably 14 mm (6) For nodular cast iron and materials with a specified elongation less than 10%, $R \geq 1,5$					

Fig 2.1.1 Types and forms of tensile test specimens (unit : mm) (2022) (Cont'd)

- (4) The manufacturers may use the test specimens approved by the Society, besides those specified in (2). In this case, the elongation measured at the tensile tests is to be corrected by the following formula **[See Guidance]**:

$$n = a \cdot E \cdot \left( \frac{\sqrt{A}}{L} \right)^b$$

where:

$E$  = equivalent elongation for the proportional test specimens specified in (1) (%).

$n$  = actual measured elongation of test specimen (%).

$A$  = actual cross-sectional area of test specimen ( $\text{mm}^2$ ).

$L$  = actual gauge length of test specimen (mm).

$a, b$  = constants given in below in accordance with the kind of materials.

Material \ Constant	$a$	$b$
Material 1	2.0	0.40
Material 2	2.6	0.55

NOTES:

- Material 1 : For carbon and low alloy steels with a tensile strength not exceeding  $590 \text{ N/mm}^2$  in the hot rolled, annealed, normalized or normalized and tempered conditions.
- Material 2 : For carbon and low alloy steels in the quenched and tempered condition.
- The values of  $a$  and  $b$  for other kinds of materials than Material 1 and Material 2 are to be as deemed appropriate by the Society.

(5) The machine-finished parallel part of test specimens is to be uniform throughout the entire length and the permissible variation (difference between the maximum and minimum values) is to be as specified in **Table 2.1.2**.

**Table 2.1.2 Permissible Variation**

(unit : mm)

Round specimen		Flat specimen with thickness equal to or greater than 6 mm				Flat specimen with thickness less than 6 mm			
Nominal diameter (d)	Permissible variation	Nominal Thickness (t)	permissible variation	Nominal width (w)	permissible variation	Nominal Thickness (t)	permissible variation	Nominal width (w)	permissible variation
$10 \leq d < 12$	0.025	$6 \leq t < 12$	0.02	$25 \leq w < 40$	0.05	$0.6 \leq t < 1.2$	0.002	$12.5 \leq w < 25$	0.02
$12 \leq d < 16$	0.03	$12 \leq t < 20$	0.04	$40 \leq w$	0.10	$1.2 \leq t < 2.5$	0.004	$25 \leq w$	0.04
$16 \leq d$	0.04	$20 \leq t$	0.05			$2.5 \leq t < 6$	0.01		

## 2. Bend test specimen

Bend test specimens are to be of size and dimensions given in **Fig 2.1.2** according to the kind of materials.

Kinds	Size of specimens	Dimensions	Materials to be applied
R 1		$a = 20$ $W = 25$ $r = 1-2$	Headers( <b>Ch 4, 405</b> )
		$a = t$ $W = 30$ $r = 1-2$ Where the thickness of materials exceeds 25mm, the thickness of test specimen may be reduced to 25mm with its surface machined on compression side only.	Rolled steels(Steel plate) ( <b>Ch 3</b> )
R 2		$a = d$ Where the diameter or the width across flat of materials exceeds 35mm, they may be machined finished to a circular section of diameter not less than 35mm.	Rolled steels (Rolled steel bars for boiler) ( <b>Ch 3, 307.</b> )
NOTES: The following designations are used: $a$ : Thickness, diameter or width $d$ : Diameter or width $r$ : Edge radius $W$ : Width $D$ : Diameter of mandrel $t$ : Thickness of material			

**Fig 2.1.2 Size and Dimensions of Bend Test Specimens** (Unit : mm)

## 3. Impact test specimen

(1) Impact test specimens are to be provided in a set of three specimens, and the test specimens are to be machine finished to the forms and dimensions given in **Fig 2.1.3** and **Table 2.1.3** un-

- less the section thickness of the product is less than 12 mm
- (2) The notch is to be cut in a face of the test specimen which was originally perpendicular to the rolled surface, casting surface and forging surface according to the kind of materials. The position of the notch is not to be nearer than 25 mm to a flame cut or sheared edge.

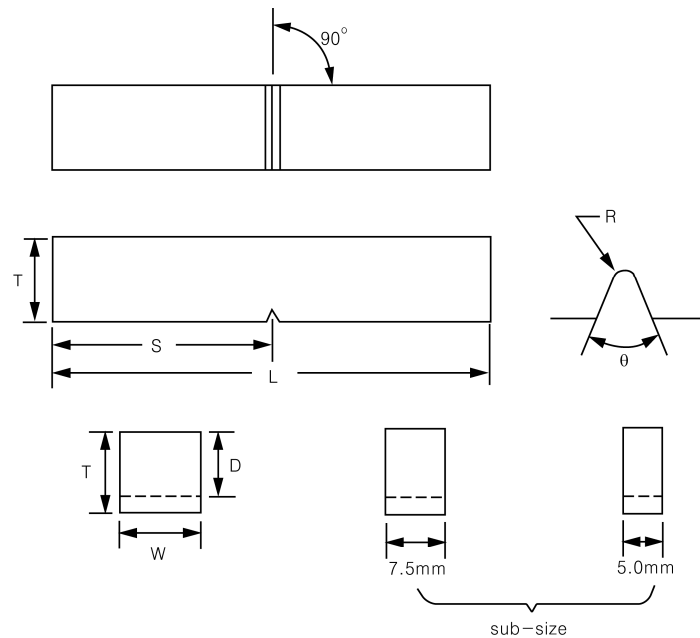


Fig 2.1.3 Impact test specimen

Table 2.1.3 Dimensions of impact Test Specimens

Dimensions	Kinds	Charpy V-notch test specimen
Length (mm)	<i>L</i>	55 ± 0.6
Width (mm)	<i>W</i>	10 ± 0.11
Thickness (mm)	<i>T</i>	10 ± 0.06
Angle of notch (mm)	$\theta$	45 ± 2
Depth below notch (mm)	<i>D</i>	8 ± 0.06
Root radius of notch (mm)	<i>R</i>	0.25 ± 0.025
Distance of notch from end of test specimen (mm)	<i>S</i>	27.5 ± 0.42
Angle between plane of symmetry of notch and longitudinal axis of test specimen (deg)	-	90 ± 2

- (3) Where the impact test specimens, having the size specified in (1) above for rolled steels, tubes and pipes cannot be taken, the width *W* may be the sub-size values given in **Table 2.1.4**. In this case, the average absorbed energy of rolled steels, tubes and pipes is not to be less than the value (by counting fractions of 0.05 and over as 0.1 and disregarding the rest) multiplying the absorbed energy by values given in **Table 2.1.4** in accordance with the width of the test specimens. **[See Guidance]**

**Table 2.1.4 Multiplier to Absorbed Energy**

Thickness and width of sub-size specimen t×W (mm)	Multiplier for absorbed energy
	Average absorbed energy of 3 test specimens
10 × 5 ± 0.06	2/3
10 × 7.5 ± 0.11	5/6

- (4) Where the thickness of a test specimen is less than 6 mm, and where impact test specimen having the sub-size specified in **Table 2.1.4** cannot be taken in welded parts of tubes and pipes, the impact test may be omitted.
- (5) In all cases, the largest size Charpy specimens possible for the material thickness shall be machined. **[See Guidance]**

#### 4. Confirmation for test specimen

The size and dimensions of test specimens are to be carefully inspected and verified by suitable means before testing.

### 203. Testing procedure **[See Guidance]**

#### 1. Tensile test

- (1) When well-defined yield phenomena exists, the value of yield strength(yield stress) is to be measured at the first peak obtained during yielding. When no well defined yield phenomenon exists, the 0.2 % proof stress ( $R_{p0.2}$ ) is to be determined. For austenitic and duplex stainless steel products, the 1 % proof stress ( $R_{p1}$ ) may be determined in addition to  $R_{p0.2}$  as approved by the Society.
- (2) Where the value of yield point or yield stress is measured at tensile test, the rate of loading shall be as following.

Modulus of Elasticity of the material ( $E$ ) (N/mm <sup>2</sup> )	Rate of stressing (N/mm <sup>2</sup> /sec)	
	Min.	Max.
< 150,000	2	20
≥ 150,000	6	60

- (3) After reaching the yield or proof load, for ductile material the machine speed during the tensile test is not to exceed that corresponding to a strain rate of 0.008s<sup>-1</sup>. For brittle materials, such as cast iron, the elastic stress rate is not to exceed 10N/mm<sup>2</sup> per second.

#### 2. Impact test

The impact test is to be conducted on a Charpy impact testing machine having a capacity not less than 150 J and a striking velocity between 4.5 and 6 m/sec, with the test specimens at temperature controlled within ±2°C of the specified temperature.



## Section 3 Rolled Steels

### 301. Rolled steels for hull structural

#### 1. Application

- (1) The requirements are to apply to hull structural rolled steels (hereinafter referred to as "steels") not exceeding 100 mm in thickness.
- (2) These requirements also apply to normal and higher strength Corrosion Resistant Steels with all grades up to 50 mm in thickness for steel plates, wide flats, sections and bars when such steel is used as the alternative means of corrosion protection for cargo oil tanks as specified in the performance standard MSC.289 (87) of Regulation 3-11, Part A-1, Chapter II-1 of the SOLAS Convention (Corrosion protection of cargo oil tanks of crude oil tankers). Normal and higher strength Corrosion Resistant steels as defined within this requirements, are steels whose corrosion resistance performance in the bottom or top of the internal cargo oil tank is tested and approved to satisfy the requirements in MSC.289 (87) in addition to other relevant requirements for hull structural steel, structural strength and construction.
- (3) It is not intended that such steels be used for corrosion resistant applications in other areas of a vessel that are outside of those specified in the performance standard MSC.289 (87) of Regulation 3-11, Part A-1, Chapter II-1 of the SOLAS Convention.
- (4) Any requirement regarding steels over the thickness specified in **Table 2.1.5** is to be left to the discretion of the Society. **【See Guidance】**
- (5) Where improved through thickness properties are specified for plates and wide flats with thickness of 15 mm and over, the tensile test of through thickness property specified in **310**. is to be carried out in addition to the requirements of **301**.
- (6) Brittle crack arrest steels are to be met the additional brittle crack arrest requirements and properties defined in **312**.. (2021)
- (7) Steels other than those specified in **301**. are to be in accordance with the requirements of **101. 2**.

#### 2. Kinds

Steels are classified as specified in **Table 2.1.5**.

**Table 2.1.5 Grades of Rolled Steels for hull**

Kinds		Grade	Thickness <i>t</i> (mm)
Normal strength steel <sup>(1)</sup>	Plates <sup>(3)</sup>	<i>A, B, D, E</i>	$t \leq 100$
	Sections and bars		$t \leq 50$
Higher strength steels <sup>(2)</sup>	Plates <sup>(3)</sup>	<i>AH32, DH32, EH32, FH32</i> <i>AH36, DH36, EH36, FH36</i> <i>AH40, DH40, EH40, FH40</i>	$t \leq 100$
	Sections and bars	<i>AH32, DH32, EH32, FH32</i> <i>AH36, DH36, EH36, FH36</i> <i>AH40, DH40, EH40, FH40</i>	$t \leq 50$
NOTE:			
(1) Provision is made for four grades of normal strength steels based on the impact test requirements.			
(2) For higher strength steels, provision is made for three strength levels(315, 355 and 390 N/mm <sup>2</sup> ) each subdivided into four grades(ex. : <i>AH32, DH32, EH32</i> and <i>FH32</i> ) based on the impact test temperature.			
(3) Steel plates include flat bars not less than 600 mm in width.			

### 3. Manufacturing process

- (1) Unless otherwise approved, the reduction ratio is to be at least 3 to 1. *(2024)*
- (2) The deoxidation practice and chemical composition of each grade are to comply with the requirements given in **Table 2.1.6**. For steel plates and wide flats over 50mm thick and When thermo-mechanical controlled processing (hereinafter referred to as "TMCP") is used as heat treatment, slight deviations in the chemical composition may be allowed as approved by the Society. **【See Guidance】**

### 4. Heat treatment

The heat treatment of each grade is to comply with the requirements given in **Table 2.1.8** and **Table 2.1.9**. **【See Guidance】**

Table 2.1.6 Deoxidation Practice and Chemical Composition (2021)

Kinds	Grade	Thickness, <i>t</i> (mm)	Deoxidation Practice	Chemical Composition (%) <sup>(5)</sup>																									
				<i>C</i>	<i>Si</i>	<i>Mn</i>	<i>P</i>	<i>S</i>	<i>Cu</i>	<i>Cr</i>	<i>Ni</i>	<i>Mo</i>	<i>Al</i> <sup>(8)</sup>	<i>Nb</i>	<i>V</i>	<i>Ti</i>	<i>N</i>												
Normal strength steels	A	<i>t</i> ≤ 50	Killed and Semi-killed <sup>(1)</sup>	0.21 max. (3)(4)	0.50 max.	2.5× <i>C</i> min. (4)	0.035 max.	0.035 max.	-	-	-	-	-	-	-	-	-												
		<i>t</i> > 50	Killed																										
	B	<i>t</i> ≤ 50	Killed and Semi-killed	0.21 max. (4)	0.35 max.	0.8 min. (4)(6)																							
		<i>t</i> > 50	Killed																										
	D	<i>t</i> ≤ 25	Killed	0.21 max. (4)	0.35 max.	0.6 min. (4)																		0.015 min. (2)(9)					
		<i>t</i> > 25	Fine grain treated <sup>(2)</sup>																					0.015 min. (9)					
E	<i>t</i> ≤ 100	Killed and Fine grain treated	0.18 max. (4)	0.35 max.	0.7 min. (4)																								
Higher strength steels <sup>(13)</sup>	AH32	<i>t</i> ≤ 100	Killed and Fine grain treated	0.18 max.	0.50 max.	0.90~ 1.60 (7)	0.035 max.	0.035 max.	0.35 max.	0.20 max.	0.40 max.	0.08 max.	0.015 min. (10)	0.02~ 0.05 (10)(11)	0.05~ 0.10 (10)(11)	0.02 max. (11)	-	-											
	DH32																												
	EH32																												
	AH36																												
	DH36																												
	EH36																												
	AH40	<i>t</i> ≤ 100		0.16 max.	0.90~ 1.60	0.025 max.	0.025 max.	0.80 max.	0.009 max. (12)																				
	DH40																												
	EH40																												
	FH32																												
	FH36																												
FH40																													

NOTES:

- (1) For sections up to 12.5 mm in thickness inclusive, subject to a special approval by the Society, rimmed steel may be accepted.
- (2) For steels above 25 mm in thickness, aluminium treatment is to be used as a fully killed, fine grain practice. However, killed steel up to 50 mm in thickness may be accepted at the discretion of the Society.
- (3) For steel sections, maximum carbon content may be increased to 0.23 %.
- (4) The value of C + Mn/6 is not to exceed 0.40 %.
- (5) Where additions of any other element have been made as part of the steelmaking practice, the content is to be indicated on the test certificate.
- (6) When an impact test as killed steels is conducted, the minimum manganese content may be reduced to 0.60 %.
- (7) For steels up to 12.5 mm in thickness inclusive, the minimum manganese content may be reduced to 0.70 %.
- (8) Aluminium content is to be represented by the acid soluble aluminium content, but may be determined by the total aluminium content. In such a case, the total aluminium content is not to be less than 0.020 %.
- (9) Upon the approval by the Society, grain refining elements other than aluminium may be used.
- (10) The steel is to contain aluminium, niobium, vanadium or other suitable grain refining elements, either singly or in any combination. When used singly, the steel is to contain the specified minimum content of the grain refining element. When used in combination, the specified minimum content of each element is not applicable.
- (11) The total niobium, vanadium and titanium content is to be less than 0.12 %.
- (12) If Aluminium is present, the maximum content of nitrogen may be increased to 0.012 %.
- (13) For TMCP steels, carbon equivalent values(Ceq) and/or cold cracking susceptibility(Pcm) of each steel is to be left to the discretion of the Society. **[See Guidance]**

Table 2.1.7 Mechanical Properties (2021)

Grade	Tensile test			Impact test						
	Yield strength (N/mm <sup>2</sup> )	Tensile strength (N/mm <sup>2</sup> )	Elongation <sup>(6)</sup> ( $L = 5.65\sqrt{A}$ ) (%)	test temp (°C)	Average absorbed energy <sup>(1)</sup> (J)					
					Thickness, <i>t</i> (mm)					
					$t \leq 50$		$50 < t \leq 70$		$70 < t \leq 100$	
$L^{(2)}$	$T^{(2)}$	$L^{(2)}$	$T^{(2)}$	$L^{(2)}$	$T^{(2)}$					
A	235 min.	400~520 <sup>(3)</sup>	22 min.	+20	-	-	(4)	(4)	(4)	(4)
B				0 <sup>(5)</sup>						
D				-20	27 min.	20 min.	34 min.	24 min.	41 min.	27 min.
E				-40						
AH32	315 min.	440~570	22 min.	0	31 min.	22 min.	38 min.	26 min.	46 min.	31 min.
DH32				-20						
EH32				-40						
FH32				-60						
AH36	355 min.	490~630	21 min.	0	34 min.	24 min.	41 min.	27 min.	50 min.	34 min.
DH36				-20						
EH36				-40						
FH36				-60						
AH40	390 min.	510~660	20 min.	0	39 min.	26 min.	46 min.	31 min.	55 min.	37 min.
DH40				-20						
EH40				-40						
FH40				-60						

NOTE:

- (1) When the absorbed energy of two or more test specimens among a set of test specimens is less in value than the specified average absorbed energy or when the absorbed energy of a single test specimen is less in value than 70 % of the specified average absorbed energy, the test is considered to be failed.
- (2) L (or T) denotes that the longitudinal axis of the test specimen is arranged parallel (or transverse) to the final direction of rolling.
- (3) For all thickness of Grade A section, the upper limit of the specified tensile strength, may be exceeded.
- (4) For Grade A steel over 50 mm in thickness with *ARS* or *CRS* heat treatment, impact tests are required. In this case, the average absorbed energy is to comply with the requirements of Grade B steel.
- (5) For Grade B steels up to 25 mm in thickness, generally no impact testing is required.
- (6) The minimum elongation for R1B test specimen ( $L=200\text{mm}$ ) is to be in compliance with the requirement given in the Table below.

Grade	Thickness <i>t</i> (mm)							
	$3 \leq t \leq 5$	$5 < t \leq 10$	$10 < t \leq 15$	$15 < t \leq 20$	$20 < t \leq 25$	$25 < t \leq 30$	$30 < t \leq 40$	$40 < t \leq 50$
A, B, D, E, AH32, DH32, EH32, FH32	14	16	17	18	19	20	21	22
AH36, DH36, EH36, FH36	13	15	16	17	18	19	20	21
AH40, DH40, EH40, FH40	12	14	15	16	17	18	19	20

Table 2.1.8 Heat Treatment and Size of lot for Impact Test specimen for Normal Strength Steels

Grade	Deoxidation practice	Products <sup>(5)</sup>	Heat treatment and Size of Lot for Impact Test Specimen <sup>(1)(2)(3)(4)</sup>					
			Thickness(mm)					
			0	12.5	25	35	50	100
A	Rimmed <sup>(6)</sup>	Sections	AR(-)					
	Semi-killed	All	AR(-)					
	Killed	Plates	AR(-)					N(-) TMCP(-) CRS(50) <sup>(6)</sup> ARS(50) <sup>(6)</sup>
		Sections and bars	AR(-)					
B	Semi-killed	All						
	Killed	Plates	AR(-)	AR(50)			N(50) TMCP(50) CRS(25) ARS(25)	
		Sections and bars						
D	Killed	All	AR(50)	TMCP(50) N(50) CR(50)				
	Fine grain treated	Plates	AR(50)	TMCP(50) N(50) CR(50)			TMCP(50) N(50) CRS(25)	
		Sections and bars		TMCP(50) N(50) CR(50) ARS(50)				
E	Killed and Fine grain treated	Plates	TMCP(P) N(P)					
		Sections and bars	TMCP(50) N(50) CRS(50) ARS(50)					

NOTES:

- (1) Indication symbols used in heat treatment are as follows(the same holds henceforth in this Section):  
*AR* : As Rolled      *CR* : Controlled Rolling Condition      *N* : Normalized Condition  
*TMCP* : Thermo-Mechanical Controlled Processing  
*ARS* : As Rolled Condition subject to special approval of the Society  
*CRS* : Controlled Rolled Condition subject to special approval of the Society.
- (2) In the Table, "marks" put at the end of each symbol for heat treatment stand for the volume of each lot. For examples, (50), (25) and (15) each indicate that steels not greater than 50, 25 and 15 tonnes in weight (belonging to the same charge in the same manufacturing process) are to be taken as one lot; (P), Piece, indicates that steel material rolled directly from one slab, billet or steel ingot is to be taken as one lot; and (-) indicates that no impact test is required. The term "piece" is understood to mean the rolled product from a single slab, billet or ingot if this is rolled directly into plates, sections or bars.
- (3) *TMCP*, *N* or *CR* may be applied to instead of being left in a state of *AR*. In this case, steels are to be treated equivalent to those left in a state of *AR* with regard to the fundamental unit of lot.
- (4) Steel plates include flat bars not less than 600 mm in width.
- (5) For sections up to 12.5 mm in thickness, subject to a special approval by the Society, rimmed steel may be accepted.
- (6) See Note (4) of Table 2.1.7

Table 2.1.9 Heat Treatment and Size of Lot for Impact Test Specimen for Higher Strength Steels

Grade	Deoxidation practice		Products <sup>(5)</sup>	Heat treatment and Size of Lot for Impact Test Specimen <sup>(1)(2)(3)(4)</sup>						
				Thickness (mm)						
				0	12.5	20	25	35	50	100
AH32 AH36	Nb and/or V <sup>(5)</sup>	Plates	AR<50>	TMCP<50> N<50> CR<50>			TMCP<50> N<50> CR<25>			
		Sections and bars		TMCP<50> N<50> CR<50>			ARS<25>			
	Al alone or with Ti	Plates	AR<50>	ARS<50>		TMCP<50> N<50> CR<50>		TMCP<50> N<50> CR<25>		
		Sections and bars		TMCP<50> N<50> CR<50> ARS<25>						
DH32 DH36	Nb and/or V <sup>(5)</sup>	Plates	AR<50>	TMCP<50> N<50> CR<50>			TMCP<50> N<50> CR<25>			
		Sections and bars		TMCP<50> N<50> CR<50>			ARS<25>			
	Al alone or with Ti	Plates	AR<50>	ARS<25>	TMCP<50> N<50> CR<50>		TMCP<50> N<50> CR<25>			
		Sections and bars		TMCP<50> N<50> CR<50> ARS<25>						
EH32 EH36	Killed and Fine grain treated	Plates	TMCP<P> N<P>							
		Sections and bars	TMCP<25> N<25> CR<15> ARS<15>							
FH32 FH36	Any grain refining treated elements	Plates	TMCP<P> N<P> QT<P>							
		Sections and bars	TMCP<25> N<25> QT<25> ARS<15>							
AH40	Any grain refining treated elements	Plates	AR<50>	TMCP<50> N<50> CR<50>			TMCP<50> N<50> QT<P>			
		Sections and bars	AR<50>	TMCP<50> N<50> CR<50>						
DH40	Any grain refining treated elements	Plates	TMCP<50> N<50> CR<50>						TMCP<50> N<50> QT<P>	
		Sections and bars	TMCP<50> N<50> CR<50>							
EH40	Any grain refining treated elements	Plates	TMCP<P> N<P> QT<P>							
		Sections and bars	TMCP<25> N<25> QT<25>							
FH40	Any grain refining treated elements	Plates	TMCP<P> N<P> QT<P>							
		Sections and bars	TMCP<25> N<25> QT<25>							

NOTES:

- (1) Indication symbols used in heat treatment are as follows (the same holds henceforth in this Section);  
**【See Guidance】**  
 AR : As rolled      CR : Controlled Rolling Condition      N : Normalized Condition  
 TMCP : Thermo-Mechanical Controlled Processing      QT : Quenched and Tempered Condition  
 ARS : As Rolled Condition subject to special approval of the Society  
 CRS : Controlled Rolled Condition subject to special approval of the Society.
- (2) In the Table, "marks" put at the end of each symbol for heat treatment stand for the volume of each lot. For examples, <50>, <25> and <15> each indicate that steels not greater than 50, 25 and 15 tonnes in weight (belonging to the same charge in the same manufacturing process) are to be taken as one lot; <P>, Piece, indicates that steel material rolled directly from one slab, billet or steel ingot is to be taken as one lot; and <-> indicates that no impact test is required. The term "piece" is understood to mean the rolled product from a single slab, billet or ingot if this is rolled directly into plates, sections or bars.
- (3) TMCP, N or CR may be applied to instead of being left in a state of AR. In this case, steels are to be treated equivalent to those left in a state of AR with regard to the fundamental unit of lot.
- (4) Steel plates include flat bars not less than 600 mm in width.
- (5) Niobium treatment stands for the addition of Nb either singly or in any combination, regardless of the Nb content, for grain refining. (Refer to Note (10) of Table 2.1.6)

## 5. Mechanical properties

The mechanical properties of steels are to comply with the requirements given in **Table 2.1.7**.

## 6. Selection of test samples

- (1) All material in a batch presented for acceptance tests is to be of the same product form e.g. plates, flats, sections, etc. from the same cast and in the same condition of supply. The test samples are to be fully representative of the material and, where appropriate, are not to be cut from the material until heat treatment has been completed.
- (2) For the samples of steel from which tensile test specimens are cut, except where specially approved by the Society, steels not greater than 50 tonnes in mass (where the amount of scatter is to be less than 10 mm in thickness or diameter even when they belong to the same cast in the same manufacturing process) are to be treated as one lot, and the largest one in thickness or diameter is to be selected from each lot.
- (3) For the samples of steel from which impact test specimens are cut, unless otherwise specially provided or except where specially approved by the Society, the thickest test sample is to be selected from each lot specified in **Table 2.1.8** and **Table 2.1.9**, according to the substance of deoxidation practices, type of products and kind of heat treatments. **[See Guidance]**
- (4) The test samples are to be taken from the following portions according to the requirements (a) to (c) below and Fig 2.1.4, unless otherwise specified:
  - (a) *Plates and flat bars wider than 600mm* :  
One end at a portion approximately 1/4 of the width from the flange end of the plates or flat bars.
  - (b) *Sections and flat bars not exceeding 600mm in width:*  
One end at a portion approximately 1/3 of the width from the flange end. In case of channels, bulb plates and H-section, the test samples may be taken from the portion approximately 1/4 of the depth from the centre line of the web.
  - (c) *Bars:*  
The test samples are to be taken so that the axis of each test specimen may lie as near as possible to the portion specified in (i) and (ii) below. This rule, however, does not apply when, because dimensions of cross section are insufficient for standard test specimens, a piece cut in a proper length from the product having the largest diameter of a certain lot is used as it is for a tensile test.
    - (i) For non-circular sections, at approximately 1/6 of the largest distance from the outside.
    - (ii) For circular section, at approximately 1/6 of the diameter from the outside.

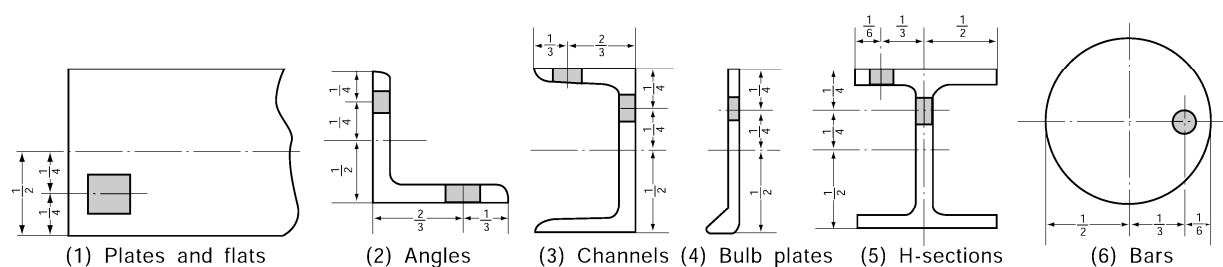


Fig 2.1.4 Selection of Test Samples

## 7. Selection of test specimens

- (1) Test specimens are not to be heat treated separately from the product.
- (2) Tensile test specimens are to be taken according to (a) to (c) below.
  - (a) One test specimen is to be taken from one test sample.
  - (b) The test specimens are to be taken with their longitudinal axis normal to the final direction of rolling. For sections, bars and flat bars not exceeding 600 mm in width or when specially approved by the Society, however, they are to be taken with their longitudinal axis parallel to the final direction of rolling.

- (c) Flat test specimens of full product thickness are, generally, to be used. Round test specimen may be used when the plates and shapes(except bars) thickness exceeds 40 mm or for bars. When tensile test specimens of bar type are taken from plates and shapes except bars, they are to be taken at a portion approximately 1/4 of the thickness from the surface.
- (3) Impact test specimens are to be taken according to (a) to (c) below.
  - (a) A set of test specimens is to be taken from one test sample.
  - (b) The test specimens are to be taken with their longitudinal axis parallel (L direction) to the final direction of rolling. When deemed necessary by the Society, however, they are to be taken with their longitudinal axis normal (T direction) to the final direction of rolling.
  - (c) When the product thickness does not exceed 40 mm, the test specimens are to be cut with their edge within 2 mm from the "as rolled" surface. When the product thickness exceeds 40 mm, the test specimen is to be taken at a portion where the axis of the test specimen corresponds to approximately 1/4 of the thickness (1/6 of the diameter of bars) from the surface.

## 8. Verification of dimensions and thickness [See Guidance]

### (1) Scope

- (a) The Requirements apply to the tolerance on thickness of steel plates and wide flats with widths of 600 mm or greater with thicknesses of 5 mm and over. The thickness tolerances for products below 5 mm are to be in accordance with a national or international standard, e.g. Class B of *ISO 7452:2013*. However, the minus tolerance is to be not exceed 0.3 mm. The wide flats with under 600 mm of width may be agreed between the manufacturer and purchaser at the time of ordering. (2019) (2023)
- (b) Where Class C of **ISO 7452:2013** or equivalent according to national or international standards is applied in lieu of (a) above, the requirements in (4) and (5) below may not be applied. (2019)
- (c) Tolerances for length, width and flatness should be in accordance with a recognized national or international standard which specially agreed by the Society.
- (d) Tolerances for rolled steel other than plates and wide flats may be specially agreed.

### (2) Responsibility

- (a) The responsibility for verification and maintenance of the steel plates within the required tolerances rests with the manufacturer. The Surveyor may require to witness some measurements.
- (b) The responsibility for storage and maintenance of the delivered steel plates with acceptable level of surface conditions rests with the fabricator before the steel plates are used in fabrication. (2019)

### (3) Thickness tolerances

- (a) The tolerances on thickness of a given steel plates are defined as:
  - (i) Minus tolerance is the lower limit of the acceptable range below the nominal thickness.
  - (ii) Plus tolerance is the upper limit of the acceptable range above the nominal thickness.
  - (iii) Nominal thickness is defined by the purchaser at the time of enquiry and order.
- (b) The minus tolerance on nominal thickness of products is 0.3 mm irrespective of nominal thickness. (2019)
- (c) The plus tolerances on nominal thickness are to be in accordance with a recognized national or international standard unless required otherwise by the Society or purchaser. (2019)
- (d) The tolerances on nominal thickness are not applicable to areas repaired by grinding. For areas repaired by grinding the requirements in **301. 9. (2)** of the Rules are to be applied, unless stricter requirements as per a recognized standard are considered by the Society or purchaser. (2019)

### (4) Average thickness

- (a) The average thickness of steel plates or piece is defined as the arithmetic mean of the measurements made in accordance with the requirements in (5) below.
- (b) The average thickness of steel plates or piece is not to be less than the nominal thickness.

### (5) Thickness measurements

- (a) At least two lines among Line 1, Line 2 or Line 3 as shown in **Fig 2.1.4-1**, are to be selected for the thickness measurements and at least three points on each selected line as shown in **Fig 2.1.4-1** are to be selected for thickness measurement. Automated method or manual method is applied to the thickness measurements.
- (b) For automated methods, the measuring points at sides are to be located not less than 10



mm but not greater than 300 mm from the transverse or longitudinal edges of the steel plates. For manual methods, the measuring points at sides are to be located not less than 10 mm but not greater than 100 mm from the transverse or longitudinal edges of the steel plate.

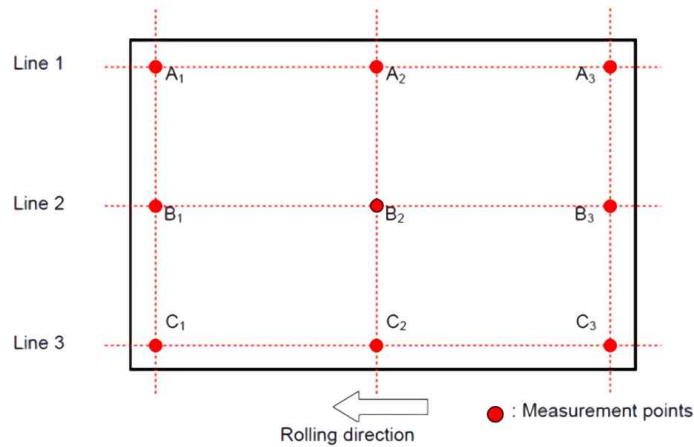


Fig 2.1.4-1 Locations of Thickness Measuring Points

- (c) If more than three points are taken on each line the number of points shall be equal on each line.
- (d) Where the plate is to be later cut by the manufacturer as shown in Fig 2.1.4-2, the measurement locations to be same as the requirements in (a) thru (c) above.

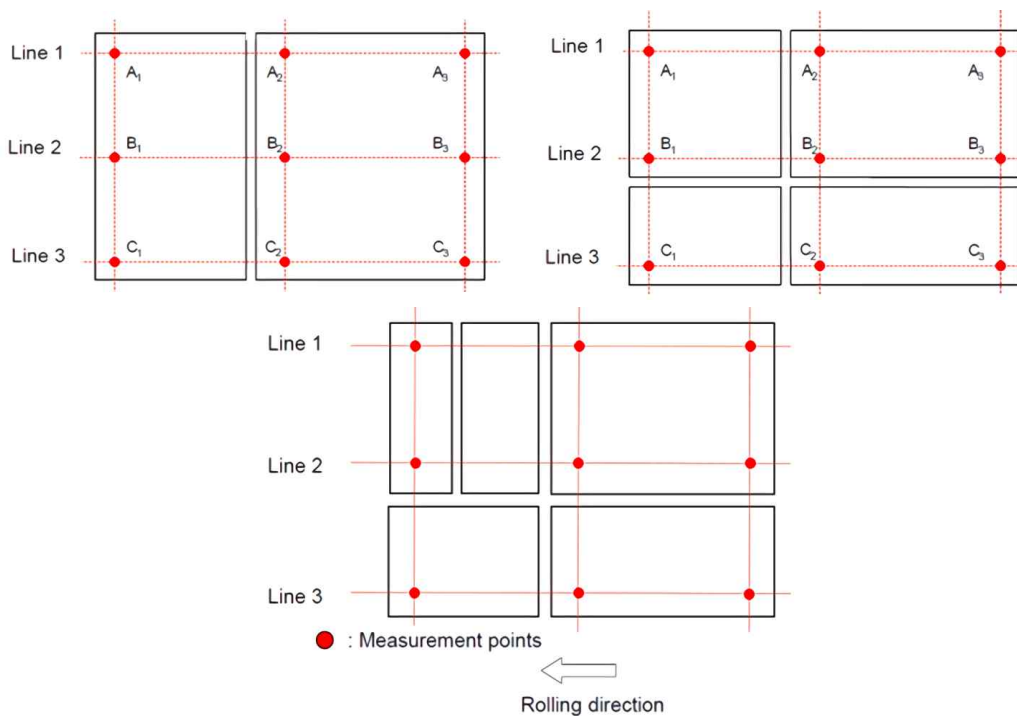


Fig 2.1.4-2 Locations of Thickness Measuring Points for Cut Steel Plates

- (e) The procedure and the records of measurements are to be made available to the Surveyor and copies provided on request.

## 9. Quality and repair of defects (2018)

- (1) The quality of finished steel is to be in accordance with the requirements specified in **108. 1, 2** and as follows.
  - (A) The steel is to be free from surface defects prejudicial to the use of the material for the intended application. The finished material is to have a surface quality in accordance with a recognized standard such as *EN 10163* parts 1, 2 and 3, or an equivalent standard accepted by the Society, unless otherwise specified in **9**.
  - (B) The responsibility for meeting the surface finish requirements rests with the manufacturer of the material, who is to take the necessary manufacturing precautions and is to inspect the products prior to delivery. At that stage, however, rolling or heat treatment scale may conceal surface discontinuities and defects. If, during the subsequent descaling or working operations, the material is found to be defective, the Society may require materials to be repaired or rejected.
  - (C) The surface quality inspection method is to be in accordance with recognized national or international standards agreed between purchaser and manufacturer, accepted by the Society.
  - (D) If agreed by the manufacturer and purchaser, steel may be ordered with improved surface finish over and above these requirements.
  - (E) Acceptance criteria for surface quality
    - (a) Imperfections  
Imperfections of a harmless nature, for example pitting, rolled-in scale, indentations, roll marks, scratches and grooves, regarded as being inherent of the manufacturing process, are permissible irrespective of their number, provided the maximum permissible limits of Class A of *EN 10163-2* or limits specified in a recognized equivalent standard accepted by the Society, are not exceeded and the remaining plate or wide flat thickness remains within the average allowable minus thickness tolerance specified in **8**. Total affected area with imperfection not exceeding the specified limits are not to exceed 15 % of the total surface in question.
    - (b) Defects  
Affected areas with imperfections with a depth exceeding the limits of Class A of *EN 10163-2* or the maximum permissible limits specified in a recognized equivalent standard accepted by the Society, are to be repaired irrespective of their number. Cracks, injurious surface flaws, shells (over lapping material with non-metallic inclusion), sand patches, laminations and sharp edged seams (elongated defects) visually evident on surface and/or edge of plate are considered defects, which would impair the end use of the product and which require rejection or repair, irrespective of their size and number.
- (2) Repair for surface defects
  - (A) Grinding repair  
The surface defects may be removed by local grinding, and be as follows:
    - (a) The nominal product thickness will not be reduced by more than 7 % or 3 mm, whichever is the less.
    - (b) Each single ground area does not exceed 0.25 m<sup>2</sup> and all ground areas do not exceed 2 % of the total surface in question.
    - (c) Ground areas lying in a distance less than their average breadth to each other are to be regarded as one single area.
    - (d) Ground areas lying opposite each other on both surfaces must not decrease the product thickness by values exceeding the limits as stated above (i).
    - (e) Complete elimination of the defects may be performed by a magnetic particle or dye penetrant test procedure at the Manufacturer's discretion. (2020)
    - (f) Defects or unacceptable imperfections are to be completely removed by grinding and the remaining plate or wide flat thickness are to be remained within the average allowable minus thickness tolerance specified in **8**. The ground areas are to be a smooth transition to the surrounding surface of the product.
  - (B) Welding repair  
Local defects which cannot be repaired by grinding as stated above (a) may be repaired with the Surveyor's consent by chipping and/or grinding followed by welding subject to the following conditions. Repair of defects such as unacceptable imperfections, cracks, shells or seams is to be followed by magnetic particle or liquid penetrant testing.
    - (a) Any single welded area is not to be exceeded 0.125 m<sup>2</sup> and the sum of all areas is not

- to be exceeded 2 % of the surface side in question. The distance between two welded areas shall not be less than their average width.
- (b) The weld preparation must not reduce the thickness of the product below 80 % of the nominal thickness. For occasional defects with depths exceeding the 80% limit, special consideration at the Surveyor's discretion will be necessary.
  - (c) If weld repair depth exceeds 3 mm, UT may be requested by the Society. If required, UT is to be carried out in accordance with an approved procedure.
  - (d) The repair is to be carried out by qualified welders using an approved procedure for the appropriate steel grade. The electrodes are to be of low hydrogen type and are to be dried in accordance with the manufacturer's requirements and protected against re-humidification before and during welding.
- (C) Shapes may be conditioned by the manufacturer for the removal of surface defects in accordance with the following limitations.
- (a) For material less than 9.5 mm thickness, in which the defects are not more than 0.8 mm in depth, the defects may be removed by grinding or chipping.
  - (b) For material 9.5 mm and over in thickness, in which the defects are not more than 1.6 mm in depth, the defects may be removed by grinding or chipping.
  - (c) Surface defects which are greater in depth than the limits shown above (a) and (b) may be removed by chipping or grinding and then depositing weld metal, in the presence of the Surveyor, subject to the following conditions.
    - (i) The total area of the chipped or ground surface of any piece is not to exceed 2 % of the total surface area of that piece.
    - (ii) After removal of any defect preparatory to welding, the thickness of the shape is not to be reduced by more than 30 % of the nominal thickness, nor is the depth of depression prior to welding to exceed 12.5 mm in any case.
- (D) Before repair works prescribed in above (B) or (C) (c), the following documents are to be submitted to the Society for approval.
- (a) Specifications of repairing procedure which state about kind of surface defects, the way of chipping, grinding and welding, etc.
  - (b) Reports on results of tensile test, bend test, impact test, macro-structure inspection and hardness test on test samples repaired according to the procedure specified in above (a).
- (3) Internal soundness
- (A) If plates and wide flats are ordered with ultrasonic inspection or required by the Society, the test procedure and acceptance criteria are to be made in accordance with an accepted standard at the discretion of the Society. However, the probe frequency is to be of 4MHz in general. **[See Guidance]**
  - (B) Verification of internal soundness is the responsibility of the manufacturer. The acceptance of internal soundness by the Society's surveyor is to be not absolved the manufacturer from this responsibility. (2018)

## 10. Retest Procedures

- (1) Where the tensile test fails to meet the requirements, two further tensile tests may be made from the same piece. If both of these additional tests meet all of the requirements, the piece and the remaining pieces from the same lot may be accepted.
- (2) If one or both of the additional tests referred to above are unsatisfactory, the piece from which the above-mentioned test pieces have been taken is to be rejected. However, the remaining material from the same lot may be accepted, provided that two of the remaining pieces in the lot, selected in the same way, are tested with satisfactory results.
- (3) (a) Where the result of the impact test is unsatisfactory, additional tests may be carried out, with the exception of the cases specified in (i) and (ii) below, by taking a set of test specimens out of the same piece from which the above-mentioned test specimens have been taken.
  - (i) The absorbed energy of all test specimens is under the required average absorbed energy.
  - (ii) The absorbed energy of two of the test specimens is under 70 % the required average absorbed energy.
- (b) In case of the previous (a), all pieces of the same lot from which the test specimens have been taken, may be accepted, provided that the average absorbed energy of the six test specimens, including those which have been rejected as unsatisfactory, is not less than the

required average absorbed energy, and that not more than two individual results are lower than the required average absorbed energy and of these, not more than one result is below 70 % of the required average absorbed energy.

- (4) When the initial piece, representing a lot, gives unsatisfactory results from the additional Charpy V-notch impact tests referred to the preceding (3), this piece is to be rejected but the remaining material in the lot may be accepted provided that two of the remaining pieces in the lot are tested with satisfactory results. If unsatisfactory results are obtained from either of these two pieces, then the lot of material is to be rejected. The pieces selected for these additional tests are to be the thickest remaining in the batch.
- (5) If any test specimen fails because of faulty preparation, visible defects or (in the case of tensile test) because of fracturing outside the range permitted for the appropriate gauge length, the defective test piece may, at the Surveyors discretion, be disregarded and replayed by an additional test piece of the same type.
- (6) Where the test pieces fail in the retests specified above, the piece from which the test pieces have been taken is to be rejected, However, at the consultation of the manufacturer and the orderer, the remaining pieces in the lot may be resubmitted individually for test and those pieces which give satisfactory results may be accepted.
- (7) At the consultation of the manufacturer and the order, the rejected piece may be resubmitted—after heat treatment of re-heat treatment, or may be resubmitted as any other grade of steel and then, may be accepted, provided that the required tests are satisfactory.

#### 11. Marking

- (1) Steels which have satisfactorily complied with the required tests are to be marked with the identification mark in accordance with the requirements in **110.**
- (2) Materials supplied in the thermo-mechanical controlled processing condition is to have the letters *TM* added after the material grade mark. (e.g. *EH40TM*)
- (3) Steel plates that have complied with the requirements for corrosion resistant steel will be marked with a designation by adding a corrosion designation to the unified identification mark for the grade of steel. And the corrosion resistant steel is to be designated according to its area of application as follows:
  - (a) Lower surface of strength deck and surrounding structures : RCU
  - (b) Upper surface of inner bottom plating and surrounding structures : RCB
  - (c) For both strength deck and inner bottom plating : RCW(e.g. AH32 TM RCU Z35)

#### 12. Forming

The cold deformation limit of hull structural rolled steels is to be in accordance with the Guidance specially specified by the Society. **[See Guidance]**

#### 13. Test certificates (2017)

The Surveyor is to be supplied with the number of copies as required by the Society, of the test certificates for all accepted materials. The Society may require separate documents of each grade of steel. These documents are to contain, in addition to the description, dimensions, etc., of the material, at least the following particulars:

- (1) Purchaser's name or purchaser's order number and if known the hull number for which the material is intended.
- (2) Identification of the cast and rolled piece.
- (3) Identification of the steelworks.
- (4) Material grade mark
- (5) Chemical composition (ladle analysis values of elements controlled by the requirements)
- (6) For steel with a corrosion resistant steel designation the weight percentage of each element added or intentionally controlled for improving corrosion resistance.
- (7) Mechanical properties
- (8) Condition of heat treatment (e.g. normalized or controlled roll except for as rolled)
- (9) Deoxidization procedure is to be stated. (rimmed steel only)
- (10) Through thickness properties of **310.**, where applicable

### 302. Rolled steel plates for boiler

#### 1. Application

- (1) These requirements are to apply to the steel plates (hereinafter referred to as "steel plates") for boilers and pressure vessels to be used at high temperatures.
- (2) Steel plates other than those specified in **302.** are to comply with the requirements in **101. 2.**

#### 2. Kinds The steel plates are classified as specified in **Table 2.1.10.**

**Table 2.1.10 Grades of Steel Plates (2019)**

Grade	Thickness (mm)
<i>RSP24, RSP30</i>	6~200
<i>RSP32</i>	
<i>RSP30A, RSP32A</i>	6~150

#### 3. Heat treatment

- (1) For steel plates of the "*RSP24, RSP30 and RSP32*" grade with 50 mm or less and of the "*RSP30A and RSP32A*" grade with 38 mm or less in thickness, they are to be as rolled. They, however, may be heat treated(normalized or annealed for stress relieving) as deemed necessary by the manufacturer. (2019)
- (2) For steel plates of the "*RSP24, RSP30 and RSP32*" grade more than 50 mm and of the "*RSP30A and RSP32A*" grade more than 38 mm in thickness, they are to be either normalized to obtain the normal grain size or heated uniformly to such a temperature at the time of hot forming that an effect equivalent to normalizing can be achieved. In case of normalizing, it is, in principle, to be performed by the manufacturer. (2019)

#### 4. Chemical composition

The chemical composition of steel plates is to comply with the requirements given in **Table 2.1.11.**

**Table 2.1.11 Chemical Composition (2019)**

Grade	Chemical composition (%)						
	Thickness t (mm)	C	Si	Mn	P	S	Mo
<i>RSP24</i>	$t \leq 25$	0.24 max.	0.15~0.40	0.90 max.	0.030 max.	0.030 max.	-
	$25 < t \leq 50$	0.27 max.					
	$50 < t \leq 200$	0.30 max.					
<i>RSP30</i>	$t \leq 25$	0.28 max.					
	$25 < t \leq 50$	0.31 max.					
	$50 < t \leq 200$	0.33 max.					
<i>RSP32</i>	$t \leq 25$	0.31 max.					
	$25 < t \leq 50$	0.33 max.					
	$50 < t \leq 200$	0.35 max.					
<i>RSP30A</i>	$t \leq 25$	0.18 max.	0.90 max.	0.020 max.	0.020 max.	0.45~0.60	
	$25 < t \leq 50$	0.21 max.					
	$50 < t \leq 100$	0.23 max.					
	$100 < t \leq 150$	0.25 max.					
<i>RSP32A</i>	$t \leq 25$	0.20 max.					
	$25 < t \leq 50$	0.23 max.					
	$50 < t \leq 100$	0.25 max.					
	$100 < t \leq 150$	0.27 max.					

NOTES:  
1. For *RSP30* with 25 mm and over in thickness, carbon and manganese content may be 0.30 % or less and 1.00 % or less, respectively.

## 5. Mechanical properties

The mechanical properties of steel plates are to comply with the requirements given in **Table 2.1.12**.

**Table 2.1.12 Mechanical Properties (2019)**

Grade	Yield strength (N/mm <sup>2</sup> )	Tensile strength (N/mm <sup>2</sup> )	Elongation (%)	
			R1A	R10
RSP24	235 min.	410 ~ 550	21 min.	25 min.
RSP30	295 min.	450 ~ 590	19 min.	23 min.
RSP32	315 min.	480 ~ 620	17 min.	21 min.
RSP30A	295 min.	450 ~ 590	19 min.	23 min.
RSP32A	315 min.	480 ~ 620	17 min.	21 min.

NOTE:

- (1) R1A tensile test specimen is to be used for steel plate up to 50mm in thickness and R10 test specimen for steel plate more than 50 mm in thickness. However R10 test specimen can be used for steel plate more than 40 mm in thickness.
- (2) For material under 8 mm in thickness, a deduction from the specified percentage of elongation of 1 % is to be made for each decrease of 1 mm of the specified thickness.
- (3) For the plates over 90 mm in thickness, the elongation may be reduced from that mentioned in the above Table by 0.5 % for each increment of 12.5 mm or fraction thereof exceeding 90 mm in thickness. Such reduction, however, is limited to 3 %.
- (4) In case where the elongation of RSP30A and RSP32A steel plate with thickness over 6mm and less than 20 mm is insufficient within 3 % of the specified value, It will be able to regard as satisfactory if the elongation of the gauge length 50 mm which includes a rupture part is of 25 % or more.

## 6. Selection and heat treatment of test samples [See Guidance]

- (1) For the steel plates which are not to be heat treated, one test sample is to be taken from each plate as rolled directly from one slab or ingot
- (2) For the steel plates which are to be heat treated, one test sample is to be taken from every similarly heat treated plate as rolled directly from one slab or ingot.
- (3) For steel plates to which stress relieving is required after welding or stress relieving is applied by the purchaser one or several times repeatedly during their working process, instruction of that effect is to be given at the time when they are placed for an order. In case where the procedure of stress relieving is not specified by the purchaser, a heat treatment is to be applied for the test samples by heating them slowly and uniformly to the temperature of 600°C to 650°C, holding at that temperature for a period of over one hour per 25 mm of thickness, and then, to be cooled to 300°C in the furnace before exposure in a still atmosphere.
- (4) The test samples are to be taken from the portion approximately 1/4 of the width from the side end of the plates.

## 7. Selection of test specimens

Tensile test specimens are to be taken according to (1) to (3) below.

- (1) One test specimen is to be taken from one test sample.
- (2) The test specimens are to be taken with their longitudinal axis normal to the final direction of rolling.
- (3) The test specimens of bar type are to be taken from the portion approximately 1/4 of the thickness from the surface.

## 8. Tolerance for thickness

Surface inspection and verification of dimensions are to be in accordance with the requirements in **301. 8**. The minus tolerance for the nominal thickness of plates is to be 0.25 mm.

## 9. Retest procedure

Where the tensile tests from the first test specimens selected fail to meet the requirements, additional tests may be conducted according to the requirements given in **109**.

## 10. Marking

- (1) Steel plates which have satisfactorily complied with the required tests are to be marked with the identification mark relating to heat treatment in addition to the requirements in **110**.

- (2) The marks relating to heat treatment are to be as specified in the following:
- (a) Where the plates are normalized : N (e.g. : RSP 30N) (2019)
  - (b) Where the test specimens are normalized : TN (e.g. : RSP 30TN) (2019)
  - (c) Where the test specimens are heat treated corresponding to the stress relieving to be applied : SR (e.g. : RSP 30N-SR, RSP 30TN-SR) (2019)

### 303. Rolled steel plates for pressure vessel

#### 1. Application

- (1) These requirements are mainly to apply to the steel plates for pressure vessels to be used at atmospheric temperature (hereinafter referred to as "steel plates")
- (2) The steel plates having characteristics differing from those specified in **303.** are to comply with the requirements in **101. 2.**

#### 2. Kinds

The steel plates are classified as specified in **Table 2.1.13.**

**Table 2.1.13 Grades of Steel Plates**

Grade	Thickness (mm)
<i>RPV24</i>	6~200
<i>RPV32, RPV36, RPV42, RPV46, RPV50</i>	6~150

#### 3. Heat treatment

- (1) *RPV24* plate is to be as rolled. The plates, however, may be normalized as deemed necessary by the Society.
- (2) *RPV32* and *RPV36* plates are to be as rolled. The plates, however, may be normalized as deemed necessary by the Society. But, they may be *TMCP* or quenched and tempered under the approval by the Society.
- (3) *RPV42* plate is to be *TMCP*. The plate, however, may be normalized or quenched and tempered under the approval by the Society.
- (4) *RPV46* and *RPV50* plates are to be quenched and tempered. But, they may be *TMCP* under the approval by the Society.

#### 4. Chemical composition

- (1) The chemical composition of steel plates is to comply with the requirements given in **Table 2.1.14.**

**Table 2.1.14 Chemical Composition**

Grade	Chemical composition (%)					Carbon equivalent (%)		
	C		Si	Mn	P	S	$t \leq 50(\text{mm})$	$50 < t \leq 75(\text{mm})$
<i>RPV24</i>	$t \leq 100 \text{ mm}$	0.18 max.	0.35 max.	1.40 max.	0.030 max.	0.030 max.	-	-
	$t > 100 \text{ mm}$	0.20 max.					-	-
<i>RPV32</i>	0.18 max.		0.55 max.	1.60 max.			-	-
<i>RPV36</i>	0.20 max.						-	-
<i>RPV42</i>	0.18 max.		0.75 max.				0.44 max.	0.46 max.
<i>RPV46</i>				0.45 max.			0.47 max.	
<i>RPV50</i>								

NOTE:

- (1) Where deemed necessary, other elements than specified in **Table 2.1.14** may be added. In that case, such elements are to be stated in the test sheets.
- (2) For *RPV46* and *RPV50* steel plates which not to be quenched and tempered, slight deviations in the chemical composition may be allowed as approved by the Society.

(2) Carbon equivalent(Ceq) and weld cold cracking susceptibility(Pcm) value of steel plates are to comply with the requirements given in **Table 2.1.14-1**.

**Table 2.1.14-1 Carbon equivalent(Ceq) and Pcm value**

Grade	Heat treatment	Carbon equivalent (%)					Pcm value (%)			
		$t \leq 50$ (mm)	$50 < t \leq 75$ (mm)	$75 < t \leq 100$ (mm)	$100 < t \leq 125$ (mm)	$125 < t \leq 150$ (mm)	$t \leq 50$ (mm)	$50 < t \leq 75$ (mm)	$75 < t \leq 100$ (mm)	$100 < t \leq 150$ (mm)
<i>RPV32</i>	TMCP <sup>(1)</sup>	0.39 max.	0.41 max.		0.43 max.		0.24 max.	0.26 max.		0.28 max.
<i>RPV36</i>		0.40 max.	0.42 max.		0.44 max.		0.26 max.	0.27 max.		0.29 max.
<i>RPV42</i>		0.43 max.	0.45 max.		-		0.27 max.	0.28 max.	0.29 max.	-
<i>RPV46</i>	Quenching and Tempering <sup>(2)</sup>	0.44 max.	0.46 max.	0.49 max.	0.52 max.	0.54 max.	0.28 max.	0.30 max.		
<i>RPV50</i>		0.45 max.	0.47 max.	0.50 max.	0.53 max.	0.55 max.				
(Note)										
(1) Carbon equivalent and Pcm value of <i>RPV32</i> , <i>RPV36</i> and <i>RPV42</i> plates quenched and tempered are to be as deemed appropriate by the Society. <b>[See Guidance]</b>										
(2) Carbon equivalent and Pcm value of <i>RPV46</i> and <i>RPV50</i> plates, which not to be quenched and tempered, are to be as deemed appropriate by the Society. <b>[See Guidance]</b>										

### 5. Mechanical properties

The mechanical properties of steel plates are to comply with the requirements given in **Table 2.1.15**.

**Table 2.1.15 Mechanical Properties**

Grade	Tensile test							Impact test		
	Yield strength (N/mm <sup>2</sup> )			Tensile strength (N/mm <sup>2</sup> )	Elongation(%)			Test temp. (°C) <sup>(5)</sup>	Average absorbed energy(J)	Absorbed energy of individual test specimen(J)
	Thickness of plate <i>t</i> (mm)				Thickness of plate <i>t</i> (mm)					
	$t \leq 50$	$50 < t \leq 100$	$100 < t \leq 200$		$t \leq 16$ <sup>(2)</sup>	$16 < t \leq 40$ <sup>(2)</sup>	$40 < t$ <sup>(3)</sup>			
<i>RPV24</i>	235 min.	215 min.	195 min.	400~510	17 min.	21 min.	24 min.			
<i>RPV32</i>	315 min.	290 min.	275 min. <sup>(1)</sup>	490~610	16 min.	20 min.	23 min.			
<i>RPV36</i>	355 min.	335 min.	315 min. <sup>(1)</sup>	520~640	14 min.	18 min.	21 min.			
<i>RPV42</i>	410 min.	390 min.	370 min. <sup>(1)</sup>	550~670	12 min.	16 min.	18 min.	-10	47 min.	27 min.
<i>RPV46</i>	450 min.	430 min.	410 min. <sup>(1)</sup>	570~700	19 min. <sup>(4)</sup>	26 min. <sup>(4)</sup>	20 min.			
<i>RPV50</i>	490 min.	470 min.	450 min. <sup>(1)</sup>	610~740	18 min. <sup>(4)</sup>	25 min. <sup>(4)</sup>	19 min.			
NOTE:										
(1) To be applied for the plates 150 mm or less in thickness										
(2) To be tested with <i>R1A</i> test specimen.										
(3) To be tested with <i>R1A</i> test specimen. When the capacity of the available testing machine does not permit testing the full thickness specimen, <i>R4</i> test specimen may be used.										
(4) To be tested with <i>R5</i> test specimen.										
(5) Test temperature of <i>RPV32</i> , <i>RPV36</i> and <i>RPV42</i> plates manufactured by <i>TMCP</i> is to be -20°C.										



## 6. Selection of test samples [See Guidance]

- (1) For the steel plates which are not to be heat treated, one test sample is to be taken from each plate as rolled directly from one slab or ingot.
- (2) For the steel plates which are to be heat treated, one test sample is to be taken from every similarly heat treated plate as rolled directly from one slab or ingot.
- (3) For steel plates to which stress relieving is required after welding or stress relieving is applied by the purchaser, test samples are to be heat treated in accordance with the requirements in **302. 6 (3)**.
- (4) The test samples are to be taken from the portion approximately 1/4 of the width from the side end of the plate.

## 7. Selection of test specimen

- (1) Tensile test specimens are to be taken according to (a) to (c) below.
  - (a) One test specimen is to be taken from one test sample.
  - (b) The test specimens are to be taken with their longitudinal axis normal to the final direction of rolling .
  - (c) The test specimens of bar type are to be taken from the portion approximately 1/4 of the thickness from the surface.
- (2) Impact test specimens is to be taken according to (a) to (c) below. [See Guidance]
  - (a) A set of test specimens are to be taken from one test sample.
  - (b) The test specimens are to be taken with their longitudinal axis parallel (L direction) to the final direction of rolling. Where deemed necessary by the Society, however, they are to be taken with their longitudinal axis normal (T direction) to the final direction of rolling.
  - (c) The test specimens are to be taken at a portion where the axis of the test specimen corresponds to approximately 1/4 of the thickness from the surface.

## 8. Tolerance for thickness

Surface inspection and verification of dimensions are to be in accordance with the requirements in **301. 8**. The minus tolerance for the nominal thickness of plates is to be 0.25 mm.

## 9. Retest procedures

Where the tensile test and impact tests from the first test specimen selected fails to meet the requirements, additional tests may be conducted according to the requirements given in **109**.

## 10. Marking

- (1) Steel plates which have satisfactorily complied with the required tests are to be marked with the identification mark relating to heat treatment in addition to the requirements in **110**.
- (2) The marks relating to heat treatment in (1) are to be as specified in the following:
  - (a) Where the plates are normalized : *N* (e.g. : *RPV 32N*)
  - (b) Where the plates are quenched and tempered : *QT* (e.g. : *RPV 46QT*)
  - (c) Where the plates are heat treated in *TMCP* condition : *TM* (e.g. : *RPV 36TM*)
  - (d) Where only test specimens are normalized in the steel plate as rolled) : *TN* (e.g. : *RPV 32TN*)
  - (e) Where the test specimens are heat treated corresponding to the stress relieving to be applied in the steel plate normalized : *NSR* (e.g. : *RPV 32NSR*)

## 11. Steel plates equivalent to standard

- (1) The mild steel plates of grade *RD* and *RE*, the high tensile steels of rolled steels for hull specified in **301**. are taken as equivalent to the plates specified in **303**. in case where the test specimens are taken as required in **Pars 6** and **7** and test results comply with the requirements in **301**. In this case, "*PV*" is to be suffixed to the markings to indicate the kind of plates specified in **301**.
- (2) Any requirements regarding heat treatment of steel plates specified in (1) is left to the discretion of the Society.

### 304. Rolled steels for low temperature service

#### 1. Application

- (1) The requirements are to apply to the rolled steels not exceeding 50 mm in thickness intended for tanks and ship's hull structures adjacent to tanks of liquefied gas carriers, and other parts such a hull structures of refrigerated cargo carrier which are exposed to low temperature (hereinafter referred to as "steels"). (2023)
- (2) Any requirement regarding the steels over 50 mm in thickness is left to the discretion of the Society. (2023) **【See Guidance】**
- (3) The requirements other than those specified in **304.** are applicable to the requirements in **301.**
- (4) The steels other than those specified in **304.** are to comply with the requirements in **101. 2.**

#### 2. Kinds

Steels are classified as specified in **Table 2.1.16.**

**Table 2.1.16 Grades and Chemical Composition (2017) (2023)**

Kinds	Grade	Deoxidation	Chemical composition (%)															
			C	Si	Mn	P	S	Ni	Cr	Cu	Mo	Al <sup>(3)</sup>	Nb	V	Ti			
Carbon steels	RL 235A	Fully killed Aluminium treated fine grain	0.15	0.10~	0.70~	0.030	0.030	0.8 max.	(1)			0.02 min.	-					
	RL 235B		max.	0.30	1.50	max.	max.											
	RL 325A		0.16	0.10~	0.80~	0.025	0.025											
	RL 325B		max.	0.55	1.60	max.	max.											
	RL 355		0.16	0.10~	0.80~	0.025	0.025											
			max.	0.55	1.60	max.	max.											
Nickel alloy steels	RL 1N355	Killed and fine grain treated	0.18	0.35	0.80~	0.025	0.010	1.30~	(2)			-	-	0.05 max.	-			
	RL 2N255		max.	max.	1.50		max.	0.020					2.10~		0.30	0.40	0.12	0.02 max.
	RL 3N355		0.15			0.020		3.25~	(2)				-					
	RL 5N390		max.				0.005	4.75~									-	
	RL 9N490		0.15	0.35	0.30~		max.	max.					5.25					
			max.	max.	0.80	max.	max.	8.50~										
			0.10				10.00											

**NOTE:**

- (1) These elements may be added, the certificates is to contain these elements.
- (2) The content of Cr+Cu+Mo is not to exceed 0.50%. The content of Mo for RL 9N490 is not to exceed 0.10%
- (3) Aluminium content is to be represented by the total aluminium content, but may be determined by the acid soluble aluminium content. In such a case, the acid soluble aluminium content is not to be less than 0.015%.

### 3. Heat treatment

The heat treatment of steels is to comply with the requirements given in **Table 2.1.17**.

**Table 2.1.17 Heat Treatment (2017) (2023)**

Kinds	grade	Heat treatment
Carbon steels	<i>RL 235A</i>	Normalized or <i>TMCP</i>
	<i>RL 235B</i>	
	<i>RL 325A</i>	Quenched and Tempered or <i>TMCP</i> <sup>(1)</sup>
	<i>RL 325B</i>	
	<i>RL 355</i>	
Nickel alloy steels	<i>RL 1N355</i>	Normalized or Normalized and Tempered or Quenched and Tempered <sup>(2)</sup>
	<i>RL 2N255</i>	Normalized or Normalized and Tempered <sup>(2)</sup>
	<i>RL 3N355</i>	Normalized or Normalized and Tempered or Quenched and Tempered <sup>(2)</sup>
	<i>RL 5N390</i>	
	<i>RL 9N490</i>	Double normalized and tempered or Quenched and Tempered <sup>(2)</sup>
NOTE: (1) Heat treatment may be conducted according to Normalising, subject to the special approval by the Society. (2018) (2) Heat treatment may be conducted according to <i>TMCP</i> , subject to the special approval by the Society.		

### 4. Deoxidation practice and chemical composition

- (1) The deoxidation practice and chemical composition of each grade are to comply with the requirements given in **Table 2.1.16**. When deemed necessary, chemical elements other than those given in the table may be added.
- (2) When heat treatment has been conducted according to *TMCP*, the chemical composition of steels specified in **Table 2.1.16** may be modified subject to the approval by the Society.

### 5. Mechanical properties

- (1) The mechanical properties of steels are to comply with the requirements given in **Table 2.1.18**.
- (2) Where deemed necessary by the Society, other tests on notch toughness may be required additionally.
- (3) In the case of steels in accordance with **Pt 7, Ch 5, Sec 17, 1712**. (Special requirements for ammonia) of the Rules, the specified value of the maximum yield stress or proof stress may be limited after approval by the Society. (2023)

Table 2.1.18 Mechanical properties (2017) (2023)

Kinds	grade	Tensile test					Impact <sup>(5)(6)</sup>			
		Yield strength (N/mm <sup>2</sup> )		Tensile strength (N/mm <sup>2</sup> )	Elongation(%) <sup>(4)</sup> ( $L = 5.65\sqrt{A}$ )			Test temp. <sup>(7)</sup> (°C)	Average absorbed energy(J)	
		Thickness of plate $t$ (mm)			Thickness of plate $t$ (mm)				$L$	$T$
		$6 < t \leq 30$	$30 < t$		$6 < t \leq 16^{(2)}$	$16 < t \leq 40^{(2)}$	$40 < t^{(3)}$			
Carbon steels	<i>RL 235A</i>	235 min. <sup>(1)</sup>		400~510	$L$	$T$	24 min.	41 min.	27 min.	-40
	<i>RL 235B</i>									-50
	<i>RL 325A</i>	325 min.		440~560	22 min.	30 min.	22 min.			-60
	<i>RL 325B</i>									
	<i>RL 355</i>	355 min.		490~610	20 min.	28 min.	20 min.			
Nickel alloy steels	<i>RL 1N355</i>	355 min.	345 min.	490~640	22 min.			-80		
	<i>RL 2N255</i>	255 min.		450~590	21 min.			-70		
	<i>RL 3N355</i>	355 min.	345 min.	490~640	22 min.			-100		
	<i>RL 5N390</i>	390 min.	380 min.	530~710	20 min.			-120		
	<i>RL 9N490</i>	490 min.	480 min.	640~840	18 min.			-196		

NOTES:

- (1) Same or above 215 N/mm<sup>2</sup> when the thickness of plate is above 40 mm.
- (2) Carbon steels are to be tested with *R5* test specimen. To be tested with *R1A* test specimen For *RL 235A* and *RL 235B*.
- (3) Carbon steels are to be tested with *R4* test specimen.
- (4) In the case of carbon steel, the calibrated elongation value according to **ISO 2566-1:2021** may be required by the different specimen type from requirements in this Table.
- (5)  $L$  (or  $T$ ) indicates that the longitudinal axis of the test specimen is arranged parallel (or transverse) to the final direction of rolling.
- (6) When the absorbed energy of two or more test specimens among a set of test specimens is less in value than the specified average absorbed energy or when the absorbed energy of a single test specimen is less in value than 70 % of the specified average absorbed energy, the test is considered to have failed.
- (7) Impact test temperature for steels specified in **Pt 7, Ch 5** is to comply with the requirements given in **Table 2.1.18-1**.

## 6. Selection of test sample

- (1) For steel plates, one test sample is to be taken from each plate as rolled directly from one slab or ingot.
- (2) For test samples used in other steels than steel plates, steels not greater than 10 tonnes in mass (having the same cross-sectional dimensions and being from the same cast manufactured by the same process) are to be treated as one lot, and one test sample is to be taken from each lot.
- (3) The requirements specified in **301. 6 (4)** are to be applied to the selection of the test samples.

Table 2.1.18-1 Impact Test Temperature of Steels Specified in Pt 7, Ch 5. (2017) (2023)

Grade	Thickness $t$ (mm)	Test temp (°C) <sup>(1)</sup>
<i>RL 235A</i> <i>RL 235B</i> <i>RL 325A</i> <i>RL 325B</i> <i>RL 355</i>	$t \leq 25$	-20 or (Td-5) <sup>(2)</sup>
	$25 < t \leq 30$	-20 or (Td-10) <sup>(2)</sup>
	$30 < t \leq 35$	-20 or (Td-15) <sup>(2)</sup>
	$35 < t \leq 40$	(Td-20)
	$40 < t \leq 50$	-20 or (Td-5) <sup>(2)(3)</sup>
	$40 < t \leq 45$	(Td-25) <sup>(4)</sup>
	$45 < t \leq 50$	(Td-30) <sup>(4)</sup>
	$50 < t$	<sup>(5)</sup>
<i>RL 1N255</i>	$t \leq 25$	-65
	$25 < t \leq 30$	-65 or (Td-10) <sup>(2)</sup>
	$30 < t \leq 35$	-65 or (Td-15) <sup>(2)</sup>
	$35 < t \leq 40$	-65 or (Td-20) <sup>(2)</sup>
	$40 < t \leq 45$	(Td-25) <sup>(6)</sup>
	$45 < t \leq 50$	(Td-30) <sup>(6)</sup>
<i>RL 2N255</i>	$t \leq 25$	-70
	$25 < t \leq 30$	-70 or (Td-10) <sup>(2)</sup>
	$30 < t \leq 35$	-70 or (Td-15) <sup>(2)</sup>
	$35 < t \leq 40$	-70 or (Td-20) <sup>(2)</sup>
	$40 < t \leq 45$	(Td-25) <sup>(6)</sup>
	$45 < t \leq 50$	(Td-30) <sup>(6)</sup>
<i>RL 3N355</i>	$t \leq 25$	-95
	$25 < t \leq 30$	-95 or (Td-10) <sup>(2)</sup>
	$30 < t \leq 35$	-95 or (Td-15) <sup>(2)</sup>
	$35 < t \leq 40$	-95 or (Td-20) <sup>(2)</sup>
	$40 < t \leq 45$	(Td-25) <sup>(6)</sup>
	$45 < t \leq 50$	(Td-30) <sup>(6)</sup>
<i>RL 5N390</i>	$t \leq 25$	-110
	$25 < t \leq 30$	-110 or (Td-10) <sup>(2)</sup>
	$30 < t \leq 35$	-110 or (Td-15) <sup>(2)</sup>
	$35 < t \leq 40$	-110 or (Td-20) <sup>(2)</sup>
	$40 < t \leq 45$	(Td-25) <sup>(6)</sup>
	$45 < t \leq 50$	(Td-30) <sup>(6)</sup>
<i>RL 9N490</i>	$t \leq 50$	-196 <sup>(6)</sup>

Table 2.1.18-1 Impact Test Temperature of Steels Specified in Pt 7, Ch 5.(cont'd) (2017) (2023)

NOTES:

- (1)  $T_d$  is the design temperature (°C).
- (2) The test temperature is to be the lower of those specified above.
- (3) In addition, post-weld stress relief heat treatment shall be performed. Exemption to post-weld stress relief heat treatment based on alternative approach (e.g. Engineering Critical Assessment) shall be approved by the Society or shall be to recognized standards.
- (4) Applies to cargo tank other than type C.
- (5) This may be accepted by approval of the Society. And the test temperature is to be as deemed appropriate by the Society.
- (6) A further set of impact test at mid thickness for products with  $40 < t \leq 50$  is required

### 7. Selection of test specimens

- (1) Tensile test specimens are to be taken according to the requirements specified in **301. 7** (2).
- (2) Impact test specimens are to be taken according to the following (a) and (b):
  - (a) The requirements specified in **301. 7** (3) are to apply.
  - (b) For steel plates, the test specimens are to be taken with their longitudinal axis normal (T direction) to the final direction of rolling; for other steels than steel plates, they are to be taken with their longitudinal axis parallel (L direction) to the final direction of rolling.

### 8. Surface inspection and verification of dimensions

Surface inspection and verification of dimensions are to be in accordance with the requirements in **301. 8**. The minus tolerance for the nominal thickness of plates is to be 0.25 mm.

### 9. Retest procedures

Where the tensile test and impact tests from the first test specimen selected fails to meet the requirements, additional tests may be conducted according to the requirements given in **109**.

### 10. Marking

- (1) Steels which have satisfactorily complied with the required tests are to be marked with the identification mark in accordance with the requirements in **110**.
- (2) For steels to which the requirements given in Notes (2) of **Table 2.1.17** and Notes (7) of **Table 2.1.18** have been applied, "TM" and impact test temperature "T" are to be suffixed to the markings. (e.g. *RL 325TM-50T*)
- (3) For steel to which the requirements given in **5**. (3), the specified value of the maximum yield stress or proof stress and "A" are to be suffixed to the markings. (e.g. *RL 325A-440A*) (2023)

## 305. Rolled stainless steels

### 1. Application

- (1) These requirements are to apply to the rolled stainless steels (hereinafter referred to as "steels") for tanks in low temperature service or corrosion-resisting service.
- (2) Austenitic-ferritic stainless steel (hereinafter referred to as "duplex stainless steels") not exceeding 75 mm in thickness are to be as in accordance with the Guidance relating to the Rules specified by the Society. **[See Guidance]**
- (3) The requirements other than those specified in **305**. are applicable to the requirements in **301**.
- (4) Steels other than those specified in **305**. are to comply with the requirements in **101. 2**.

### 2. Kinds

Steels are classified as specified in **Table 2.1.19**.

Table 2.1.19 Grades and Chemical Composition of Stainless Steels (2020) (2021)

Grade	Chemical composition (%)																	
	<i>C</i>	<i>Si</i>	<i>Mn</i>	<i>P</i>	<i>S</i>	<i>Ni</i>	<i>Cr</i>	<i>Mo</i>	<i>N</i>	<i>Others</i>								
<i>RSTS304</i>	0.08 max.	1.00 max.	2.00 max.	0.040 max.	0.030 max.	8.00~10.50	18.00~20.00	-	-	-								
<i>RSTS304L</i>	0.030 max.					8.00~13.00												
<i>RSTS304M1</i>	0.08 max.					7.00~10.50												
<i>RSTS304M2</i>						7.50~10.50												
<i>RSTS304LN</i>	0.030 max.	1.00 max.	2.00 max.	0.040 max.	0.030 max.	8.50~11.50	17.00~19.00	-	0.10~0.25	Nb ≤ 0.15								
<i>RSTS309S</i>	0.08 max.					1.50 max.	12.00~15.00		22.00~24.00		-							
<i>RSTS310S</i>							19.00~22.00		24.00~26.00									
<i>RSTS316</i>	0.030 max.					1.00 max.	2.00 max.		0.040 max.		0.030 max.	10.00~14.00	16.00~18.00	2.00~3.00	-	-		
<i>RSTS316L</i>												10.00~15.00						
<i>RSTS316N</i>												0.08 max.					10.00~14.00	0.10~0.22
<i>RSTS316LN</i>												0.030 max.					10.50~14.50	16.50~18.50
<i>RSTS317</i>	0.08 max.					1.00 max.	2.00 max.		0.040 max.		0.030 max.	11.00~15.00	18.00~20.00	3.00~4.00	-	-		
<i>RSTS317L</i>	0.030 max.														-			
<i>RSTS317LN</i>															0.10~0.20			
<i>RSTS321</i>	0.08 max.					1.00 max.	2.00 max.		0.040 max.		0.030 max.	9.00~13.00	17.00~19.00	-	-	Ti ≥ 5×C		
<i>RSTS347</i>																Nb ≥ 10×C		

### 3. Heat treatment

The steels are generally to receive a solid solution treatment.

### 4. Chemical composition

The chemical composition of steels is to comply with the requirements given in **Table 2.1.19**.

### 5. Mechanical properties

- (1) The mechanical properties of steels are to comply with the requirements given in **Table 2.1.20**.  
**[See Guidance]**

**Table 2.1.20 Mechanical Properties of Stainless Steels**

Grade	Tensile			Hardness test		
	Yield strength (N/mm <sup>2</sup> )	Tensile strength (N/mm <sup>2</sup> )	Elongation(%) ( $L = 5.65\sqrt{A}$ )	Brinell $H_{BW}$	Rock well $H_{RB}$	Vickers $H_V$
<i>RSTS304</i>	205 min.	520 min.	40 min.	187 max.	90 max.	200 max.
<i>RSTS304L</i>	175 min.	480 min.				
<i>RSTS304M1</i>	275 min.	550 min.	35 min.	217 max.	95 max.	220 max.
<i>RSTS304M2</i>	345 min.	690 min.		248 max.	100 max.	260 max.
<i>RSTS304LN</i>	245 min.	550 min.	40 min.	187 max.	90 max.	200 max.
<i>RSTS309S</i>	205 min.	520 min.				
<i>RSTS310S</i>						
<i>RSTS316</i>						
<i>RSTS316L</i>	175 min.	480 min.				
<i>RSTS316N</i>	275 min.	550 min.	35 min.	217 max.	95 max.	220 max.
<i>RSTS316LN</i>	245 min.					
<i>RSTS317</i>	205 min.	520 min.	40 min.	187 max.	90 max.	200 max.
<i>RSTS317L</i>	175 min.	480 min.				
<i>RSTS317LN</i>	245 min.	550 min.				
<i>RSTS321</i>	205 min.	520 min.				
<i>RSTS347</i>			187 max.	90 max.	200 max.	

- (2) The minimum yield strength specified in **Table 2.1.20** may be altered to other values subject to the approval of the Society. In this case, minimum yield strength and indication symbol of heat treatment specified in **301. 4** will be added after the steel grade mark.(eg. : *RSTS 316LN - 400TM*) (2019)
- (3) The results of hardness test, according to the test method, are to comply with the requirements given in **Table 2.1.20**.
- (4) Other tests on notch toughness or corrosion resistance may be required, where deemed necessary by the Society. **[See Guidance]**

#### 6. Selection of test samples

- (1) One test sample is to be taken from every similarly heat treated plate as rolled directly from one slab or ingot.
- (2) The requirements provided in **301. 6** (4) are to be applied to the selection of the test samples.

#### 7. Selection of test specimens

- (1) Tensile test specimens are to be taken according to the requirements specified in **301. 7** (2).
- (2) The hardness test specimen may be a portion of tensile test specimen.

#### 8. Tolerance for thickness

Surface inspection and verification of dimensions are to be in accordance with the requirements in **301. 8** The minus tolerance for the nominal thickness of plates is to be 0.25 mm.

#### 9. Marking

Steels which have satisfactorily complied with the required tests are to be marked with identification mark in accordance with the requirements in **110.**



## 10. Forming

The cold deformation limit of the rolled stainless steels is to be in accordance with the Guidance specially specified by the Society. **【See Guidance】**

### 306. Round bars for chain

#### 1. Application

- (1) These requirements are to apply to the rolled round bars (hereinafter referred to as "Chain bars") for chain specified in **Pt 4, Ch 8, Sec 4**.
- (2) Chain bars for manufacture of offshore mooring chain are to be in accordance with the Guidance relating to the Rules specified by the Society. **【See Guidance】**
- (3) The requirements other than those specified in **306**, are applicable to the requirements in **301**.
- (4) Chain bars having characteristics differing from those specified in **306**, are to comply with the requirements in **101. 2**.

#### 2. Kinds

The chain bars are classified as specified in **Table 2.1.21**.

**Table 2.1.21 Grades of Chain Bars**

Grade		Application	used for
Grade 1 chain bar	<i>RSBC31</i>	Un-studded chain Grade 1 chain	Ship's stud link anchor chain cables and accessories
Grade 2 chain bar	<i>RSBC50</i>	Grade 2 chain	
Grade 3 chain bar	<i>RSBC70</i>	Grade 3 chain	

#### 3. Deoxidation practice and chemical composition

The deoxidation practice and chemical composition of each grade are to comply with the requirements given in **Table 2.1.22**. Elements other than specified in **Table 2.1.22** may be added subject to a special approval by the Society.

**Table 2.1.22 Deoxidation Practice and Chemical Composition (%)**

Grade	Deoxidation	<i>C</i>	<i>Si</i>	<i>Mn</i>	<i>P</i>	<i>S</i>	<i>Al</i> <sup>(1)</sup>
<i>RSBC31</i>	Killed	0.20 max.	0.15~0.35	0.40 min.	0.040 max.	0.040 max.	-
<i>RSBC50</i> <sup>(2)</sup>	Fine-grained	0.24 max.	0.15~0.55	1.60 max.	0.035 max.	0.035 max.	0.020 min.
<i>RSBC70</i> <sup>(2)</sup>	killed	0.36 max.	0.15~0.55	1.00~1.90	0.035 max.	0.035 max.	0.020 min.

NOTE:  
 (1) *Al* content is to be represented by the total *Al* content and may be replaced partly by other fine graining elements.  
 (2) If the Society agrees, additional alloying elements may be added.

#### 4. Heat treatment

Chain bars are to be as rolled condition.

#### 5. Mechanical properties

The mechanical properties of chain bars are to comply with the requirements given in **Table 2.1.23**.

#### 6. Selection of test sample

- (1) Chain bars not greater than 50 tonnes in weight (from the same cast manufactured by the same process) are to be treated as one lot, and one test sample largest in diameter is to be taken from each lot.

- (2) Test sample mentioned in above (1), prior to sampling, must be subjected to the heat treatment provided for the finished chain cable. Details of the heat treatment must be indicated by the chain cable manufacturer. In case of no indication, heat treatment of the test sample is to comply with the requirements given in **Pt.4, Sec.8 406**. for each grade.

**Table 2.1.23 Mechanical Properties**

Grade	Tensile test				Impact test <sup>(1)(2)</sup>	
	Yield strength (N/mm <sup>2</sup> ) <sup>(3)</sup>	Tensile strength (N/mm <sup>2</sup> ) <sup>(3)</sup>	Elongation(%) (L=5d)	Reduction of area (%)	Test temp (°C)	Average absorbed energy (J)
RSBC31	-	370~490 <sup>(4)</sup>	25 min.	-	-	-
RSBC50	295 min.	490~690	22 min.	-	0	27 min. <sup>(2)</sup>
RSBC70	410 min.	690 min.	17 min.	40 min.	0 <sup>(4)</sup>	60 min. <sup>(4)</sup>

NOTES:

(1) When the absorbed energy of two or more test specimens among a set of test specimens is less in value than the specified average absorbed energy or when the absorbed energy of a single test specimen is less in value than 70 % of the specified average absorbed energy, the test is considered to have failed.

(2) For RSBC50 which will be heat treated according to **Pt 4, Ch 8, 405**. no impact testing is required.

(3) Impact test of RSBC 70 may be carried out at the temperature of -20°C where approved by the Society. In this case, minimum mean absorbed energy is to be not less than 35 J.

(4) Lower limit of tensile strength of RSBC31 may be 300 N/mm<sup>2</sup> with the approval of the Society.

## 7. Selection of test specimens

- (1) Test specimens are to be taken in accordance with the **Table 2.1.24**.

**Table 2.1.24 Number of test specimens**

Grade	Number of tensile test specimens	Number of impact test specimens
RSBC 31	1 piece	-
RSBC 50	1 piece	1 set (3 piece) <sup>(1)</sup>
RSBC 70	1 piece	1 set (3 piece)

NOTES:

(1) In case where note (2) of **Table 2.1.23** is applied, no impact test specimen need to be taken.

- (2) The test specimens are to be taken with their longitudinal axis parallel to the final direction of rolling.
- (3) The tensile and impact test specimens are to be taken from the test sample in the longitudinal direction at a depth of 1/6 diameter from the surface or as close as possible to this position. (See **Fig 2.1.5**)

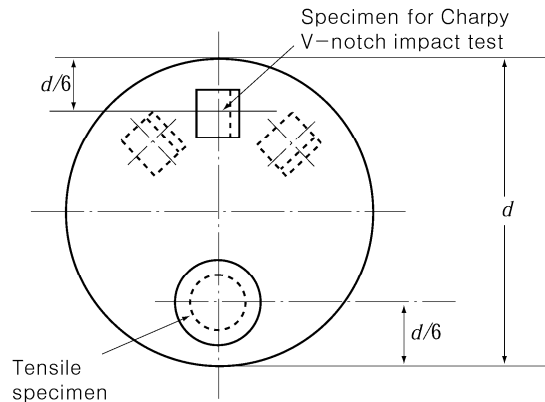


Fig 2.1.5 Selection of test specimens

(4) The longitudinal axis of the notch is to correspond approximately to the radial direction of each test specimen.

### 8. Surface inspection and verification of dimensions

- (1) Surface inspection for all grades is to be carried out and it is to be confirmed that there are no harmful defects.
- (2) The diameter and roundness of all grades of chain bars are to be within the tolerances specified in **Table 2.1.25**.

Table 2.1.25 Dimensional tolerance

Nominal Diameter (mm) <sup>(1)</sup>	Tolerance on diameter (mm)	Tolerance on roundness ( $d_{max} - d_{min}$ ) (mm) <sup>(2)</sup>
less than 25	-0, +1.0	0.6 max.
25 ~ 35	-0, +1.2	0.8 max.
36 ~ 50	-0, +1.6	1.1 max.
51 ~ 80	-0, +2.0	1.50 max.
81 ~ 100	-0, +2.6	1.95 max.
101 ~ 120	-0, +3.0	2.25 max.
121 ~ 160	-0, +4.0	3.00 max.

NOTES:  
 (1) For nominal diameter of bar materials which have more than 161 mm, dimensional tolerances are to be as deemed appropriate by the Society.  
 (2)  $d_{max}$  and  $d_{min}$  mean the maximum and minimum diameter of a round bar.

### 9. Retest procedures

- (1) Where the tensile test and impact tests from the first test specimen selected fails to meet the requirements, additional tests may be conducted according to the requirements given in **109**.
- (2) If failure to pass the tensile test or impact test is definitely attributable to improper heat treatment of the test sample, a new test sample may be taken from the same piece and reheat treated. The complete test (both tensile and impact test) is to be repeated; and the original results obtained may be disregarded.

### 10. Marking

Chain bars which have satisfactorily complied with the required tests are to be marked with identification marks in accordance with the requirements in **110**.

### 307. Rolled steel bars for boiler

#### 1. Application

- (1) These requirements are to apply to hot rolled steel bars intended to be used for the stay bolts for boilers (hereinafter referred to as "steel bars").
- (2) The steel bars having characteristics differing from those specified in **307.** are to comply with the requirements of **101. 2.**

#### 2. Kinds

The steel bars are classified as specified in **Table 2.1.26.**

**Table 2.1.26 Grades and Chemical Composition**

Grade	Chemical composition (%)		
	C	S	P
<i>RSB 42</i>	0.30 max.	0.04 max.	0.05 max.
<i>RSB 46</i>	0.33 max.		

#### 3. Heat treatment

The heat treatment of steel bars is to be as deemed appropriate by the Society. **[See Guidance]**

#### 4. Chemical composition

The chemical composition of steel bars is to comply with the requirements given in **Table 2.1.26.**

#### 5. Mechanical properties

The mechanical properties of steel bars are to comply with the following requirements.

- (1) The tensile test of steel bars is to comply with the requirements given in **Table 2.1.27.**

**Table 2.1.27 Mechanical Properties**

Grade	Yield strength (N/mm <sup>2</sup> )	Tensile strength (N/mm <sup>2</sup> )	Elongation(%) ( $L = 5.65\sqrt{A}$ )
<i>RSB 42</i>	225 min.	410~490	24 min.
<i>RSB 46</i>	245 min.	450~540	22 min.

NOTE:  
The required value of yield strength for the steel bars exceeding 100 mm in diameter may be taken as 205 N/mm<sup>2</sup> for *RSB 42* and 225 N/mm<sup>2</sup> for *RSB 46*, regardless of the above requirements.

- (2) The bend test specimen is to stand being bent cold through 180 degrees without cracking on the outside of the bent portion to an inside radius given in **Table 2.1.28.**

**Table 2.1.28 Bend Test**

Dia. of bar (mm)	Ratio of inside radius of bend to diameter of test specimen	
	<i>RSB 42</i>	<i>RSB 46</i>
$d \leq 25$	$\frac{3}{4}$	1
$25 < d \leq 50$	1	$1\frac{1}{4}$
$50 < d \leq 75$	$1\frac{1}{4}$	
$75 < d$		

## 6. Selection of test samples

For the test samples of steel bars, steel bars which belong to the same cast manufactured by the same process and where the amount of scatter is to be less than 10 mm in diameter, are to be treated as one lot, and test samples are to be taken from each lot according to the mass of the lot and to the requirements provided in **Table 2.1.29**.

**Table 2.1.29 Number of Test Samples**

Weight of group (ton)	Number of test samples
25 and under	1 each
Over 25 up to 30	2 each
Over 30	2 each plus 1 each for each 10 tons of excess or fraction thereof

## 7. Selection of test specimens

- (1) Each one piece of tensile and bend test specimen is to be taken from one test sample.
- (2) Test specimens are to be taken with their longitudinal axis parallel to the final direction of rolling.
- (3) Tensile test specimens are to be taken from the sample in the longitudinal direction at a depth of 1/6 diameter from the surface or as close as possible to this position. (See **Fig 2.1.5**)

## 8. Tolerance for diameter

The tolerance for diameter of the steel bars is to comply with the requirements in **Table 2.1.30**.

**Table 2.1.30 Tolerance for Diameter**

Diameter of bar (mm)	Tolerance
$d < 16$	$\pm 0.4$ mm
$16 \leq d < 28$	$\pm 0.5$ mm
$28 \leq d$	$\pm 1.8$ %

## 9. Marking

Steel bars which have satisfactorily complied with the required tests are to be marked with the identification mark in accordance with the requirements in **110**.

## 308. High strength steels for welded structures (2017)

### 1. Application

- (1) The requirements given in **308** are to apply to hot-rolled, fine-grain, weldable high strength structural steels intended for use in marine and offshore structural applications, tanks of liquefied gas carriers and process pressure vessels (hereinafter referred to as "steels")
- (2) Any requirements regarding the steels over specified maximum thickness of **Table 2.1.32** are left to the discretion of the Society. **[See Guidance]**
- (3) Product forms other than rolled steels, such as seamless tubulars, may be provided to the requirements given in **308**.
- (4) The requirements other than those specified in **308** are applicable to the requirements in **301**.
- (5) Steels having characteristics differing from those specified in **308** are to comply with the requirements in **101. 2**.

### 2. Kinds

Steels are classified as specified in **Table 2.1.31**.

**Table 2.1.31 Grade of Steels**

Kind		Grade
Weldable high strength steel	Plates, wide flats, sections, bars and seamless tubulars	AH43, DH43, EH43, FH43
		AH47, DH47, EH47, FH47
		AH51, DH51, EH51, FH51
		AH56, DH56, EH56, FH56
		AH63, DH63, EH63, FH63
		AH70, DH70, EH70, FH70
		AH90, DH90, EH90
		AH97, DH97, EH97

### 3. Manufacturing process

- (1) The maximum thickness of slab, billet or bloom from the continuous casting process is to be at the manufacturer's discretion. The rolling reduction ratio of slab, billet, bloom or ingot is not to be less than 3:1 unless agreed at the time of approval.
- (2) The maximum thickness by heat treatment and grade is to comply with the requirements given in **Table 2.1.32**.
- (3) Vacuum degassing is to be used for all steels with enhanced through-thickness properties and with specified yield point of 690 N/mm<sup>2</sup>, 890 N/mm<sup>2</sup>, 960 N/mm<sup>2</sup>.
- (4) The steel is to be fine grain treated, and is to have a fine grain structure. The fine grain practice is to be as detailed in the manufacturing specification. **【See Guidance】**
- (5) The steels is to contain nitrogen binding elements as detailed in the manufacturing specification. Also see note (4) in **Table 2.1.33**.
- (6) Steels approved by the procedures given in Manufacturing Process Approval with respect to Heat Treatment are suitable for stress relieving heat treatment such as post-weld heat treatment and stress relieving heat treatment after cold forming for the purpose of reducing the risk of brittle fracture, increasing the fatigue lifetime and dimensional stability for machining.

**Table 2.1.32 Max. thickness by heat treatment and grade**

Heat treatment <sup>(1)</sup>	Max. thickness (mm)			
	Plates	Sections	Bars	Tubulars
<i>N</i>	250 <sup>(3)</sup>	50	250	65
<i>CR</i>	150	<sup>(2)</sup>		
<i>TMCP</i>	150	50	–	–
<i>QT</i>	150 <sup>(3)</sup>	50	–	50

NOTE:

- (1) The definition of heat treatment is in accordance with note (1) of **Table 2.1.9** in **301**.
- (2) The maximum thickness limits of sections, bars and tubulars produced by CR process route are less than those manufactured by N route, and are to be at the discretion of the Society.
- (3) Approval for N steels with thickness larger than 250 mm and QT steels with thickness larger than 150 mm is subject to the special consideration of the Society.

### 4. Deoxidation practice and chemical composition

- (1) The deoxidation practice and chemical composition of steels are to comply with the requirements given in **Table 2.1.33**. Where deemed necessary, other elements than specified in **Table 2.1.33** may be added. Elements used for alloying, nitrogen binding, and fine grain treatment, and as well as the residual elements are to be as detailed in the manufacturing specification.

- (2) The maximum values for carbon equivalent( $C_{eq}$  or CET) and cold cracking susceptibility( $P_{cm}$ ) are to comply with the requirement in **Table 2.1.34**.

#### 5. Heat treatment

The steels are to be in heat treatment approved by the Society in accordance with the follows and **Table 2.1.33**.

- (1) Normalized(N)
- (2) Controlled rolling(CR)
- (3) Thermo-mechanical controlled rolling(TMCP)
  - (a) Thermo-mechanical Rolling(TM)
  - (b) TM with accelerated cooling(TM+AcC)
  - (c) TM with direct quenching followed by tempering (TM+DQ+T)
- (4) Quenched and Tempered(QT)

#### 6. Mechanical properties

- (1) The mechanical properties of steels are to comply with the requirements given in Table 2.1.35.
- (2) Where deemed necessary by the Society, other test on notch-toughness and weldability may be required in addition to the tests specified in **Table 2.1.35**. **[See Guidance]**

#### 7. Selection of test samples

- (1) Tensile test sample is to be randomly selected from each batch that is to be less than or equal to 25 tonnes, and to be from the same cast, in the same heat treatment and of the same thickness. **[See Guidance]**
- (2) Impact test sample is to be selected as follows;
  - (a) For steels plates in N/CR or TMCP condition, test sample is to be taken from each piece.
  - (b) For steels in QT condition, test sample is to be taken from each individually heat treated part thereof.
  - (c) For sections, bars and tubulars, test sample is to be taken from each batch of 25 tonnes or fraction thereof. **[See Guidance]**
- (3) The requirements specified in **301. 6 (4)** are to be applied to the selection of the test samples.

Table 2.1.33 Heat treatment, Deoxidation Practice and Chemical Composition (%)

Heat treatment (1)	Grade	Deoxidation practice	Chemical composition <sup>(2)(8)</sup>														
			C (%)	Si (%)	Mn (%)	P <sup>(3)</sup> (%)	S <sup>(3)</sup> (%)	Cu (%)	Cr <sup>(5)</sup> (%)	Ni <sup>(6)</sup> (%)	Mo <sup>(5)</sup> (%)	Al <sup>(4)</sup> total (%)	Nb <sup>(5)</sup> (%)	V <sup>(5)</sup> (%)	Ti <sup>(5)</sup> (%)	N (%)	O <sup>(7)</sup> (ppm)
N, CR	AH 43, AH 47, DH 43, DH 47	Fully killed fine grain	0.2 max.	0.6 max.	1.0~1.7	0.03 max.	0.025 max.	0.55 max.	0.3 max.	0.8 max.	0.1 max.	0.02 min.	0.05 max.	0.2 max.	0.05 max.	0.025 max.	-
	0.18 max.		0.025 max.			0.02 max.											
TM CP	AH 43, AH 47, AH 51, AH 56, AH 63, AH 70, AH 90, DH 43, DH 47, DH 51, DH 56, DH 63, DH 70		0.16 max.	0.6 max.	1.0~1.7	0.025 max.	0.015 max.	0.55 max.	0.5 max.	2.0 max.	0.5 max.	0.02 min.	0.05 max.	0.12 max.	0.05 max.	0.025 max.	-
	0.14 max.		0.02 max.			0.01 max.	50 max.										
QT	AH 43, AH 47, AH 51, AH 56, AH 63, AH 70, AH 90, AH 97, DH 43, DH 47, DH 51, DH 56, DH 63, DH 70		0.18 max.	0.8 max.	1.7 max.	0.025 max.	0.015 max.	0.5 max.	1.5 max.	2.0 max.	0.7 max.	0.018 min.	0.06 max.	0.12 max.	0.05 max.	0.015 max.	-
	0.02 max.					0.01 max.	30 max.										

NOTE:

- (1) The definition of heat treatment is in accordance with note (1) of Table 2.1.9 in 301..
- (2) The chemical composition is to be determined by ladle analysis and is to meet the approved manufacturing specification at the time of approval.
- (3) For sections the P and S content can be 0.005 % higher than the value specified in the table.
- (4) The total aluminium to nitrogen ratio is to be a minimum of 2:1. When other nitrogen binding elements are used, the minimum Al value and Al/N ratio do not apply.
- (5) Total Nb+V+Ti ≤ 0.26 % and Mo+Cr ≤ 0.65%, not applicable for QT steels.
- (6) Higher Ni content may be approved at the discretion of the Society.
- (7) The requirement on maximum Oxygen content is only applicable to DH90, EH90, DH97 and EH97.
- (8) when boron is deliberately added for enhancement of hardenability of the steels, the maximum content of the boron content is not to be higher than 0.005%; and the analysis result is to be reported.



Table 2.1.34 Carbon equivalent( $C_{eq}$  or  $CET$ ) and Cold cracking susceptibility( $P_{cm}$ )

Grade	Heat treatment	Carbon equivalent (%)						CET <sup>(1)(2)</sup>	Pcm <sup>(1)(3)</sup>
		Ceq <sup>(1)</sup>							
		Plates			Sections	Bars	Tubulars	All	All
		$t \leq 50$ (mm)	$50 < t \leq 100$ (mm)	$100 < t \leq 250$ (mm)	$t \leq 50$ (mm)	$t \leq 250$ (mm)	$t \leq 65$ (mm)	All	All
AH 43, DH 43, EH 43, FH 43	N, CR	0.46 max.	0.48 max.	0.52 max.	0.47 max.	0.53 max.	0.47 max.	-	-
	TMCP	0.43 max.	0.45 max.	0.47 max.	0.44 max.	-	-	-	-
	QT	0.45 max.	0.47 max.	0.49 max.	-	-	0.46 max.	-	-
AH 47, DH 47, EH 47, FH 47	N, CR	0.50 max.	0.52 max.	0.54 max.	0.51 max.	0.55 max.	0.51 max.	0.25 max.	-
	TMCP	0.45 max.	0.47 max.	0.48 max.	0.46 max.	-	-	0.30 max.	0.23 max.
	QT	0.47 max.	0.48 max.	0.50 max.	-	-	0.48 max.	0.32 max.	0.24 max.
AH 51, DH 51, EH 51, FH 51	TMCP	0.46 max.	0.48 max.	0.50 max.	-	-	-	0.32 max.	0.24 max.
	QT	0.48 max.	0.50 max.	0.54 max.	-	-	0.50 max.	0.34 max.	0.25 max.
AH 56, DH 56, EH 56, FH 56	TMCP	0.48 max.	0.50 max.	0.54 max.	-	-	-	0.34 max.	0.25 max.
	QT	0.56 max.	0.60 max.	0.64 max.	-	-	0.56 max.	0.36 max.	0.28 max.
AH 63, DH 63, EH 63, FH 63	TMCP	0.50 max.	0.52 max.	-	-	-	-	0.34 max.	0.26 max.
	QT	0.56 max.	0.60 max.	0.64 max.	-	-	0.58 max.	0.38 max.	0.30 max.
AH 70, DH 70, EH 70, FH 70	TMCP	0.56 max.	-	-	-	-	-	0.36 max.	0.30 max.
	QT	0.64 max.	0.66 max.	0.70 max.	-	-	0.68 max.	0.40 max.	0.33 max.
AH 90, DH 90, EH 90	TMCP	0.60 max.	-	-	-	-	-	0.38 max.	0.28 max.
	QT	0.68 max.	0.75 max.	-	-	-	-	0.40 max.	-
AH 97, DH 97, EH 97	QT	0.75 max.	-	-	-	-	-	0.40 max.	-

NOTE:

(1)  $C_{eq}$ ,  $CET$  and  $P_{cm}$  are to be obtained from the following formula:

$$C_{eq} = C + \frac{Mn}{6} + \frac{Cr + Mo + V}{5} + \frac{Ni + Cu}{15} (\%), \quad CET = C + \frac{(Mn + Mo)}{10} + \frac{(Cr + Cu)}{20} + \frac{Ni}{40} (\%),$$

$$P_{cm} = C + \frac{Si}{30} + \frac{Mn}{20} + \frac{Cu}{20} + \frac{Ni}{60} + \frac{Cr}{20} + \frac{Mo}{15} + \frac{V}{10} + 5B$$

(2) For steel of minimum yield strength 460 N/mm<sup>2</sup> and higher, CET may be used instead of  $C_{eq}$  at the discretion of the manufacturer.

(3) For  $TMCP$  and  $QT$  steels with carbon content not more than 0.12%, the cold cracking susceptibility  $P_{cm}$  for evaluating weldability may be used instead of carbon equivalent of  $C_{eq}$  or  $CET$  at manufacturer's discretion.

Table 2.1.35 Mechanical Properties

Grade	Heat treatment	Tensile test <sup>(1)</sup>							Impact test <sup>(1)(2)</sup>		
		Yield strength (N/mm <sup>2</sup> )			Tensile strength (N/mm <sup>2</sup> )		Elongation (%) <sup>(3)</sup> ( $L=5.65\sqrt{A}$ )		Test temp. <sup>(4)</sup> (°C)	Average absorbed energy (J)	
		Nominal thickness t (mm) <sup>(5)</sup>			Nominal thickness t (mm) <sup>(5)</sup>						
		3 ≤ t ≤ 50	50 < t ≤ 100	100 < t ≤ 250	3 ≤ t ≤ 100	100 < t ≤ 250	L	T <sup>(6)</sup>	L	T	
AH 43	N, CR, TMCP, QT	420 min.	390 min.	365 min.	520~680	470~650	21 min.	19 min.	0	42 min.	28 min.
DH 43									-20		
EH 43									-40		
FH 43									-60		
AH 47	N, CR, TMCP, QT	460 min.	430 min.	390 min.	540~720	500~710	19 min.	17 min.	0	46 min.	31 min.
DH 47									-20		
EH 47									-40		
FH 47									-60		
AH 51	TMCP, QT	500 min.	480 min.	440 min.	590~770	540~720	19 min.	17 min.	0	50 min.	33 min.
DH 51									-20		
EH 51									-40		
FH 51									-60		
AH 56	TMCP, QT	550 min.	530 min.	490 min.	640~820	590~770	18 min.	16 min.	0	55 min.	37 min.
DH 56									-20		
EH 56									-40		
FH 56									-60		
AH 63	TMCP, QT	620 min.	580 min.	560 min.	700~890	650~830	17 min.	15 min.	0	62 min.	41 min.
DH 63									-20		
EH 63									-40		
FH 63									-60		
AH 70	TMCP, QT	690 min.	650 min.	630 min.	770~940	710~900	16 min.	14 min.	0	69 min.	46 min.
DH 70									-20		
EH 70									-40		
FH 70									-60		
AH 90	TMCP, QT	890 min.	830 min.	-	940~1100	-	13 min.	11 min.	0	69 min.	46 min.
DH 90									-20		
EH 90									-40		
AH 97	QT	960 min.	-	-	980~1150	-	12 min.	10 min.	0	69 min.	46 min.
DH 97									-20		
EH 97									-40		

NOTE:

- (1) L (or T) denotes that the longitudinal axis of the test specimen is arranged parallel (or transverse) to the final direction of rolling
- (2) When the absorbed energy of two or more test specimens among a set of test specimens is less in value than the specified average absorbed energy or when the absorbed energy of a single test specimen is less in value than 70% of the specified average absorbed energy, the test is considered to have failed.
- (3) The minimum elongation for R1B test specimen (L=200mm) is to be in compliance with the requirements given in Table 2.1.36.
- (4) Impact test temperature for steels specified in Pt 7, Ch 5 are given in Table 2.1.37.
- (5) For plates and sections for applications, such as racks in offshore platforms etc, where the design requires that tensile properties are maintained through the thickness, a decrease in the minimum specified tensile properties is not permitted with an increase in the thickness.
- (6) In the case of product forms other than plates and wide flats where longitudinal tests are agreed, the elongation values are to be 2 percentage units above those transverse requirements as listed in this Table.

Table 2.1.36 The minimum elongation for *R1B* test specimen ( $L=200\text{mm}$ )<sup>(1)</sup>

Grade	Thickness $t$ (mm)						
	$t \leq 10$	$10 < t \leq 15$	$15 < t \leq 20$	$20 < t \leq 25$	$25 < t \leq 40$	$40 < t \leq 50$	$50 < t \leq 70$
AH43, DH 43, EH 43, FH 43	11	13	14	15	16	17	18
AH47, DH 47, EH 47, FH 47	11	12	13	14	15	16	17
AH51, DH 51, EH 51, FH 51	10	11	12	13	14	15	16
AH56, DH 56, EH 56, FH 56	10	11	12	13	14	15	16
AH63, DH 63, EH 63, FH 63	9	11	12	12	13	14	15
AH70, DH 70, EH 70, FH 70	9 <sup>(2)</sup>	10 <sup>(2)</sup>	11 <sup>(2)</sup>	11	12	13	14

NOTE:

(1) This tabulated elongation minimum values are the requirements for testing specimen in transverse direction. Specimens of specified minimum yield strength 890 N/mm<sup>2</sup> and 960 N/mm<sup>2</sup> which are not included in this table are to be proportional specimens with a gauge length of  $L=5.65\sqrt{A}$ .

(2) For specified minimum yield strength 690 N/mm<sup>2</sup> plates with thickness  $\leq 20$  mm, round specimen R14A may be used instead of the flat tensile specimen. The minimum elongation for testing specimen in transverse direction is 14%.

Table 2.1.37 Impact Test Temperature for Steels specified in Pt 7, Ch 5

Grade	Thickness $t$ (mm)	Impact test		
		Test temp (°C)	Average absorbed energy ( $J$ )	
			L	T
<i>AH43, DH43, AH47, DH47</i> <i>AH51, DH51, AH56, DH56</i> <i>AH63, DH63, AH70, DH70</i>	$t \leq 20$	0	41 min.	27 min.
	$20 < t \leq 40$	-20		
	$40 < t \leq 50$	-30		
	$50 < t$	(1)		

NOTE: (1) Temperature is to be as deemed appropriate by the Society. **[See Guidance]**

## 8. Selection of test specimens

- (1) Tensile test specimens are to comply with the requirements shown in (a) to (c) below:
- Test specimens are to be cut with their longitudinal axes transverse to the final direction of rolling, except in the case of sections, bars, tubulars and rolled flats with a finished width of 600 mm or less, where the tensile specimens may be taken in the longitudinal direction.
  - Normally flat tensile test specimens with full thickness are to be prepared in such a manner as to maintain the rolling scale at least at one side.
  - When the capacity of the test machine is exceeded by the use of a full thickness specimen, sub-sized flat tensile specimens representing either the full thickness or half of the product thickness retaining one rolled surface are to be used. Alternatively, machined round test specimens may be used. The specimens are to be located at a position lying at a distance of  $t/4$  from the surface and additionally at  $t/2$  for thickness above 100 mm or as near as possible to these positions.
- (2) Impact test specimens are to be taken as follows:
- The Charpy V-notch impact test specimens for plates and wide flats over 600 mm in width are to be taken with their axes transverse to the final rolling direction. For other product forms, the impact tests are to be in the longitudinal direction.
  - Sub-surface test specimens will be taken in such a way that one side is not further away than 2 mm from a rolled surface, however, for material with a thickness in excess of 50 mm, impact tests shall be taken at the quarter thickness ( $t/4$ ) location and mid-thickness ( $t/2$ ).

(c) Impact test for a nominal thickness less than 6 mm are normally not required.

#### 9. Surface inspection and verification of dimensions

- (1) Surface inspection and verification of dimensions are to be in accordance with requirements specified in **301. 8**.
- (2) If required by the Society, ultrasonic examination is to be carried out in accordance with 301. 9 (2) for the requirement of internal soundness, and is to be performed in accordance with an approved standard.
- (3) For steels designated with improved through thickness properties, through thickness tensile tests are to be performed in accordance with **310.**. Subject to the discretion of the Society, through thickness tensile strength may be required to be not less than 80 % of the specified minimum tensile strength.

#### 10. Retest procedures

- (1) Where the tensile test from the first test specimen selected fails to meet the requirements, additional tests may be conducted according to the requirements given in **109. 1**.
- (2) Regarding the impact tests, additional tests are to be carried out according to the requirements given in **109. 2**.

#### 11. Marking

Steels which have satisfactorily complied with the required tests are to be marked with the identification mark in accordance with the requirements in **110**. For steels to which the requirements given in Note (4) of **Table 2.1.35** have been applied, the "impact test temperature T" are to be suffixed to the marking. (e.g. *DH63-25T*)

#### 12. Test certificates

The Surveyor is to be supplied with two copies, of the test certificates for all accepted materials. In addition to the description, dimensions, etc., of the material, the following particulars are to be included:

- (1) Purchaser's order number
- (2) Identification of the cast and piece
- (3) Manufacturer's identification
- (4) Identification of the grade of steel
- (5) Chemical analysis
- (6) Ceq, CET or Pcm value
- (7) Heat treatment condition and temperatures
- (8) Mechanical properties test results, including traceable test identification
- (9) Surface quality and inspection results
- (10) UT result, where applicable
- (11) Through thickness properties of **310.**, where applicable

### 309. Stainless clad steel plates

#### 1. Application

- (1) The requirements in **309**. are to apply to the stainless clad steels not exceeding 50 mm in thickness intended for tanks of ships carrying dangerous chemicals in bulk, tank circumference hull construction units and corrosion-resisting tanks (hereinafter referred to as "steel plates").
- (2) The requirements other than those specified in **309**. are to be in accordance with the requirements in **301.**.
- (3) Steel plates over 50 mm in thickness and having characteristics differing from those specified in **309**. are to comply with the requirements in **101. 2**.

#### 2. Process of manufacture

- (1) Manufacture of steel plates is to comply with the processes shown in (a) to (e) below:
  - (a) Rolling
  - (b) Explosive pressing
  - (c) Overlay rolling
  - (d) Cast rolling
  - (e) Explosive rolling

(2) Application of any other process of manufacture than those specified in (1) is left to the discretion of the Society. **【See Guidance】**

### 3. Structural metals

- (1) Base and clad materials for steel plates are to be mild & higher strength steel plates of rolled steels for hull specified in **301**, and steel plates of rolled stainless steels specified in **305**., respectively. In case of overlay rolling or cast rolling, clad materials are to comply with the specified chemical composition of welding materials or stainless steel casting applied as a clad. (2023)
- (2) The material grade marks are to be signified by a combination of base metal and clad material. (ex. *A + RSTS316*)

### 4. Heat treatment

The steel plates are to comply with the requirements for heat treatment of the base metal.

### 5. Mechanical properties **【See Guidance】**

- (1) The mechanical properties of steel plates are to comply with the requirements given in **Table 2.1.38**.

**Table 2.1.38 Mechanical Properties (2023)**

Grade	Tensile test <sup>(1)</sup>			Shearing strength test <sup>(3)</sup>	Impact test
	Yield strength (N/mm <sup>2</sup> )	Tensile strength (N/mm <sup>2</sup> )	Elongation (%)	Shearing strength (N/mm <sup>2</sup> )	
<i>A</i> <i>B</i> <i>D</i> <i>E</i>	235 min.	$\sigma_B$ min. <sup>(2)</sup>	To be complied with requirement for base metal	200 min.	To be complied with requirement for base metal
<i>AH32, AH36, DH32, DH36, EH32, EH36, FH32, FH36</i>	$\sigma_Y$ min. <sup>(2)</sup>				

NOTES:

(1) The tensile test specimen is to be R1B test specimen ( $L=200\text{mm}$ )

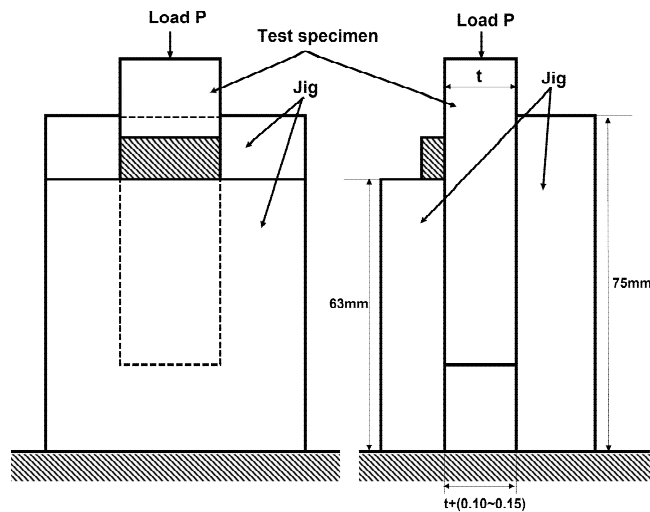
(2)  $\sigma_Y$  and  $\sigma_B$  is to be obtained from the following formulas:

$$\sigma_Y = \frac{t_1\sigma_{Y1} + t_2\sigma_{Y2}}{t_1 + t_2}, \quad \sigma_B = \frac{t_1\sigma_1 + t_2\sigma_2}{t_1 + t_2}$$

where:

- $\sigma_Y$  = Yield strength of steel plates (N/mm<sup>2</sup>)
- $\sigma_{Y1}$  = Specified minimum yield strength of base metal (N/mm<sup>2</sup>)
- $\sigma_{Y2}$  = Specified minimum yield strength of clad material (N/mm<sup>2</sup>)
- $\sigma_B$  = Tensile strength of steel plates (N/mm<sup>2</sup>)
- $\sigma_1$  = Specified minimum tensile strength of base metal (N/mm<sup>2</sup>)
- $\sigma_2$  = Specified minimum tensile strength of clad material (N/mm<sup>2</sup>)
- $t_1$  = Thickness of base metal (mm)
- $t_2$  = Thickness of clad material (mm)

(3) Any requirement for the procedure of shear strength test is left to **Fig 2.1.6** or the discretion of the Society. In case of overlay rolling, shear strength test may be omitted.



(Notes)

1. The dimensions of jig can be adjusted.
2. The clad material is peeled from the base metal parallel to the bonding surface.
3. Shear strength is to be obtained from the following formula:

$$\sigma_s = \frac{P}{S}$$

$\sigma_s$  : Shear strength for clad steel plates

P : Load

S : apparent bonding area ( $S=W \times 25$ , see Fig 2.1.7)

Fig 2.1.6 Test method for shear strength (2023)

- (2) Where deemed necessary by the Society according to the use of steel plates, tests on corrosion resistance may be required. **[See Guidance]**

#### 6. Selection of test samples

- (1) One test sample is to be taken from each steel plate, being from the same manufacturing process, which belong to the plate as rolled from a slab or ingot of a certain base metal. In case of overlay rolling, a separate test sample which is applied the same condition of manufacturing process can be made.
- (2) The requirements specified in 301. 6 (4) are to be applied to the selection of the test samples.

#### 7. Selection of test specimens

- (1) Tensile test specimens are to be taken according to the requirements specified in 301. 7 (2).
- (2) Impact test specimens are to be taken according to the requirements specified in 301. 7 (3). In this case, the thickness of the test specimens is to agree with that of the base metal from which the clad material has been removed.
- (3) Shearing strength test specimens are to be taken according to the requirements specified in the following (a) to (b):
  - (a) One test specimen is to be taken from one test sample.
  - (b) The size and dimensions of the test specimens, are to be determined according to Fig 2.1.7.

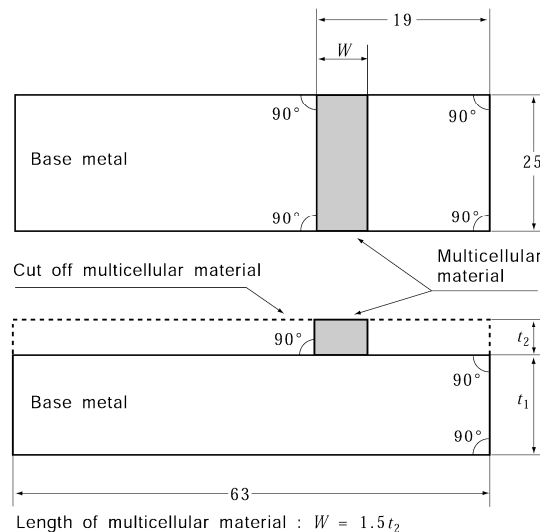


Fig 2.1.7 Size and Dimensions of Shearing Test Specimens (unit: mm)

### 8. Surface inspection and verification of dimensions

The minus tolerance for the nominal thickness of plates is left to the discretion of the Society.  
【See Guidance】

### 9. Quality and repair of defects 【See Guidance】

- (1) Each steel plate is to be subjected to ultrasonic testing. Any requirement for the test procedure is left to the discretion of the Society.
- (2) Each cladding defects does not exceed 50 mm in length and 20 cm<sup>2</sup> in area. All defect areas do not exceed 1.5 % of the total surface in question.
- (3) Any cladding defects over the length and area of (2) may be repaired by welding in accordance with the requirements given in 301. 9 (3)

### 10. Marking

- (1) The test certificates are to comply with the requirements given in 107. and are to contain the particulars as to the process of manufacture of steel plates and the thickness of the clad material.
- (2) Steel plates which have satisfactorily complied with the required tests are to be suffixed with the following marks relating to the process of manufacture of the steel plates, in addition to the marks showing the kinds of the base and clad materials. (e.g.  $A + RSTS316 - R$ )

Rolling	:	$[-R]$
Cast rolling	:	$[-ER]$
Explosive pressing	:	$[-B]$
Explosive rolling	:	$[-BR]$
Overlay rolling	:	$[-WR]$

## 310. Additional requirements for through thickness properties

### 1. Application

- (1) The requirements in 310. are to apply to hull structural rolled steels and weldable high strength steel plates and wide flats with thickness of 15 mm and over which is required improved through thickness properties to minimise the possibility of lamellar tearing during fabrication.
- (2) The requirements are applicable to the other steels than the material specified in (1) above, where deemed appropriate by the Society. 【See Guidance】

### 2. Through thickness properties

The through thickness properties of steels are to comply with the requirements given in Table 2.1.39 as the result of tensile tests whose specimens are taken in the through thickness direction of the product.

**Table 2.1.39 Through thickness properties**

Grade	Application	Reduction of area acceptance values <sup>(1)</sup>	
		Minimum average(%)	Minimum individual(%)
Z25	normal use	25	15
Z35	severe service condition	35	25

Note  
(1) The minimum average value for the reduction of area of at least 3 tensile test specimens taken in the through thickness direction must be that shown for the appropriate grade given in Table. Only one individual value may be below the minimum average but not less than minimum individual value shown for the appropriate grade.

**3. Deoxidation practice and chemical composition**

In addition to the requirements of the appropriate steel specification given in **301.** or **308.**, the maximum sulphur content is to be 0.008% determined by the ladle analysis.

**4. Selection of test specimens**

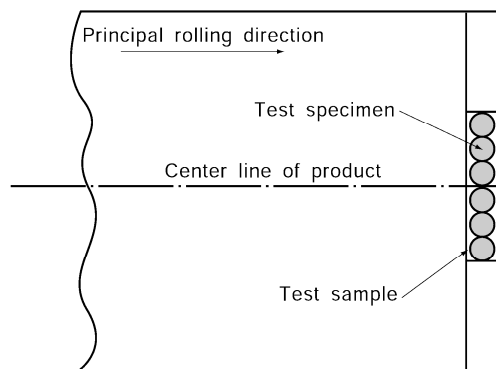
(1) For steel, of same thickness, belonging to the same charge and same heat treatment condition, one test sample is to be taken from each lot specified in **Table 2.1.40.**

**Table 2.1.40 Batch size dependent on product and sulphur content**

Product	S > 0.005%	S ≤ 0.005%
Plates	<P>	<50>
Wide flats of normal thickness ≤ 25mm	<10>	<50>
Wide flats of normal thickness > 25mm	<20>	<50>

Note  
(1) In the Table, <50>, <20> and <10> each indicate that steels not greater than 50, 20 and 10 tones are to be taken as one lot; <P> indicates that steel rolled directly from one slab or steel ingot is to be taken as one lot. The term "piece" is understood to mean the rolled product from a single slab or ingot if this is rolled directly into plates, sections or bars.

(2) The test samples are to be taken from one end (top of ingot when applicable) of the portion corresponding to the middle of the plates or flat bars as shown in **Fig 2.1.8.**



**Fig 2.1.8 Selection of Test Samples**



### 5. Selection of test specimens

- (1) Three round tensile test specimens are to be taken from one test sample in the through thickness direction.
- (2) The test specimens are to be taken according to the requirements for dimensions provided in **Table 2.1.41**.

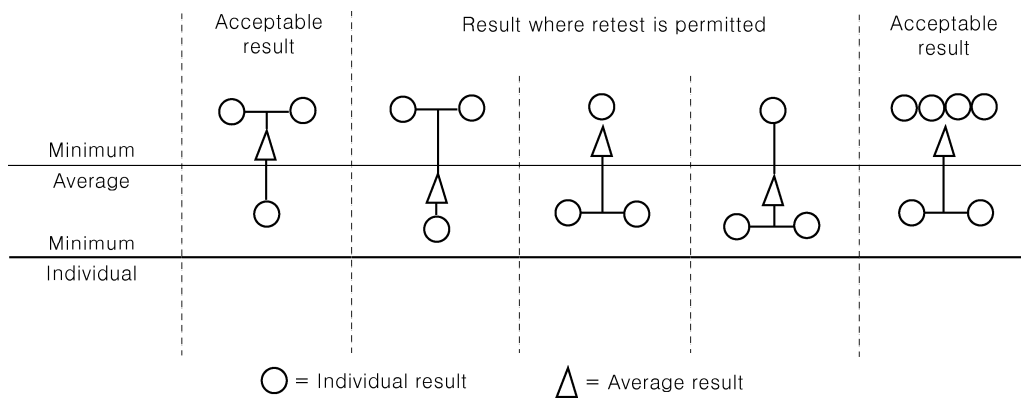
**Table 2.1.41 Dimensions of Specimen**

Product thickness $t$ (mm)	Diameter of test specimen $d$ (mm)	Parallel length $P$ (mm)
$15 \leq t \leq 25$	$d = 6$	$P \geq 2d$
$t > 25$	$d = 10$	$P \geq 2d$

- (3) Where the product thickness does not allow to prepare specimens of sufficient length suitable for the gripping jaws of the testing machine, the ends of the specimens may be built up by suitable welding methods. The welding is not to impair the portion of the specimen within the parallel length.

### 6. Retest procedure

- (1) Acceptance, rejection and retest criteria for the through thickness properties of steels are to comply with the requirements given in **Fig 2.1.9**.



**Fig 2.1.9 Acceptance, rejection and retest criteria for the through thickness properties of steels**

- (2) **Fig 2.1.9** shows the three cases where a retest situation is permitted. In these instances three more tensile tests are to be taken from the remaining test sample or remaining steel plates of same piece. The average of all 6 tensile tests is to be greater than the required minimum average with no greater than two results below the minimum average.
- (3) In the case of failure after retest, either the lot represented by the piece is rejected or each piece within the lot is required to be tested.
- (4) The test is considered invalid and further replacement test is required if the fracture occurs in the weld or heat affected zone.

### 7. Ultrasonic tests [See Guidance]

- (1) Ultrasonic testing should be carried out on each piece in the final supply condition.
- (2) Any requirement for the test procedure and acceptance criteria are left to the discretion of the Society. However, the probe frequency is to be of 4MHz in general.

### 8. Marking

Steels which have satisfactorily complied with the requirements specified in **310**, are to have the notation Z25 or Z35 after the material grade mark. (e.g. *EH36 Z25*, *EH36 Z35*)

### 311. YP47 Steels

#### 1. Application

- (1) This requirements applies to the application of steel plates with thickness of over 50mm and not greater than 100mm and specified yield point of 460  $N/mm^2$  to longitudinal structural members in the upper deck region of container carriers (such as hatch side coaming, hatch coaming top and the attached longitudinals).
- (2) For YP47 steels outside scope of the said thickness range, special consideration is to be given by the Society. And special consideration is to be given to the application of YP47 steels for other hull structures. (2021)
- (3) The requirements other than those specified in 311. are applicable to the requirements in 301.
- (4) Brittle crack arrest steels are to be met the additional brittle crack arrest requirements and properties defined in 312.. (2021)

#### 2. Kinds

The steels are classified as specified in **Table 2.1.42.**

#### 3. Heat treatment

The Heat treatment of steels is classified as specified in **Table 2.1.42.**

#### 4. Chemical composition

The Chemical composition of steels is classified as specified in **Table 2.1.42.**

**Table 2.1.42 Grade and Chemical compositions (2021)**

Grade	Deoxidati on practice	Chemical composition(%) <sup>(1)(2)</sup>														
		C	Si	Mn	P	S	Ni	Cr	Cu	Mo	Al <sup>(3)(4)</sup>	Nb <sup>(4)(5)</sup>	V <sup>(4)(5)</sup>	Ti <sup>(5)</sup>	C <sub>eq</sub> <sup>(6)</sup>	P <sub>cm</sub> <sup>(7)</sup>
EH47-H	Killed and Fine grain treated	0.18 max.	0.55 max.	0.90 ~ 2.00	0.020 max.	0.020 max.	1.0 max.	0.25 max.	0.35 max.	0.08 max.	0.015 min.	0.02 ~ 0.05	0.05 ~ 0.10	0.02 max.	0.49 max.	0.22 max.

Note

- (1) Where additions of any other element have been made as part of the steelmaking practice subject to approval by the Society, the content is to be indicated on product inspection certificate.
- (2) Variations in the specified chemical composition may be allowed subject to approval of Society.
- (3) The total aluminium content may be determined instead of the acid soluble content. In such cases the total aluminium content is to be not less than 0.020%.
- (4) The steel is to contain aluminium, niobium, vanadium or other suitable grain refining elements, either singly or in any combination. When used singly the steel is to contain the specified minimum content of the grain refining element. When used in combination, the specified minimum content of a fine graining element is not applicable.
- (5) The total niobium, vanadium and titanium content is not to exceed 0.12%.
- (6) The carbon equivalent C<sub>eq</sub> value is to be calculated from the ladle analysis using the following formula:  

$$C_{eq} = C + \frac{Mn}{6} + \frac{Cr + Mo + V}{5} + \frac{Ni + Cu}{15} (\%)$$
- (7) Cold cracking susceptibility P<sub>cm</sub> value is to be calculated using the following formula:  

$$P_{cm} = C + \frac{Si}{30} + \frac{Mn}{20} + \frac{Cu}{20} + \frac{Ni}{60} + \frac{Cr}{20} + \frac{Mo}{15} + \frac{V}{10} + 5B (\%)$$

#### 5. Mechanical properties

The Mechanical properties of steels are classified as specified in **Table 2.1.43.**

Table 2.1.43 Conditions of supply and mechanical properties

Grade	Mechanical Properties			Test Temp. (°C)	Impact test			Supply condition
	Yield Strength (N/mm <sup>2</sup> )	Tensile Strength (N/mm <sup>2</sup> )	Elongation (%)		Average Impact Energy(J)			
					L			
				50<math>t^{(1)} \le 70</math>	70<math>t^{(1)} \le 85</math>	85<math>t^{(1)} \le 100</math>		
EH47-H	460 min.	570~720	17 min.	-40	53 min.	64 min.	75 min.	TMCP <sup>(2)</sup>
Note (1) $t$ : thickness (mm) (2) Other conditions of supply are to be agreed by the Society.								

### 312. Brittle crack arrest steels (2021)

#### 1. Application

- (1) This requirements applies to the application of brittle crack arrest steels(EH36-BCA, EH40-BCA and EH47-H-BCA) with brittle crack arrest properties.
- (2) This requirements applies to the application of steels with thickness of over 50mm and not greater than 100 mm to longitudinal structural members in the upper deck region of container carriers (such as hatch side coaming, upper deck, etc.) specified in **Pt 7, Annex 7-8** of the Guidance.

#### 2. Definition

Brittle crack arrest steels are defined as steel plate with the specified brittle crack arrest properties measured by either the brittle crack arrest toughness  $K_{ca}$  or Crack Arrest Temperature (CAT).

#### 3. Chemical composition

The Chemical composition of steels is classified as specified in **Table 2.1.44**.

**Table 2.1.44 Grade and Chemical compositions**

Grade	Deoxidation practice	Chemical composition(%) <sup>(1)(2)</sup>														
		C	Si	Mn	P	S	Ni	Cr	Cu	Mo	Al <sup>(4)(5)</sup>	Nb <sup>(5)(6)</sup>	V <sup>(5)(6)</sup>	Ti <sup>(6)</sup>	C <sub>eq</sub> <sup>(7)</sup>	P <sub>cm</sub> <sup>(8)</sup>
<i>EH36-BCA</i>	Killed and Fine grain treated	0.18 max.	0.50 max.	0.90 ~ 2.00	0.020 max.	0.020 max.	2.0 max.	0.25 max.	0.50 max.	0.08 max.	0.015 min.	0.02 ~ 0.05	0.05 ~ 0.10	0.02 max.	0.47 max.	-
<i>EH40-BCA</i>		0.18 max.	0.50 max.	0.90 ~ 2.00	0.020 max.	0.020 max.	2.0 max.	0.25 max.	0.50 max.	0.08 max.	0.015 min.	0.02 ~ 0.05	0.05 ~ 0.10	0.02 max.	0.49 max.	
<i>EH47-H-BCA</i>		0.18 max.	0.55 max.	0.90 ~ 2.00	0.020 max.	0.020 max.	2.0 max.	0.50 max.	0.50 max.	0.08 max.	0.015 min.	0.02 ~ 0.05	0.05 ~ 0.10	0.02 max.	0.55 max.	

Note

- (1) Chemical composition of brittle crack arrest steels shall comply with this Table, regardless of chemical composition specified in **301.** and **311.**
- (2) Where additions of any other element have been made as part of the steelmaking practice subject to approval by the Society, the content is to be indicated on product inspection certificate.
- (3) Variations in the specified chemical composition may be allowed subject to approval of the Society.
- (4) The total aluminium content may be determined instead of the acid soluble content. In such cases the total aluminium content is to be not less than 0.020%.
- (5) The steel is to contain aluminium, niobium, vanadium or other suitable grain refining elements, either singly or in any combination. When used singly the steel is to contain the specified minimum content of the grain refining element. When used in combination, the specified minimum content of a fine graining element is not applicable.
- (6) The total niobium, vanadium and titanium content is not to exceed 0.12%.
- (7) The carbon equivalent C<sub>eq</sub> value is to be calculated from the ladle analysis using the following formula:  

$$C_{eq} = C + \frac{Mn}{6} + \frac{Cr + Mo + V}{5} + \frac{Ni + Cu}{15} (\%)$$
- (8) Cold cracking susceptibility P<sub>cm</sub> value is to be calculated using the following formula:  

$$P_{cm} = C + \frac{Si}{30} + \frac{Mn}{20} + \frac{Cu}{20} + \frac{Ni}{60} + \frac{Cr}{20} + \frac{Mo}{15} + \frac{V}{10} + 5B (\%)$$

#### 4. Brittle crack arrest properties

- (1) In addition to the required mechanical properties of 301. and 311., brittle crack arrest steels are to comply with the requirements specified in **Table 2.1.45**.
- (2) The brittle crack arrest properties specified in **Table 2.1.45** are to be evaluated for the products in accordance with the procedure approved by the Society. Test specimens are to be taken from each piece (means “the rolled product from a single slab or ingot if this is rolled directly into plates”), unless otherwise agreed by the Society.

**Table 2.1.45 Requirement of brittle crack arrest properties for brittle crack arrest steels**

Suffix to the steel grade <sup>(1)</sup>	Thickness range (mm)	Brittle crack arrest properties <sup>(2)(6)</sup>	
		Brittle crack arrest toughness $K_{ca}$ at $-10^{\circ}\text{C} (N/\text{mm}^{3/2})^{(3)}$	Crack Arrest Temperature CAT ( $^{\circ}\text{C}$ ) <sup>(4)</sup>
<i>BCA1</i>	$50 < t \leq 100$	6,000 min.	-10 or below
<i>BCA2</i>	$80 < t \leq 100$	8,000 min.	<sup>(5)</sup>

Note

- (1) Suffix “BCA1” or “BCA2” is to be affixed to the steel grade designation (e.g. *EH40-BCA1*, *EH47-H-BCA1*, *EH47-H-BCA2*, etc.).
- (2) Brittle crack arrest properties for brittle crack arrest steels are to be verified by either the brittle crack arrest toughness  $K_{ca}$  or Crack Arrest Temperature (CAT).
- (3)  $K_{ca}$  value is to be in accordance with the Guidance relating to the Rules specified by the Society. **【See Guidance】**
- (4) CAT is to be obtained in accordance with the Guidance relating to the Rules specified by the Society. **【See Guidance】**
- (5) Criterion of CAT for brittle crack arrest steels corresponding to  $K_{ca}=8,000 N/\text{mm}^{3/2}$  is to be approved by the Society
- (6) Where small-scale tests are used for product testing (batch release testing), these test methods are to be approved by the Society in accordance with the Guidance relating to the Rules specified. (2024) **【See Guidance】**

#### 5. Marking

For steels having brittle crack arrest properties to which the requirements given in 4. have been applied, the “brittle crack arrest *BCA*” is to be suffixed to the marking. (e.g. *EH47-H-BCA1*)

## Section 4 Steel Tubes and Pipes

### 401. Steel tubes for boilers and heat exchangers

#### 1. Application

- (1) The requirements are mainly to apply to steel tubes intended for heat transfer at inside or outside of the tubes; for example, smoke tubes, water tubes, stay tubes, superheater tubes of boilers, other tubes for high temperature heat exchangers, etc. (hereinafter referred to as "steel tubes").
- (2) Steel tubes other than those specified in (1) are to comply with the requirements in **101. 2.**

#### 2. Kinds

The steel tubes are classified as specified in **Table 2.1.46.**

**Table 2.1.46 Kinds**

Description	Grade
Carbon steel tubes for boilers and heat exchangers	<i>RSTH35</i> <i>RSTH42</i> <i>RSTH52</i>
Alloy steel tubes for boilers and heat exchangers	<i>RSTH12</i> <i>RSTH22</i> <i>RSTH23</i> <i>RSTH24</i>

#### 3. Heat treatment

The heat treatment of steel tubes is to comply with the requirements given in **Table 2.1.47.**

**Table 2.1.47 Heat treatment [See Guidance]**

Grade	Seamless steel tube		Electric-resistance welded steel tube		
	Hot working	Cold working	As weld	Hot working	Cold working
<i>RSTH 35</i>	As drawn	Low temperature annealed, Normalized or full annealed	Normalized	As drawn	Normalized <sup>(1)</sup>
<i>RSTH 42</i>				Low temperature annealed	
<i>RSTH 52</i>	Normalized				
<i>RSTH 12</i>	Low temperature annealed, Isothermal annealed, Full annealed, Normalized or Normalized and tempered <sup>(2)</sup>				
<i>RSTH 22</i>	Low temperature annealed, Isothermal annealed, Full annealed or Normalized and tempered <sup>(2)</sup>				
<i>RSTH 23</i> <i>RSTH 24</i>	Isothermal annealed, Full annealed or Normalized and tempered at 650°C and over		-		
NOTES (1) Steel tubes which are normalized prior to cold working may be finished by annealing (2) Low temperature annealing is not to be applied to electric resistance welded steel tube					

#### 4. Chemical composition

The chemical composition of steel tubes is to comply with the requirements given in **Table 2.1.48.**  
**[See Guidance]**

Table 2.1.48 Chemical Composition

Grade	Chemical composition (%)						
	C	Si	Mn	P	S	Cr	Mo
<i>RSTH35</i>	0.18 max.	0.10~0.35	0.30~0.60	0.035 max.	0.035 max.	-	-
<i>RSTH42</i>	0.32 max.		0.30~0.80				
<i>RSTH52</i>	0.25 max.		1.00~1.50				
<i>RSTH12</i>	0.10~0.20	0.10~0.50	0.30~0.80	0.030 max.	0.030 max.	0.80~1.25	0.45~0.65
<i>RSTH22</i>	0.15 max.	0.50 max.	0.30~0.60				
<i>RSTH23</i>		0.50~1.00					
<i>RSTH24</i>		0.50 max.					

NOTE:  
In case where approved by the Society, *RSTH35* and *RSTH42* may be the killed steel of below 0.10% Si.

### 5. Mechanical properties [See Guidance]

The mechanical properties of steel tubes are to comply with the following requirements.

(1) Tensile test : The tensile test of steel tubes is to comply with the requirements given in **Table 2.1.49**.

Table 2.1.49 Mechanical Properties

Grade	Yield strength (N/mm <sup>2</sup> )	Tensile strength (N/mm <sup>2</sup> )	Elongation (%) ( $L = 5.65\sqrt{A}$ )
<i>RSTH35</i>	175 min.	340 min.	26 (22) min.
<i>RSTH42</i>	255 min.	410 min.	21 (17) min.
<i>RSTH52</i>	295 min.	510 min.	
<i>RSTH12</i>	205 min.	380 min.	
<i>RSTH22</i> <i>RSTH23</i> <i>RSTH24</i>		410 min.	

NOTES:  
1. The values of elongation in parenthesis are applicable to the test specimens taken transversely. In this case, the sampling material is to be heated 600°C to 650°C after flattened and annealed in order to make it free from strain.  
2. In case where test specimen of non-tubular section is taken from an electric-resistance welded steel tube, the test specimen is to be taken from the parts that do not include the welded line.

(2) *Flattening test* : A tubular section which is taken from the end of the steel tube is to stand being flattened cold between parallel plates, without cracking or showing flaw, until the distance between the plates becomes less than the value of H calculated by the following formula. In this case, the length L of steel tube is to be not less than 50 mm, however, not more than 100 mm. For electric-resistance welded steel tubes, however, the welded line is to be placed at right angle to the direction of the applied force as shown in **Fig 2.1.10 (a)** For tubes, however, of 15% of outside diameter and over in thickness, C-type test specimen may be used, having a part of its circumference discarded as shown in **Fig 2.1.10 (b)**

$$H = \frac{(1+e)t}{e + \frac{t}{D}}$$

where:

$H$  = Distance between flattening plates (mm).

$t$  = Thickness of steel tube (mm).

$D$  = Outside diameter of steel tube (mm).

$e$  = Constant given in **Table 2.1.50** which varies according to the grade of steel tubes.

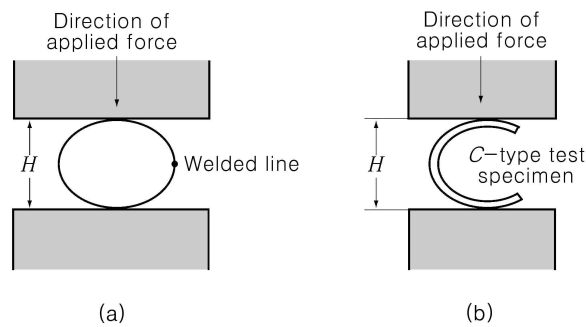


Fig 2.1.10 Flattening test

Table 2.1.50 Value of  $e$

Grade	Value of $e$
<i>RSTH35</i>	0.09
<i>RSTH42, RSTH12, RSTH22, RSTH23, RSTH24</i>	0.08
<i>RSTH52</i>	0.07

- (3) *Flaring test* : A section of steel tube which is taken from its end is to stand being flared cold with a tool having an included angle of 60 degrees, until the steel tube at the mouth of the flare is expanded without cracking or showing flaw to the diameter shown in **Table 2.1.51**. The rate of penetration of the mandrel shall not exceed 50 mm/min. In this case, the length of test specimen is to be  $1.5D$ , however, not less than 50 mm.

Table 2.1.51 Outside Diameter of Steel Tube End after Flaring

Grade	Outside diameter of steel tube end
<i>RSTH35, RSTH42, RSTH52</i>	1.2 times the outside diameter of steel tube
<i>RSTH12, RSTH22, RSTH23, RSTH24</i>	1.14 times the outside diameter of steel tube

- (4) *Reverse flattening test* : A section of steel tube of 100 mm in length which is taken from the steel tube is to be slotted longitudinally on the opposite side of the welded line, opened and flattened without cracking or showing flaw on the inside of the welded line. There is also to be no misalignment, lack of penetration and overlap. But, this test is applied for electric-resistance welded steel tubes only.

## 6. Hydraulic test

- (1) Steel tubes are to be hydraulically tested to a satisfactory result by 2 times and over the maximum working pressure at the mill. But the minimum test pressure is to be 7 MPa.
- (2) The test pressure prescribed in (1) need not exceed the pressure calculated by the following formula:



$$P = \frac{2.0St}{D} \text{ (Mpa)}$$

where:

$t$  = Thickness of steel tube (mm)

$D$  = Outside diameter of steel tube (mm)

$s$  = 60 % of the prescribed minimum yield strength (N/mm<sup>2</sup>)

- (3) Where each steel tube is hydraulically tested as a regular procedure during the process of manufacturing at the mill, which makes a number of steel tubes continually, and the results are forwarded to the Surveyor, the test in the presence of the Surveyor may be dispensed with.
- (4) A non-destructive inspection deemed appropriate by the Society may be substituted for the hydraulic test specified in (1). **【See Guidance】**

### 7. Selection of test specimen **【See Guidance】**

The test specimens are to be taken in accordance with the following requirements, from each grade and each size which has been heat treated at the same time in the same heating furnace for heat-treated tubes and from each grade and each size for non-heat-treated steel tubes respectively.

(1) *Seamless steel tubes*

One sampling steel tube is to be selected from each lot of 50 tubes or fraction thereof and each one specimen for tensile test, flattening test and flaring test is to be taken from each sampling steel tube.

(2) *Electric-resistance welded steel tubes*

For electric-resistance welded steel tubes, in addition to the requirements in (1), one sampling steel tube is to be selected from each lot of 100 tubes or fraction thereof, and one reverse flattening test specimen is to be taken from each of the sampling steel tubes.

### 8. Tolerance for dimensions

The tolerances for the outside diameter and thickness are to comply with the requirements in **Table 2.1.52** and **Table 2.1.53** respectively.

**Table 2.1.52 Tolerance for Outside Diameter of steel Tubes**

Outside diameter of steel tube $D$ (mm)	Tolerance for Outside Diameter (mm)			
	Seamless steel tube		Electric-resistance welded steel tube	
	Hot finished	Cold working	Other than cold working	Cold working
$D < 25$	+ 0.4 - 0.8	± 0.10	± 0.15	± 0.10
$25 \leq D < 40$		± 0.15	± 0.20	± 0.15
$40 \leq D < 50$		± 0.20	± 0.25	± 0.20
$50 \leq D < 60$		± 0.25	± 0.30	± 0.25
$60 \leq D < 80$		± 0.30	± 0.40	± 0.30
$80 \leq D < 100$	+ 0.4 - 1.2	± 0.40	+ 0.40 - 0.60	± 0.40
$100 \leq D < 120$		+ 0.40 - 0.60	+ 0.40 - 0.80	+ 0.40 - 0.60
$120 \leq D < 160$		+ 0.40 - 0.80	+ 0.40 - 1.00	+ 0.40 - 0.80
$160 \leq D < 200$	+ 0.4 - 1.6	+ 0.40 - 1.20	+ 0.40 - 1.20	+ 0.40 - 1.20
$200 \leq D$	+ 0.4 - 1.8	+ 0.40 - 1.60	+ 0.40 - 1.60	+ 0.40 - 1.60

Table 2.1.53 Tolerance for thickness

Kind	Thickness $t$ (mm)					
	Outside diameter $D$ (mm)	$t < 2$	$2 \leq t < 2.4$	$2.4 \leq t < 3.8$	$3.8 \leq t < 4.6$	$4.6 \leq t$
Hot finished seamless steel tube	$D < 100$	-	+40 % 0 %	+35 % 0 %	+33 % 0 %	+28 % 0 %
	$D \geq 100$		-			
Cold drawn seamless steel tube and Electric-resistance welded steel tube of cold working	$D < 40$	+0.4mm 0 mm	+22 % 0 %			
	$D \geq 40$	+22 %, 0 %				
Electric-resistance welded steel tube of other than cold working	$D < 40$	+0.3mm 0 mm	+18 % 0 %			
	$D \geq 40$	+18 %, 0 %				

NOTE:  
For hot finished seamless steel tubes, the tolerance for deviation in wall thickness is to be 22.8% and under of the thickness of the steel tube. But, for steel tubes of less than 5.6 mm in thickness, this note is not applied.

### 9. Quality

- (1) Each steel tubes are hydraulically or non-destructively tested as a regular procedure during the process of manufacturing at the mill and are free from leakages or harmful defects.
- (2) The steel tubes are to be of uniform quality. For electric-resistance welded steel tubes, deposit metal projected on outside of tubes is to be removed and finished smooth and that projected on inside of tubes is to be removed to have a height not more than 0.25 mm.

### 10. Retest procedures

Where the tensile test, *flattening test*, *flaring test* or *reverse flattening test* fails to meet the requirements, additional tests may be conducted according to the requirements given in 109.

### 11. Marking

- (1) The name or brand of the manufacturer, grade of tubes, size and symbol of the method of the manufacture relating to (2) below are to be legibly stamped or stenciled before shipment on each length steel tube in case of 30 mm and above in outside diameter and on each bundle or container of steel tubes in case of less than 30 mm in outside diameter. The Society's brand indicating compliance with the requirements is to be stamped in the vicinity of the foregoing marks.
- (2) The symbols indicating the method of manufacture are to be as specified in the following:  
 Hot finished seamless steel tube ..... -S-H  
 Cold drawn seamless steel tube ..... -S-C  
 Electric-resistance welded steel tube of other than hot and cold working ..... -E-G  
 Electric-resistance welded steel tube of hot working ..... -E-H  
 Electric-resistance welded steel tube of cold working ..... -E-C

## 402. Steel pipes for pressure piping

### 1. Application

- (1) These requirements are mainly to apply to seamless steel pipes and electric-resistance welded steel pipes intended for use in piping which is prescribed in Pt 5, Ch 6 (hereinafter referred to as "steel pipes").
- (2) Steel pipes for general purpose specified in 102. 2 (4) of Pt 5, Ch 6 are to comply with the requirements of KS D 3507(SPP) or equivalent thereto. However, tests in the presence of the Surveyor are not required.
- (3) The steel pipes having characteristics differing from those specified in 402. are to comply with the requirements in 101. 2.

## 2. Kinds

The steel pipes are classified as specified in **Table 2.1.54**.

**Table 2.1.54 Grades of Steel Pipes**

Kind	Grade	Schedule applied
Grade 1 Carbon steel pipe for pressure service	<i>RST138</i> <i>RST142</i>	Sch.10~Sch.80
Grade 2 Carbon steel pipe for high pressure service	<i>RST238</i> <i>RST242</i> <i>RST249</i>	Sch.40~Sch.160
Grade 3 Carbon steel pipe for high temperature service	<i>RST338</i> <i>RST342</i> <i>RST349</i>	Sch.10~Sch.160
Grade 4 Alloy steel pipe	<i>RST412</i> <i>RST422</i> <i>RST423</i> <i>RST424</i>	

## 3. Heat treatment

The heat treatment of steel pipes is to comply with the requirements given in **Table 2.1.55**.

**Table 2.1.55 Heat treatment**

Grade		Seamless steel pipe		Electric-resistance welded steel pipe		
		Hot finished	Cold drawn	As drawn	Hot finished	Cold finished
Grade1	<i>RST138</i> <i>RST142</i>	As drawn <sup>(1)</sup>	Annealed	As drawn	As drawn	Annealed
Grade2	<i>RST238</i>		Low temperature annealed or Normalized	-		
	<i>RST242</i> <i>RST249</i>					
Grade3	<i>RST338</i> <i>RST342</i>	As drawn <sup>(1)</sup>	Low temperature annealed or Normalized	Low temperature annealed or Normalized	As drawn	Low temperature annealed or Normalized
	<i>RST349</i>			-		
Grade4	<i>RST412</i>	Low temperature annealed Isothermal annealed, Full annealed, Normalized or Normalized and tempered				
	<i>RST422</i>	Low temperature annealed , Isothermal annealed, Full annealed or Normalized and tempered				
	<i>RST423</i> <i>RST424</i>	Isothermal annealed, Full annealed or Normalized and tempered at 650°C and over				

NOTE:

(1) In the case of Grade 2 & Grade 3, low temperature annealed or normalized may be applied if necessary. (2021)

#### 4. Chemical composition

The chemical composition of steel pipes is to comply with the requirements given in **Table 2.1.56**.

**Table 2.1.56 Chemical Composition**

Grade		Chemical composition (%)						
		<i>C</i>	<i>Si</i>	<i>Mn</i>	<i>P</i>	<i>S</i>	<i>Cr</i>	<i>Mo</i>
Grade 1	<i>RST138</i>	0.25 max.	0.35 max.	0.30~0.90	0.040 max.	0.040 max.		
	<i>RST142</i>	0.30 max.		0.30~1.00				
Grade 2	<i>RST238</i>	0.25 max.	0.10~0.35	0.30~1.10	0.035 max.	0.035 max.	-	-
	<i>RST242</i>	0.30 max.		0.30~1.40				
	<i>RST249</i>	0.33 max.		0.30~1.50				
Grade 3	<i>RST338</i>	0.25 max.		0.30~0.90				
	<i>RST342</i>	0.30 max.		0.30~1.00				
	<i>RST349</i>	0.33 max.						
Grade 4	<i>RST412</i>	0.10~0.20	0.10~0.50	0.30~0.80	0.030 max.	0.030 max.	0.80~1.25	0.45~0.65
	<i>RST422</i>	0.15 max.	0.50 max.	0.30~0.60			1.00~1.50	
	<i>RST423</i>		0.50~1.00				1.90~2.60	0.87~1.13
	<i>RST424</i>		0.50 max.					

#### 5. Mechanical properties

The mechanical properties of steel pipes are to comply with the following requirements.

(1) *Tensile test* : The tensile test of steel pipes are to comply with the requirements given in **Table 2.1.57**.

**Table 2.1.57 Mechanical Properties**

Grade		Yield strength (N/mm <sup>2</sup> )	Tensile strength (N/mm <sup>2</sup> )	Elongation (%) ( $L = 5.65\sqrt{A}$ )
Grade 1 Grade 2 Grade 3	<i>RST138</i> <i>RST238</i> <i>RST338</i>	215 min.	370 min.	24 (20) min.
Grade 1 Grade 2 Grade 3	<i>RST142</i> <i>RST242</i> <i>RST342</i>	245 min.	410 min.	21 (17) min.
Grade 2 Grade 3	<i>RST249</i> <i>RST349</i>	275 min.	480 min.	19 (15) min.
Grade 4	<i>RST412</i>	205 min.	380 min.	21(17) min.
Grade 4	<i>RST422</i> <i>RST423</i> <i>RST424</i>		410 min.	

**NOTES:**

- The requirements for elongation given in parentheses in the Table are applied for the case where test specimens are taken transversely. In this case, the test sample is to be stress relieved at the temperature of 600°C to 650°C after flattened.
- In case where test specimen of non-tubular section is taken from electric-resistance welded steel pipes, the test specimen is to be taken from the part that does not include a welded line.

(2) *Flattening test*

(a) *Pipes other than Grade 1 of electric-resistance welded steel pipe:* A tubular section of steel pipe which is taken from the end of the steel pipe, is to stand being flattened between parallel plates, without cracking or showing flaw, until the distance between the plates becomes less than the value of  $H$  calculated by the following formula. In this case, the length of test specimen is to comply with the requirements in **401.5** (2). For steel pipes, however, of 15% of outside diameter and above in thickness, C-type test specimen may be used, having a part of its circumference discarded as shown in **Fig 2.1.9 (b)**

$$H = \frac{(1+e)t}{e + \frac{t}{D}}$$

where:

$H$  = Distance between flattening plates (mm).

$t$  = Thickness of steel pipe (mm).

$D$  = Outside diameter of steel pipe (mm).

$e$  = Constant given in **Table 2.1.58** which varies according to the grade of steel tubes.

**Table 2.1.58** value of  $e$

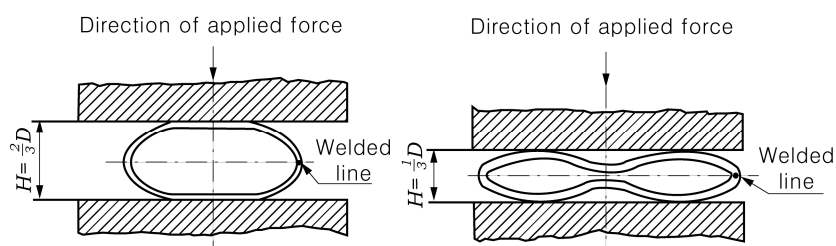
Grade	RST 142, RST 242, RST 249, RST 342 RST 349	RST 138, RST 238, RST 338, RST 412 RST 422, RST 423, RST 424
$e$	0.07	0.08

(b) *Electric-resistance welded steel pipes Grade 1 :*

$$H = \frac{2}{3}D \text{ for welded line,}$$

$$H = \frac{1}{3}D \text{ for elsewhere.}$$

In case of electric-resistance welded steel pipes, the welded line is to be placed at right angle to the direction of the applied force, as in **Fig 2.1.11**.



**Fig 2.1.11** Flattening test of electric-resistance welded steel pipes Grade 1

- (3) *Bend test :* For steel pipes of 50 mm and under in outside diameter, the specimen for flattening test may be substituted for that for bend test. In this case, a test specimen of tubular section which is taken from the end of the steel pipe and has sufficient length is to stand being bent cold, up to the specified value in **Table 2.1.59**, without cracking or showing flaw on the wall. But, for Grade 4, this test need not be carried out.
- (4) In the case of steel pipes in accordance with **Pt 7, Ch 5, Sec 17, 1712**.(Special requirements for ammonia) of the Rules, the specified value of the maximum yield stress or proof stress may be limited after approval by the Society. (2023)

Table 2.1.59 Bend Test

Grade	Angle of bending	Inside bend radius
1, 2 and 3	90°	6 times the outside diameter of steel pipe
NOTE: Electric-resistance welded steel pipes are to be so bent as the welded line is placed widest.		

## 6. Hydraulic test

- (1) Grade 1 steel pipes are to be hydraulically tested with the pressure specified in **Table 2.1.60**.
- (2) In case where the test pressure higher than prescribed in (1) is specified by the purchaser for Grade 2 through 4 steel pipes, the test is to be carried out with the specified pressure. In this case, test pressure need not exceed the pressure calculated by the following formula:

$$P = \frac{2.0St}{D} (\text{MPa})$$

where :

$P$  = Hydraulic test pressure (MPa).

$D$  = Outside diameter of steel pipe (mm).

$t$  = Thickness of steel pipe (mm).

$S$  = 60 % of the prescribed minimum yield strength (N/mm<sup>2</sup>).

- (3) When each steel pipe is hydraulically tested as a regular procedure during the process of manufacturing at the mill which makes a number of steel tubes continually, and the results are forwarded to the Surveyor, the test in the presence of the Surveyor may be dispensed with.
- (4) A non-destructive inspection deemed appropriate by the Society may be substituted for the hydraulic inspection specified in (1). **[See Guidance]**

## 7. Selection of test specimen

- (1) *Grade 1* : Sampling steel pipes are to be selected as following requirements in connection with the nominal diameter of steel pipes specified in **Table 2.1.58** and each one specimen for tensile test, flattening test or bend test is to be taken from each sampling steel pipe.
  - (a) *For steel pipes less than 65A in nominal diameter* : One sampling steel pipe is to be selected from each lot of 1000 pipes or fraction thereof.
  - (b) *For steel pipes which a nominal diameter is 65A or above and less than 150A* : One sampling steel pipe is to be selected from each lot of 500 pipes or fraction thereof.
  - (c) *For steel pipes which a nominal diameter is 150A or above and less than 350A* : One sampling steel pipe is to be selected from each lot of 250 pipes or fraction thereof.
  - (d) *For steel pipes more than 350A in nominal diameter* : One sampling steel pipe is to be selected from each lot of 150 pipes or fraction thereof.
- (2) *Grade 2* : One sampling steel pipe is to be selected from each lot of 50 pipes or fraction thereof, and each one specimen for tensile test and flattening test or bend test is to be taken from each sampling steel pipe.
- (3) *Grade 3*  
Selection of test specimen is to comply with the requirements in (2).
- (4) *Grade 4* : One sampling steel pipe is to be selected from each lot of 50 pipes or fraction thereof, and each one specimen for tensile test and flattening test or bend test is to be taken from each sampling steel pipe.

Table 2.1.60 Schedule and Hydraulic Test Pressure

Nominal diameter (A)	Outside diameter (mm)	Nominal thickness (mm)									
		Sch.10 (10S)	Sch.20 (20S)	Sch.30	Sch.40	Sch.60	Sch.80	Sch.100	Sch.120	Sch.140	Sch.160
6	10.5	(1.2)	(1.5)	-	1.7	2.2	2.4	-	-	-	-
8	13.8	(1.65)	(2.0)	-	2.2	2.4	3.0	-	-	-	-
10	17.3	(1.65)	(2.0)	-	2.3	2.8	3.2	-	-	-	-
15	21.7	(2.1)	(2.5)	-	2.8	3.2	3.7	-	-	-	4.7
20	27.2	(2.1)	(2.5)	-	2.9	3.4	3.9	-	-	-	5.5
25	34.0	(2.8)	(3.0)	-	3.4	3.9	4.5	-	-	-	6.4
32	42.7	(2.8)	(3.0)	-	3.6	4.5	4.9	-	-	-	6.4
40	48.6	(2.8)	(3.0)	-	3.7	4.5	5.1	-	-	-	7.1
50	60.5	(2.8)	3.2(3.5)	-	3.9	4.9	5.5	-	-	-	8.7
65	76.3	(3.0)	4.5(3.5)	-	5.2	6.0	7.0	-	-	-	9.5
80	89.1	(3.0)	4.5(4.0)	-	5.5	6.6	7.6	-	-	-	11.1
90	101.6	(3.0)	4.5(4.0)	-	5.7	7.0	8.1	-	-	-	12.7
100	114.3	(3.0)	4.9(4.0)	-	6.0	7.1	8.6	-	11.1	-	13.5
125	139.8	(3.4)	5.1(5.0)	-	6.6	8.1	9.5	-	12.7	-	15.9
150	165.2	(3.4)	5.5(5.0)	-	7.1	9.3	11.0	-	14.3	-	18.2
200	216.3	(4.0)	6.4(6.5)	7.0	8.2	10.3	12.7	15.1	18.2	20.6	23.0
250	267.5	(4.0)	6.4(6.5)	7.8	9.3	12.7	15.1	18.1	21.4	25.4	28.6
300	318.5	(4.5)	6.4(6.5)	8.4	10.3	14.3	17.4	21.4	25.4	28.6	33.3
350	355.6	6.4	7.9	9.5	11.1	15.1	19.0	23.8	27.8	31.8	35.7
400	406.4	6.4	7.9	9.5	12.7	16.7	21.4	26.2	30.9	36.5	40.5
450	457.2	6.4	7.9	11.1	14.3	19.0	23.8	29.4	34.9	39.7	45.2
500	508.0	6.4	9.5	12.7	15.1	20.6	26.2	32.5	38.1	44.4	50.0
550	558.8	6.4	9.5	12.7	15.9	22.2	28.6	34.9	41.3	47.6	54.0
600	609.4	6.4	9.5	14.3	17.5	24.6	31.0	38.9	46.0	52.4	59.5
650	660.4	7.9	12.7	-	18.9	26.4	34.0	41.6	49.1	56.6	64.2
Hydraulic test pressure (MPa)	Grade 1	2.0	3.5	5.0	6.0	9.0	12.0	-	-	-	-
	Grade 2	-	-	-	6.0	9.0	12.0	15.0	18.0	20.0	20.0
	Grade 3 and Grade 4	2.0	3.5	5.0	6.0	9.0	12.0	15.0	18.0	20.0	20.0

NOTE:  
The values of nominal thickness in parentheses are applicable to stainless steel pipes.

## 8. Tolerance for dimensions

Tolerances for the outside diameter and the thickness are to comply with the requirements in **Table 2.1.61**.

**Table 2.1.61 Tolerance for Dimensions**

Kind	Outside diameter of steel pipe D (mm)	Tolerance for outside diameter	Tolerance for wall thickness			
			Grade 1		Grade 2, 3 and 4	
Hot finished seam-less steel pipe	D < 50	± 0.5 mm	Thickness of steel pipe: Less than 4 mm	+ 0.6 mm - 0.5 mm	Thickness of steel pipe: Less than 4 mm	± 0.5 mm
	D ≥ 50	± 1 %	Thickness of steel pipe: 4 mm and over	+ 15 % - 12.5 %	Thickness of steel pipe: 4 mm and over	± 12.5 %
Cold drawn seam-less steel pipe and electric-resistance welded steel pipe	D < 40	± 0.3 mm	Thickness of steel pipe: Less than 3 mm	± 0.3 mm	Thickness of steel pipe: Less than 2 mm	± 0.2 mm
	D ≥ 40	± 0.80 mm	Thickness of steel pipe: 3 mm and over	± 10 %	Thickness of steel pipe: 2 mm and over	± 10 %

NOTE:  
For hot finished seamless steel pipes Grades 2, 3 and 4, the tolerance for deviation in wall thickness is to be 20 % and under of the thickness of the pipes. But, for steel pipes less than 5.6 mm in thickness, this note is not applied.

## 9. Quality

- (1) Each steel pipes are hydraulically or non-destructively tested and are free from leakages or harmful defects.
- (2) The steel pipes are to be of uniform quality and free from harmful defects.

## 10. Retest procedures

Where the tensile test, *flattening test* or bend *test* fails to meet the requirements, additional tests may be conducted according to the requirements given in **109**.

## 11. Marking

- (1) The name or brand of the manufacturer, grade of steel tubes, size and symbol of the method of the manufacture relating to (2) below are to be legibly stamped or stenciled before shipment on each length steel tube in case of 60 mm and above in outside diameter and on each bundle or container of steel tubes in case of less than 60 mm in outside diameter. The Society's brand indicating compliance with the requirements is to be in the vicinity of the foregoing marks.
- (2) The symbols indicating the method of manufacture are to comply with the requirement in **401.11** (2).
- (3) For steel pipes to which the requirements given in **5**. (4), the specified value of the maximum yield stress or proof stress and "A" are to be suffixed to the markings. (e.g. *RST138-440A*) (2023)

## 403. Stainless steel pipes

### 1. Application

- (1) The requirements are to apply to the stainless steel pipes for low temperature service or corrosion-resistance service (hereinafter referred to as "stainless steel pipes").
- (2) Duplex stainless steel pipes are to be as in accordance with the Guidance relating to the Rules



- specified by the Society. (2018) **【See Guidance】**  
 (3) Stainless steel pipes having characteristics differing from those specified in **403**, are to comply with the requirements in **101. 2**.

## 2. Kinds

The stainless steel pipes are classified as specified in **Table 2.1.62**.

**Table 2.1.62 Grades and Chemical Composition (2020) (2022)**

Grade	solid solution treatment(°C)	Chemical Composition (%)										
		C	Si	Mn	P	S	Ni	Cr	Mo	Others		
RSTS 304TP	1010 and over, quenching	0.080 max.	1.00 max.	2.00 max.	0.040 max.	0.030 max.	8.00~11.00	18.00~20.00	-	-		
RSTS 304LTP	1010 and over, quenching	0.030 max.					8.00~13.00					
RSTS 309STP	1030 and over, quenching	0.080 max.	1.50 max.				12.00~15.00	22.00~24.00				
RSTS 310STP	1030 and over, quenching						19.00~22.00	24.00~26.00				
RSTS 316TP	1010 and over, quenching	0.030 max.	1.00 max.				10.00~14.00	16.00~18.00			2.00~3.00	
RSTS 316LTP	1010 and over, quenching						10.00~16.00					
RSTS 317TP	1010 and over, quenching	0.080 max.					11.00~15.00	18.00~20.00			3.00~4.00	
RSTS 317LTP	1010 and over, quenching	0.030 max.					9.00~13.00	17.00~19.00			-	Ti ≥ 5× C
RSTS 321TP	920 and over, quenching	0.080 max.										Nb ≥ 10 × C
RSTS 347TP	980 and over, quenching	0.080 max.					1.00 max.	2.00 max.			0.040 max.	0.030 max.

## 3. Heat treatment

The stainless steel pipes are generally to receive a solid solution treatment. For RSTS 321TP and RSTS 347TP, stabilizing treatment may be required. In this case, heat treatment temperature is to be of 850~930°C.

## 4. Chemical composition

The chemical composition of stainless steel pipes is to comply with the requirements given in **Table 2.1.62**.

## 5. Mechanical properties

- (1) The mechanical properties of stainless steel pipes are to comply with the following requirements.
- Tensile test*  
The tensile test of stainless steel pipes is to comply with the requirements given in **Table 2.1.63**.
  - Flattening test*  
Flattening tests are to be carried out in accordance with the requirements in **402. 5 (2)**. However, where the requirements are applied, the value of e is to be taken as 0.09.
  - Guided Bend test*  
For welded steel pipes of 200A and over, the flattening test may be substituted for that for

guided bend test. (2019)

- (2) The Society may require the impact test or corrosion resistance test according to purposes of stainless steel pipes.

**Table 2.1.63 Tensile Test**

Grade	Yield strength (N/mm <sup>2</sup> )	Tensile strength (N/mm <sup>2</sup> )	Elongation (%) ( $L = 5.65\sqrt{A}$ )	
			L	T
<i>RSTS304TP</i>	205 min.	520 min.	26 min.	22 min.
<i>RSTS304LTP</i>	175 min.	480 min.		
<i>RSTS309STP</i>	205 min.	520 min.		
<i>RSTS310STP</i>				
<i>RSTS316TP</i>				
<i>RSTS316LTP</i>	175 min.	480 min.		
<i>RSTS317TP</i>	205 min.	520 min.		
<i>RSTS317LTP</i>	175 min.	480 min.		
<i>RSTS321TP</i>	205 min.	520 min.		
<i>RSTS347TP</i>				

NOTES:

1. *L* (or *T*) denotes that the longitudinal axis of the test specimen is arranged parallel (or normal) to the final direction of rolling.
2. Where the nominal diameter of stainless steel pipes is 200 mm and over, tensile test specimens may be taken transversely.
3. Where test specimens of non-tubular section are taken from welded pipes, the test specimens are to be taken from the part that does not include the welded line.

## 6. Hydraulic test

- (1) Stainless steel pipes are to be hydraulically tested with the pressure specified in **Table 2.1.64**.

**Table 2.1.64 Hydraulic Test Pressure**

Schedule No.	Sch.10S	Sch.20S	Sch.40	Sch.80	Sch.120	Sch.160
Test pressure (MPa)	2.0	3.5	6.0	12.0	18.0	20.0

- (2) In case where the test pressure higher than prescribed in (1) is specified by the purchaser, the test is to be carried out with the specified pressure. In this case, the test pressure need not exceed the pressure calculated by the following formula:

$$P = \frac{2.0S}{D} (\text{Mpa})$$

where:

*P* = Hydraulic test pressure (MPa).

*t* = Thickness of stainless steel pipe (mm).

*D* = Outside diameter of stainless steel pipe (mm).

*S* = 60 % of the prescribed minimum yield strength (N/mm<sup>2</sup>).

- (3) When each pipe is hydraulically tested as a regular during the process of manufacturing at the mill which makes a number of tubes continually, and the results are forwarded to the Surveyor, the test in the presence of the Surveyor may be dispensed with.

(4) A non-destructive inspection deemed appropriate by the Society may be substituted for the hydraulic test specified in (1).

### 7. Selection of test specimens

One sampling pipe is to be selected from each lot of 50 pipes or fraction thereof which are of the same charge, size and kind and are simultaneously heat treated, and each one specimen for tensile test and flattening test is to be taken from each sample pipe.

### 8. Tolerance for dimensions

Tolerances for the outside diameter and the thickness are to comply with the requirements in **Table 2.1.65**.

**Table 2.1.65 Tolerance for Dimensions**

Kind	Outside diameter of stainless steel pipe		Tolerance for wall thickness	
	Hot-finished seamless stainless steel pipe	Less than 50	± 0.5 mm	Thickness of pipe: Less than 4 mm
50 and over		± 1 %	Thickness of pipe: 4 mm and over	± 12.5 %
Cold drawn seamless stainless pipe, automatic arc welded stainless steel pipe and electric-resistance welded stainless steel pipe	Less than 30	± 0.3 mm	Thickness of pipe: Less than 2 mm	± 0.2 mm
	30mm and over	± 1 %	Thickness of pipe: 2 mm and over	± 10 %
<p>NOTE: For hot finished seamless stainless steel pipes, the tolerance for deviation in wall thickness is to be 20 % and under of the thickness of the pipes. But, for stainless steel pipes less than 5.6 mm in thickness, this note is not applied.</p>				

### 9. Quality

- (1) Each steel pipes are hydraulically or non-destructively tested and are free from leakages or harmful defects.
- (2) The stainless steel pipes are to be of uniform quality and free from harmful defects.

### 10. Retest procedures

Where the tensile test or *flattening test* fails to meet the requirements, additional tests may be conducted according to the requirements given in **109**.

### 11. Marking

Stainless steel pipes which have satisfactorily complied with the required tests are to be marked with identification mark in accordance with the requirements in **402. 10**. However, the symbols indicating the manufacturing method of automatic arc welded steel pipes are to be as specified in the following:

- Automatic arc welded steel pipe : -A
- Automatic arc welded and cold finished steel pipe : -A-C
- Automatic arc welded and machined steel pipe : -A-B

## 404. Steel pipes for low temperature service

### 1. Application

- (1) These requirements are to apply to the seamless steel pipes and electric resistance welded steel pipes not exceeding 25 mm in thickness, intended to be used at the design temperature lower than 0°C in liquefied gas carriers (hereinafter referred to as "steel pipes").

- (2) Any requirement regarding the steel pipes over 25 mm in thickness is left to the discretion of the Society. **【See Guidance】**  
 (3) Steel pipes having characteristics differing from those specified in **404**, are to comply with the requirements in **101. 2**.

## 2. Kinds

The steel pipes are classified as given in **Table 2.1.66**.

## 3. Deoxidation practice and chemical composition

The deoxidation practice and chemical composition of each grade are to comply with the requirements given in **Table 2.1.66**.

**Table 2.1.66 Grades and Chemical Composition (%)**

Grade	Deoxidation	C	Si	Mn	P	S	Ni
RLPA	Fully killed fine grain	0.23 max.	0.35 max.	1.60 max.	0.035 max.	0.035 max.	-
RLPB		0.18 max.	0.35 max.	1.60 max.	0.035 max.	0.035 max.	-
RLPC		0.18 max.	0.35 max.	1.60 max.	0.035 max.	0.035 max.	-
RLP2		0.19 max.	0.10~0.35	0.90 max.	0.035 max.	0.035 max.	2.00~2.60
RLP3		0.16 max.	0.10~0.35	0.90 max.	0.030 max.	0.030 max.	3.20~3.80
RLP9		0.10 max.	0.10~0.35	0.90 max.	0.030 max.	0.030 max.	8.40~9.50

## 4. Heat treatment

The heat treatment of steel pipes is to comply with the requirements given in **Table 2.1.67**.

## 5. Mechanical properties

- (1) The mechanical properties of steel pipes are to comply with the following (a) to (d).  
 (a) *Tensile test*  
 The tensile test of steel pipes is to comply with the requirements given in **Table 2.1.67**.  
 (b) *Impact test*  
 The impact test of steel pipes is to comply with the requirements given in **Table 2.1.67**.  
 (c) *Flattening test*  
 Flattening test is to be carried out in accordance with the requirements given in **402. 5 (2)**. Where this requirement is applied, the value of e is to be taken as 0.08. For steel pipes of 50 mm and under in outside diameter, the specimen for flattening test may be substituted for that for bend test. In this case, a test specimen of tubular section which is taken from the end of the steel pipe and has sufficient length is to stand being bent cold, up to the specified value in **Table 2.1.67**, without flaw and cracking on the outside of bent portion. Electric resistance welded steel pipes are to be bent at the place where the welded line is on the outside of bent portion.  
 (2) Where deemed necessary by the Society, other tests may be required in addition to the tests specified in (1)  
 (3) In the case of steel pipes in accordance with **Pt 7, Ch 5, Sec 17, 1712**.(Special requirements for ammonia) of the Rules, the specified value of the maximum yield stress or proof stress may be limited after approval by the Society. (2023)

## 6. Hydraulic test

All steel pipes are to be subjected to hydraulic test in accordance with the requirements given in **402. 6**.

## 7. Selection of test specimens

- (1) One sampling pipe is to be selected from each lot of 50 pipes or fraction thereof which are of

the same charge, size and kind and are simultaneously heat treated. Each one specimen for tensile test and flattening test is to be taken from each sample pipe.

- (2) One set of three specimens for impact test is to be taken from each sample pipe in accordance with Fig 2.1.12. Moreover, for electric resistance welded steel pipes, another set of three specimens is to be taken from the welded zone in accordance with Fig 2.1.13.

Table 2.1.67 Heat Treatment and Mechanical Properties

Grade	Heat treatment	Tensile test <sup>(1)(2)(3)</sup>				Bend test		Impact test	
		Yield strength (N/mm <sup>2</sup> )	Tensile strength (N/mm <sup>2</sup> )	Elongation (%) ( $L = 5.65\sqrt{A}$ )		Inside radius of bend	Angle of bend (°)	Test temp. (°C)	Average absorbed energy (J) <sup>(4)</sup>
				L	T				
<i>RLPA</i>	Normalized, Normalized and tempered or Quenched and tempered	205 min.	380 min.	26 min.	19 min.	6 times the outside diameter of steel pipe	90	-40 <sup>(5)</sup>	27 min.
<i>RLPB</i>								-50 <sup>(5)</sup>	
<i>RLPC</i>								-60 <sup>(5)</sup>	
<i>RLP2</i>		245 min.	450 min.	20 min.	14 min.			-70	34 min.
<i>RLP3</i>								-95	
<i>RLP9</i>	Double normalized and tempered or Quenched and tempered	520 min.	690 min.	15 min.	11 min.	-196	41 min.		

NOTES:

- (1) *L* (or *T*) denotes that the longitudinal axis of the test specimen is arranged parallel (or normal) to the final direction of rolling.
- (2) Where the nominal diameter of steel pipes is 200 mm and over, the tensile test specimen may be taken transversely.
- (3) Where test specimen of non-tubular section is taken from electric resistance welded pipes, the test specimen is to be taken from the portion that does not include the welded line.
- (4) When the absorbed energy of two or more test specimens among a set of test specimens is less in value than the specified average absorbed energy or when the absorbed energy of a single test specimen is less in value than 70% of the specified average absorbed energy, the test is considered to have failed.
- (5) Impact test temperature for steel pipes specified in Pt 7, Ch 5 is to be 5°C below the design temperature or -20°C, whichever is the lower.

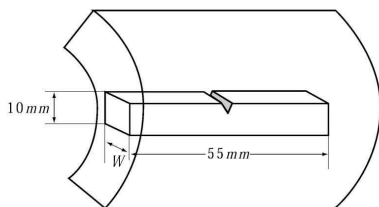


Fig 2.1.12 The position of selection for impact test specimen taken from the seamless steel pipes and other portions than weld zone of electric-resistance welded steel pipes

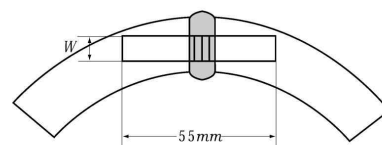


Fig 2.1.13 The position of selection for impact test specimen taken from the weld zone of electric resistance welded steel pipes

## 8. Tolerance for dimensions

The tolerances for outside diameter and wall thickness of steel pipes are to be in accordance with the requirements given in **Table 2.1.68**.

**Table 2.1.68 Tolerance for Outside Diameter and Wall Thickness**

Kind	Tolerance for outside diameter	Tolerance for wall thickness
Hot-finished seamless steel pipe	D < 50 : ± 0.5 mm 50 ≤ D < 250 : ± 1 % (maximum value 2.0 mm) 250 ≤ D : ± 0.8 %	t < 4 : ± 0.5 mm t ≥ 4 : ± 12.5 %
Cold-drawn seamless steel pipe and Electric-resistance welded steel pipe	± 0.8 % (max. value 0.3 mm)	t < 2 : ± 0.2 mm t ≥ 2 : ± 10 %
NOTE: For hot-finished seamless steel pipes, the tolerance for deviation in wall thickness is to be 20 % or less of wall thickness, but it shall not be applied to the pipes less than 5.6 mm in wall thickness.		

## 9. Quality

The steel pipes are to be of uniform quality and free from harmful defects.

## 10. Retest procedures

- (1) Where other mechanical tests than impact tests fail to meet the requirements, additional tests may be carried out according to the requirements given in **109**.
- (2) Regarding the impact tests, additional tests are to be carried out according to the requirements given in **301. 10 (3)**.

## 11. Marking

- (1) Marking for steel pipes is generally to comply with the requirements given in **402. 10.**
- (2) In case the requirement in Note (5) of **Table 2.1.67** has been applied, "impact test temperature T" is to be suffixed to the marking. (e.g. *RLPA-25T*)
- (3) For steel pipes to which the requirements given in **5. (3)**, the specified value of the maximum yield stress or proof stress and "A" are to be suffixed to the markings. (e.g. *RLPB-440A (2023)*)

## 405. Header

### 1. Application

- (1) These requirements are to apply to the headers to be used for boilers.
- (2) The headers having characteristics differing from those specified in **405.** are to comply with the requirements in **101. 2.**

### 2. Kinds

The headers are classified as specified in **Table 2.1.69**.

**Table 2.1.69 Grades of Headers**

Grade	Grade 1	Grade 2	Grade 3	Grade 4	Grade 5	Grade 6
	<i>RBH1</i>	<i>RBH2</i>	<i>RBH3</i>	<i>RBH4</i>	<i>RBH5</i>	<i>RBH6</i>

### 3. Heat treatment

Headers are to be heat treated by annealing or normalizing.

#### 4. Chemical composition

The chemical composition of headers is to comply with the requirements given in **Table 2.1.70**.

**Table 2.1.70 Chemical Composition**

Grade	Chemical composition (%)						
	<i>C</i>	<i>Si</i>	<i>Mn</i>	<i>P</i>	<i>S</i>	<i>Cr</i>	<i>Mo</i>
<i>RBH1</i>	0.25 max.	0.10~0.35	0.30~0.80	0.040 max.	0.040 max.	-	-
<i>RBH2</i>	0.30 max.						
<i>RBH3</i>	0.10~0.20	0.10~0.50	0.30~0.60	0.030 max.	0.030 max.	0.80~1.20	0.45~0.65
<i>RBH4</i>							0.20~0.45
<i>RBH5</i>	0.15 max.						0.45~0.65
<i>RBH6</i>							2.00~2.50

#### 5. Mechanical properties

(1) **Tensile test:** The tensile test of headers is to comply with the requirements given in **Table 2.1.71**.

**Table 2.1.71 Mechanical Properties**

Grade	Yield strength (N/mm <sup>2</sup> )	Tensile strength (N/mm <sup>2</sup> )	Elongation(%) ( $L = 5.65\sqrt{A}$ )	Reduction of area (%)
<i>RBH1</i>	205 min.	410 min.	24 min.	38 min.
<i>RBH2</i>	225 min.	450 min.	23 min.	40 min.
<i>RBH3</i>	205 min.	380 min.	22 min.	
<i>RBH4</i>		410 min.	21 min.	
<i>RBH5</i>				
<i>RBH6</i>				

NOTE:  
When test specimens are taken crosswise to the rolled direction, the values of yield strength and tensile strength are to be as given in this Table and the elongation is to take the value reduced by 5% from the percentage given in this Table. The value of reduction of area may be only remained on records for reference.

(2) **Bend test:** The test specimen is to stand being bent cold through 180° without flaw and cracking on the outside of bent portion to an inside radius of 20 mm. Where the test specimen of 20 mm in thickness can not be taken, the test specimen may be as original in thickness, in which case, however, the width of test specimen is not to be less than 1.5 times the thickness and the inside radius of bend is to be equal to the thickness.

#### 6. Selection of test specimens

- (1) Tensile test specimens are to be taken lengthwise or crosswise to the rolled direction and bend test specimens to be taken crosswise to the rolled direction each from the open ends of headers.
- (2) For the headers of the same size made from the same melt and subjected to the heat treatment simultaneously in the same furnace, tensile and bend test specimens are to be selected in accordance with the requirements given in **Table 2.1.72**.

Table 2.1.72 Number of Test Specimens

Grade	Length of test specimens <i>l</i> (mm)	Number of test specimens
<i>RBH1</i> <i>RBH2</i>	$3000 \leq l$	1 set for each one length
	$2000 \leq l < 3000$	1 set for each three lengths
	$2000 > l$	1 set for each five lengths
<i>RBH3 RBH4</i> <i>RBH5 RBH6</i>	$3000 \leq l$	1 set from each end for each one lengths
	$3000 > l$	1 set for each one length

- (3) Where the both ends of header are closed by reforging, the test samples of proper size may be cut from the open ends before reforging.
- (4) Where test samples cut from circular headers, etc. are necessary to be flattened, the test samples are to be taken from the body before being subjected to the heat treatment and after flattening the test samples are to be heat treated simultaneously with the body in the same furnace, or the test samples are to be cut from the structures after being subjected to the heat treatment and after flattened cold, they are to be heated to the temperature of 600°C to 650°C for the purpose of removing the distortion due to the flattening, and the required test specimens are to be cut from the test samples.

#### 7. Tolerance for thickness

The tolerance for thickness is to be  $\pm 12.5\%$ . The tolerance, however, may not apply to the closed portions of circular or square headers, the side corners of square headers and the corrugated headers.

#### 8. Quality

Headers are to be of uniform quality and free from harmful defects.

#### 9. Marking

Headers which have satisfactorily complied with the required tests are to be marked with the identification mark in accordance with the requirements in **401. 10**.



---

---

## Section 5 Castings

### 501. Steel castings

#### 1. Application

- (1) The requirements in **501.** are to apply to the steel castings intended to be used for ships and offshore units for worldwide services as the components specified in the relevant Parts of hull construction equipments and machinery, except that defined in **502.**, **503.** and **504.**. (2023)
- (2) Additional requirements may be necessary, especially when the castings are intended for service at low or elevated temperatures, e.g. for ships with ice-class or for boilers. (2023)
- (3) Additional requirements will typically be required for castings for offshore units depending on applicable service temperature and environment. (2023)
- (4) Steel castings having characteristics differing from those specified in **501.** are to comply with the requirements in **101. 2.**

#### 2. Kinds

The steel castings are classified as specified in **Table 2.1.73.**

Table 2.1.73 Grades and Mechanical Properties (2019) (2023)

Kind		Grade	Yield strength (N/mm <sup>2</sup> )	Tensile strength (N/mm <sup>2</sup> )	Elongation (%) ( $L = 5.65\sqrt{A}$ )	Reduction of area (%)	Charpy V-notch impact test <sup>(3)</sup>	
							Test temperature(°C)	Minimum average energy(J)
Hull and general steel castings intended for welding	Carbon steel castings	RSC400H	200 min.	400 min.	25 min.	40 min.	0	27
		RSC440H	220 min.	440 min.	22 min.	30 min.		
		RSC480H	240 min.	480 min.	20 min.	27 min.		
		RSC520H	260 min.	520 min.	18 min.	25 min.		
		RSC560H	300 min.	560 min.	15 min.	20 min.		
		RSC600H	320 min.	600 min.	13 min.	20 min.		
	Alloy steel castings	RSC550HA	355 min.	550 min.	18 min.	30 min.		
		RSC600HA	400 min.	600 min.	16 min.	30 min.		
		RSC650HA	450 min.	650 min.	14 min.	30 min.		
		RSC700HA	540 min.	700 min.	12 min.	28 min.		
Machinery steel castings not intended for welding	Carbon steel castings	RSC400M	200 min.	400 min.	25 min.	40 min.	AT <sup>(4)</sup>	27
		RSC440M	220 min.	440 min.	22 min.	30 min.		
		RSC480M	240 min.	480 min.	20 min.	27 min.		
		RSC520M	260 min.	520 min.	18 min.	25 min.		
		RSC560M	300 min.	560 min.	15 min.	20 min.		
		RSC600M	320 min.	600 min.	13 min.	20 min.		
	Alloy steel castings	RSC550MA	340 min.	550 min.	16 min.	35 min.		
		RSC600MA	400 min.	600 min.	16 min.	35 min.		
		RSC650MA	450 min.	650 min.	14 min.	32 min.		
		RSC700MA	540 min.	700 min.	12 min.	28 min.		

NOTES:

- (1) For intermediate values of the tensile strength, the minimum values for yield strength, elongation and reduction of area may be obtained by interpolation and the value at the first decimal place is to be subjected to the method of counting fractions over 1/2 as one and disregarding the rest.
- (2) A tensile strength range of 150 N/mm<sup>2</sup> may additionally be specified.
- (3) Special consideration may be given to alternative requirements for Charpy V-notch impact test, depending on design and application, and subject to agreement by the Society.
- (4) AT refers to Ambient Temperature(i.e. 23°C±5°C), which is specified in ISO 148-1:2016.

### 3. Manufacture

- (1) All flame cutting, scarfing or arc-air gouging to remove the risers and surplus metal is to be undertaken in accordance with recognized good practice and is to be carried out before the final heat treatment. Preheating is to be employed when necessitated by the chemical composition or thickness of the castings. If necessary, the affected areas are to be either machined or ground smooth.
- (2) Where the surface of steel castings is hardened by induction hardening, nitriding, cold rolling or other methods, the proposed methods of manufacture are to be approved by the Society.
- (3) When two or more castings are joined by welding to form a composite component, the proposed welding procedure is to be submitted for approval to the Society. The welding procedure qualification tests are to be required. (2023)
- (4) The welding procedure qualification test and welder qualification test are in accordance with **Pt 2, Ch 2** of the Rules. (2023)
- (5) Temporary welds made for operations such as lifting, handling, staging, etc., are to be in accordance with approved welding procedures and qualified welders, and are to be removed, ground and inspected using suitable NDT methods. (2023)

### 4. Chemical composition [See Guidance]

- (1) All castings are to be made from killed steel and the chemical composition is to comply with the overall limits given in **Table 2.1.74**.
- (2) The chemical composition of each heat is to be determined by the manufacturer on a sample taken preferably during the pouring of the heat. When multiple heats are tapped into a common ladle, the ladle analysis shall apply.

**Table 2.1.74 Chemical Composition (%) (2017) (2023)**

Steel Type	Application	Chemical composition (%)										Total residuals
		C	Si	Mn	S	P	Cu	Cr	Ni	Mo	W	
Carbon steel casting	Casting for non-welded construction	0.40 max.	0.60 max.	0.50-1.60	0.035 max.	0.035 max.	0.30 max. <sup>(2)</sup>	0.30 max. <sup>(2)</sup>	0.40 max. <sup>(2)</sup>	0.15 max. <sup>(2)</sup>	-	0.80 max.
	Casting for welded construction	0.23 max. <sup>(1)</sup>	0.60 max.	0.50-1.60	0.035 max.	0.035 max.	0.30 max. <sup>(2)</sup>	0.30 max. <sup>(2)</sup>	0.40 max. <sup>(2)</sup>	0.15 max. <sup>(2)</sup>	-	0.80 max.
Alloy steel casting	Casting for non-welded construction	0.45 max.	0.60 max.	0.50 - 1.60	0.030 max.	0.035 max.	0.30 min. <sup>(2)(3)</sup>	0.40 min. <sup>(2)(3)</sup>	0.40 min. <sup>(2)(3)</sup>	0.15 min. <sup>(2)(3)</sup>	-	-
	Casting for welded construction	0.25 max.	0.60 max.	0.50 - 0.80	0.030 max.	0.030 max.	0.50 max. <sup>(2)</sup>	1.50 max. <sup>(3)</sup>	0.50 max. <sup>(2)</sup>	1.20 max. <sup>(3)</sup>	0.10 max. <sup>(2)</sup>	1.00 max.

**NOTES :**

- (1) The carbon content may be, subject to approval by the Society, increased above this level provided that the carbon equivalent ( $C_{eq}$ ) is not more than 0.41%. **[See Guidance]**
- (2) Elements are considered as residual elements.
- (3) One or more of the elements is to comply with the minimum content.

- (3) Suitable grain refining elements such as aluminium may be used at the discretion of the manufacturer or as agreed with the Society.

## 5. Heat treatment

- (1) Steel castings are to be supplied in one of the conditions given in **Table 2.1.75**. No fully annealed casting is to be removed from the furnace until the temperature of the entire furnace charge has fallen to or below a temperature of 455°C. The tempering temperature is to be not less than 550°C. (2022) (2023)

**Table 2.1.75 Heat treatment (2023)**

Steel Type	Heat treatment
Carbon steel casting	Fully Annealed Normalized Normalized and tempered Quenched and tempered
Alloy steel casting	Normalized Normalized and tempered Quenched and tempered

- (2) The delivery condition shall meet the design and application requirements. It is the manufacturer's responsibility to select the appropriate heat treatment method to obtain the required mechanical properties. (2023)
- (3) If a casting is locally reheated or any straightening operation is performed after the final heat treatment, a subsequent stress relieving heat treatment may be required in order to avoid the possibility of harmful residual stresses. The manufacturer shall have strict control of this temperature in order to avoid any detrimental effects to the final heat treatment and resultant microstructure and mechanical properties of the casting. (2022) (2023)
- (4) Castings for components such as crankshafts and engine bedplates, where dimensional stability and freedom from internal stresses are important, are to be given a stress relief heat treatment. This is to be carried out at a temperature of not less than 550°C followed by furnace cooling to 300°C or lower.
- (5) Heat treatment is to be carried out in properly constructed furnaces which are efficiently maintained and have adequate means for control and recording of temperature. The furnace dimensions are to be such as to allow the whole casting to be uniformly heated to the necessary temperature. In the case of very large castings alternative methods for heat treatment will be specially considered by the Society.  
Sufficient thermocouples are to be connected to the furnace charge to measure and record that its temperature is adequately uniform unless the temperature uniformity of the furnace is verified at regular intervals.
- (6) The foundry is to maintain records of heat treatment identifying the furnace used, furnace charge, date, temperature and time at temperature. The records are to be presented to the Surveyor on request.

## 6. Mechanical properties

The mechanical properties of the steel castings are to comply with the requirements given in **Table 2.1.73**.

## 7. Selection of test specimens

- (1) At least one test block is to be provided for each casting. Unless otherwise agreed these test blocks are to be either integrally cast or gated to the castings. One tensile test specimen and one set of impact tests are to be taken from each test block. These test blocks are to have a thickness of not less than 30 mm. Test material, sufficient for the required tests and for possible retest purposes is to be provided for each casting or batch of castings. (2023) (2024)
- (2) The test blocks are to be heat treated together with the castings which they represent and are not to be detached from the casting until the specified heat treatment has been completed and they have been properly identified. (2023)
- (3) For castings where the method of manufacture has been specially approved by the Society in accordance with 3 (2), the number and position of test samples is to be agreed with the Society

- having regard to the method of manufacture employed.  
(4) Number of test blocks is to comply with the requirements of **Table 2.1.76**. (2023)

**Table 2.1.76 Number of test blocks (2023)**

Condition of casting	Number of test blocks
Where the weight of one steel casting is between 1 ton and 10 tons inclusive	1 for each casting <sup>(1)</sup>
Where the casting is of complex design or where the finished weight exceeds 10 tons	2 for each casting <sup>(1)(3)</sup>
Where large castings are made from two or more casts which are not mixed in a ladle prior to pouring.	Two or more corresponding to the number of casts involved <sup>(1)</sup>
Where a number of small castings with a weight of 1 ton or less which are to be of similar type and dimensions, made from one cast and heat-treated in the same furnace charge.	1 for each batch of castings <sup>(2)</sup>
<p>NOTES:</p> <p>(1) These test blocks are to be integrally cast at locations as widely separated as possible.</p> <p>(2) Test blocks are to be separately casted and are to have suitable dimensions.</p> <p>(3) Test blocks are from the heaviest section.</p>	

## 8. Surface and dimension inspections **【See Guidance】**

- (1) When heat treatment and machining are finished and, if necessary, at a proper time during machining, surface inspection is to be carried out. Where applicable, this is to include the examination of internal surfaces. Testing methods and acceptance criteria are to be in accordance with the Guidance relating to the Rules specified by the Society.
- (2) All castings are to be cleaned and adequately prepared for examination; suitable methods include pickling, caustic cleaning, wire brushing, local grinding, shot or sand blasting. The surfaces are not to be hammered, peened or treated in any way which may obscure defects.
- (3) The dimension inspection of the steel castings is to be conducted under the responsibility of the manufacturer, unless otherwise specified.

## 9. Quality

- (1) All castings are to be free from surface or internal defects, which would be prejudicial to their proper application in service.
- (2) In the event of any casting proving to be defective during subsequent machining or testing it is to be rejected notwithstanding any previous certification.

## 10. Non-destructive inspection

- (1) The steel castings intended for stern frame, rudder post and other important structural members or the steel castings specified in **Pt 5, Ch 2, 201. 1** are to be subjected to ultrasonic tests at an appropriate stage of the manufacturing process and the test reports are to be showed or submitted to the Surveyor. Testing methods and acceptance criteria are to be in accordance with the Guidance relating to the Rules specified by the Society. **【See Guidance】**
- (2) The important parts of the following steel castings are to be subjected to magnetic particle tests at an appropriate stage of the manufacturing process. But, machining surfaces may be subjected to liquid penetrant tests. Testing methods and acceptance criteria are to be in accordance with the Guidance relating to the Rules specified by the Society. **【See Guidance】**
  - (a) Steel castings intended for stern frame, rudder post and other important structural members
  - (b) Steel castings specified in **Pt 5, Ch 2, 201. 1**
  - (c) Propellers
  - (d) Turbine castings
- (3) When required by the relevant construction Rules, castings are to be pressure tested before final acceptance. These tests are to be carried out in the presence of the Surveyor and are to be

- to their satisfaction.
- (4) In place of the test methods specified in (1) and (2), the Society may accept the application of other non-destructive inspections considered adequate by the Society.
  - (5) The Society may require non-destructive inspections by radiographic test, ultrasonic test, magnetic particle test or penetrant test not only for the steel casting specified in (1) and (2) but also for the steel casting deemed necessary by the Society.
  - (6) The welding parts of steel castings used to welded construction are to be subjected to non-destructive inspections considered adequate by the Society.

## 11. Repair of defects

### (1) General

- (A) Where castings are to be repaired, the manufacturer shall exercise robust controls of all repair operations regarding the repair of castings, with respect to dimensions, heat treatment, inspection and quality control. (2023)
- (B) The approval of the Society is to be obtained where steel castings from which defects were removed are to be used with or without weld repair.
- (C) Defects and unacceptable indications must be repaired as indicated below. (2023)
  - (a) Defective parts of material may be removed by grinding, or by chipping and grinding, or by arc air-gouging and grinding.
  - (b) Thermal methods of metal removal shall only be allowed before the final heat treatment.
  - (c) All grooves shall have a bottom radius of approximately three times the groove depth and should be smoothly blended to the surface area with a finish equal to that of the adjacent surface.
- (D) For crank throws and steel alloy castings, procedure of removal of defect and weld repair is to be in accordance with the Guidance relating to the Rules specified by the Society. (2023)

#### **[See Guidance]**

- (E) Where the defective area is to be repaired by welding, the excavations are to be suitably shaped to allow good access for welding. The resulting grooves are to be subsequently ground smooth and complete elimination of the defective material is to be verified by magnetic particle test or liquid penetrant test.
- (F) Shallow grooves or depressions resulting from the removal of defects may be accepted provided that they will cause no appreciable reduction in the strength of the casting or affect the intended use, and the depth of defect removal is not over 15 mm or 10 % of wall thickness, whichever is less. The resulting grooves or depressions are to be subsequently ground smooth and complete elimination of the defective material is to be verified by magnetic particle test or liquid penetrant test. (2023)

### (2) Weld repairs

In addition to (1), when a casting can be repaired by welding, the following requirements apply: (2023)

- (A) For C and C-Mn steel castings weld repairs shall be suitably classified as major or minor. For alloy steel castings, repair requires approval from the Society. (2023)
  - (a) Major repairs are those where:
    - (i) The depth is greater than 25 % of the wall thickness or 25 mm whichever is less, or
    - (ii) The total weld area on a casting exceeds 0.125 m<sup>2</sup> of the casting surface noting that where a distance between two welds is less than their average width, they are to be considered as one weld.
  - (b) Minor weld repairs:

Weld repairs not classified as major are considered as minor and need to be carried out in accordance with a qualified welding procedure.
- (B) The following is required for major repairs: (2023)
  - (a) Shall be carried out before the final delivery heat treatment condition
  - (b) Shall comply with the requirements in (D) below
  - (c) Before welding is started, full details of the extent and location of the repair, the proposed welding procedure, heat treatment and subsequent inspection procedures are to be submitted for approval.
- (C) The following is required for minor repairs: (2023)
  - (a) Shall be carried out before the final delivery heat treatment condition
  - (b) Shall comply with the requirements in (D) below
  - (c) With the exception of alloy steels, do not require prior approval by the Classification Society, except as given in (d)

- (d) The Society may request minor repairs in critical areas to be treated as major repairs.
- (D) The following requirements apply for all weld repairs (major and minor):
- (a) All castings in alloy steels and all castings for crankshafts are to be suitably pre-heated prior to welding. Castings in carbon steel may also require to be pre-heated depending on their chemical composition, the dimensions and position of the weld repairs.
  - (b) Welding procedures are to be qualified and shall match the delivery condition of the casting. Qualification of welding procedures shall follow **Pt 2, Ch 2, Sec 4** of the Rules or a recognised standard. (2023)
  - (c) Welding is to be done under cover in positions free from draughts and adverse weather conditions by qualified welders with adequate supervision. As far as possible, all welding is to be carried out in the downhand (flat) position.
  - (d) The welding consumables used are to be of an appropriate composition, giving a weld deposit with mechanical properties similar and in no way inferior to those of the parent castings.  
Welding procedure tests are to be carried out by the manufacturer to demonstrate that satisfactory mechanical properties can be obtained after heat treatment as detailed in 5.
  - (e) After welding has been completed the castings are to be given either a suitable heat treatment in accordance with the requirements of previous 5 (1) or a stress relieving heat treatment at a temperature of not less than 550°C for C and C-Mn steel castings. For alloy steel castings, the heat treatment has to be agreed with the Society. The type of heat treatment employed will be dependent on the chemical composition of the casting and the dimensions, positions and nature of the repairs, and should not affect the properties of the casting. (2023)
  - (f) Subject to the prior agreement of the Society, special consideration may be given to the omission of postweld heat treatment or to the acceptance of local stress-relieving heat treatment where the repaired area is small and machining of the casting has reached an advanced stage.
  - (g) On completion of heat treatment the weld repairs and adjacent material are to be ground smooth and examined by magnetic particle or liquid penetrant testing. Supplementary examination by ultrasonics or radiography ultrasonic or radiographic testing may also be required depending on the dimensions and nature of the original defect. Satisfactory results are to be obtained from all forms of non-destructive testing used. (2023)
  - (h) The manufacturer is to maintain full records detailing the extent and location of repairs made to each casting and details of weld procedures and heat treatments applied for repairs. These records are to be available to the Surveyor and copies provided on request. (2023)
- (3) Recommendation for welding  
For steels with  $C \geq 0.23$  or  $C_{eq} \geq 0.45$ , the WPQT on which the WPS is based, should be qualified on a base material having a  $C_{eq}$  as follows: the  $C_{eq}$  of the base material should not fall below more than 0.02 of the material to be welded. (Example: WPQT for a material with actual  $C_{eq} = 0.50$  may be qualified on a material with  $C_{eq} \geq 0.48$ .) (2023)

## 12. Retest procedure

- (1) Where the tensile test fails to meet the requirements, additional test may be carried out in accordance with the requirements of **109**.
- (2) The additional tests are to be taken, preferably from the same, but alternatively from another, test sample representative of the casting or batch of castings.
- (3) At the option of the manufacturer, when a casting or batch of castings has failed to meet the test requirements, it may be reheat treated and re-submitted for acceptance tests.

## 13. Marking

- (1) The grade of material and the manufacturer's name or trade mark are to be cast or stamped on all steel castings. In addition, the cast number is to be stamped on all steel castings not less than 250 kg in mass. The Society's brand indicating satisfactory compliance with the requirements is to be stamped in the vicinity of the foregoing marks.
- (2) For steel castings to which the requirements given in note 1 of the **Table 2.1.70**, the material symbols are specified as *RSC* – (or *RSC – A*) and the required tensile strength is to be filled in symbol " – ". (e.g. For carbon steel castings which the required tensile strength is 420  $N/mm^2$ , *RSC 420*)

## 14. Test certificates (2017)

The manufacturer is to provide the required type of inspection certificate giving the following particulars for each casting or batch of castings which has been accepted:

- (1) Purchaser's name and order number
- (2) Description of castings and steel quality
- (3) Identification number
- (4) Steel making process, cast number and chemical analysis of ladle samples
- (5) Results of mechanical tests
- (6) Results of non-destructive tests, where applicable
- (7) Details of heat treatment, including temperatures and holding times
- (8) Where applicable, test pressure

**15. Additional requirements for crank throw**

- (1) In case where semi-built-up crank throw for diesel engines is made of steel casting, the manufacturing procedure is to be approved by the Society.
- (2) Where special manufacturing methods are adopted to reduce the size of crank throw according to the requirements in **Pt 5, Ch 2, 208**, the preliminary test instructed by the Society are to be carried out.



## 502. Steel castings for chains

### 1. Application

- (1) These requirements are to apply to the steel castings used for anchor chain cables and accessories specified in **Pt 4, Ch 8** (hereinafter referred to as "steel castings").
- (2) Steel castings for manufacture of offshore mooring chain accessories are to be in accordance with the Guidance relating to the Rules specified by the Society. **【See Guidance】**
- (3) Steel castings having characteristics differing from those specified in **502.** are to comply with the requirements in **101. 2.**

### 2. Kinds

The steel castings are classified as specified in **Table 2.1.77.**

**Table 2.1.77 Grade of Steel Casting**

Grade	Application
<i>RSCC 50</i>	Grade 2 chain
<i>RSCC 70</i>	Grade 3 chain

### 3. Heat treatment

- (1) Steel castings are to be normalized, normalized and tempered, quenched and tempered or heat treated by the process approved by the Society.
- (2) Steel castings which are locally heated or subjected to any cold work after heat treatment, are to be stress-relieved by the approved methods.
- (3) Flame cutting or scarfing to remove risers and surplus metals is to be completed before final heat treatment of the steel castings.

### 4. Chemical composition

Chemical composition of steel castings is to be subjected to the special approval by the Society.

### 5. Mechanical properties

The mechanical properties of steel castings are to comply with the requirements given in **Table 2.1.78.**

**Table 2.1.78 Mechanical Properties**

Grade	Tensile test				Impact test <sup>(1)</sup>	
	Yield strength (N/mm <sup>2</sup> ) <sup>(2)</sup>	Tensile strength (N/mm <sup>2</sup> ) <sup>(2)</sup>	Elongation (%) ( <i>L</i> =5 <i>d</i> )	Reduction of area (%)	Testing temp. (°C)	Average absorbed energy (J)
<i>RSCC 50</i>	295 min.	490~690	22 min.	-	-	-
<i>RSCC 70</i>	410 min.	690 min.	17 min.	40 min.	0	60 min.

NOTE:

(1) When the absorbed energy of two or more test specimens among a set of test specimens is less in value than the specified average absorbed energy or when the absorbed energy of a single test specimen is less in value than 70 % of the specified average absorbed energy, the test is considered to have failed.

### 6. Selection of test specimens

- (1) One test sample is to be taken from castings of similar dimensions originating from the same heat treatment charge and the same cast of steel. In this case, the test sample may be the test assembly cast with the body of casting and similar area. The tensile and impact test specimens are to be taken from the test sample in the longitudinal direction at a depth of 1/6

diameter from the surface specified in Fig 2.1.5.

- (2) For *RSCC* 50, one tensile test specimen, and for other grades of chain castings, one tensile test specimen and one set (3 pieces) of impact test specimens are to be taken from the test sample.

#### 7. Surface inspection

Steel castings are to be subjected to the surface inspection after completion of the final heat treatment.

#### 8. Quality

Steel castings are to be of uniform quality and free from harmful defects.

#### 9. Non-destructive inspection

A suitable non-destructive inspection, such as an ultrasonic test, may be required where deemed necessary by the Society.

#### 10. Repair of defects

The repair of defects for steel castings is generally to be carried out in accordance with the requirements in 501. 11.

#### 11. Retest procedure

Where the tensile test or impact test on the selected first test specimens fails to meet the requirements, additional tests may be conducted according to the requirements given in 306. 7.

#### 12. Marking

Steel castings which have satisfactorily complied with the required tests are to be marked with the identification mark in accordance with the requirements in 501. 13 (1).

### 503. Stainless steel castings

#### 1. Application

- (1) The requirements are to apply to the stainless steel castings for valves and pipe fittings in piping systems used at low temperature ( $-165^{\circ}\text{C}$  and over in design temperature) service or corrosion-resisting service (hereinafter referred to as "steel castings").
- (2) Steel castings having characteristics differing from those specified in 503. are to comply with the requirements in 101. 2.

#### 2. Kinds

The steel castings are classified as specified in Table 2.1.79.

#### 3. Heat treatment

Steel castings are generally to receive a solid solution treatment.

#### 4. Chemical composition

The chemical composition of steel castings is to comply with the requirements given in Table 2.1.79.

**Table 2.1.79 Grades and Chemical Composition**

Grade	Chemical composition (%)										
	C	Si	Mn	P	S	Ni	Cr	Mo	Other		
<i>RSSC 13</i>	0.08 max.	2.00 max.	2.00 max.	0.040 max.	0.030 max.	8.00~11.00	18.00~21.00	—	—		
<i>RSSC 14</i>		1.50 max.				10.00~14.00	17.00~22.00	2.00~3.00	—		
<i>RSSC 16</i>	12.00~16.00					—					
<i>RSSC 17</i>	0.08 max.	2.00 max.				0.040 max.	0.030 max.	12.00~15.00	22.00~26.0	—	—
<i>RSSC 18</i>								19.00~22.00	23.00~27.0	—	—
<i>RSSC 19</i>	0.030 max.							8.00~12.00	17.00~21.0	—	—
<i>RSSC 21</i>	0.08 max.							9.00~12.00	18.00~21.0	1.35≥Nb+Ta≥10×C	

**5. Mechanical properties**

- (1) The mechanical properties of steel castings are to comply with the requirements give in **Table 2.1.80**.
- (2) Where deemed necessary by the Society, impact test or corrosion-resistance test may be required in addition to the specified tests.

**6. Selection of test specimens**

- (1) Where a stainless steel casting is 500 kg and over in weight, one tensile test specimen and one hardness test specimen are to be taken from each casting.
- (2) Where a number of stainless steel castings of similar form and size, each of which weight less than 500 kg, are cast from the same charge, two tensile test specimens and two hardness test specimens are to be taken from each group of castings simultaneously heat treated in the same furnace.
- (3) Hardness test specimen may be a portion of tensile test specimen.

**7. Marking**

Steel castings which have satisfactorily complied with the required tests are to be marked with the identification mark in accordance with the requirements in **110**.

**Table 2.1.80 Mechanical Properties**

Grade	Tensile test			Hardness test
	Yield strength (N/mm <sup>2</sup> )	Tensile strength (N/mm <sup>2</sup> )	Elongation(%) ( $L = 5.65\sqrt{A}$ )	Brinell $H_{BW}$
<i>RSSC 13</i>	185 min.	440 min.	26 min.	183 max.
<i>RSSC 14</i>				
<i>RSSC 16</i>	175 min.	390 min.	31 min.	
<i>RSSC 17</i>	205 min.	440 min.	26 min.	
<i>RSSC 18</i>	185 min.			
<i>RSSC 19</i>		390 min.	31 min.	
<i>RSSC 21</i>	205 min.	440 min.	26 min.	

## 504. Steel castings for low temperature service

### 1. Application

- (1) The requirements are to apply to the steel castings for valves and pipe fittings in piping systems intended to be used at the design temperature lower than 0°C in liquefied gas carriers (hereinafter referred to as "steel castings").
- (2) Steel castings other than specified in **504**, or those used in other parts than specified in (1) are to comply with the requirements given in **101. 2**.

### 2. Kinds

The steel castings are classified as given in **Table 2.1.81**.

**Table 2.1.81 Grades and Chemical Composition**

Grade	Deoxidation	Chemical composition (%)						
		<i>C</i>	<i>Si</i>	<i>Mn</i>	<i>P</i>	<i>S</i>	<i>Ni</i>	<i>Mo</i>
<i>RLCA</i>	Fully killed fine grain	0.30 max.	0.60 max.	1.00 max.	0.035 max.	0.035 max.	-	-
<i>RLCB</i>		0.25 max.		0.50~0.80				0.030 max.
<i>RLC2</i>		0.25 max.			-	2.00~3.00	-	
<i>RLC3</i>		0.15 max.		3.00~4.00				-

### 3. Heat treatment

Steel castings are to be normalized or normalized and tempered.

### 4. Deoxidation practice and chemical composition

The deoxidation practice and chemical composition of steel castings are to comply with the requirements given in **Table 2.1.81**.

### 5. Mechanical properties

- (1) The mechanical properties of steel castings are to comply with the requirements given in **Table 2.1.82**.
- (2) Where deemed necessary by the Society, other tests may be required in addition to the tests specified in (1).

**Table 2.1.82 Mechanical Properties**

Grade	Tensile test				Impact test <sup>(2)</sup>			
	Yield strength (N/mm <sup>2</sup> )	Tensile strength (N/mm <sup>2</sup> )	Elongation (%) ( <i>L</i> = 5 <i>d</i> )	Reduction of area (%)	Test temp. (°C)	Average absorbed energy (J)		
<i>RLCA</i>	245 min.	450 min.	21 min.	35 min.	-40 <sup>(1)</sup>	27 min.		
<i>RLCB</i>					-50 <sup>(1)</sup>			
<i>RLC2</i>	275 min.				-	-	-70	34 min.
<i>RLC3</i>							-95	

**NOTES:**

- (1) Impact test temperature for castings specified in **Pt 7, Ch 5** is to be 5°C below the design temperature or -20°C, whichever is the lower.
- (2) When the absorbed energy of two or more test specimens among a set of test specimens is less in value than the specified average absorbed energy or when the absorbed energy of a single test specimen is less in value than 70 % of the specified average absorbed energy, the test is considered to have failed.

### 6. Selection of test specimens

- (1) Where a steel casting is 500 kg and over in weight, one tensile test specimen and one set of three impact test specimens are to be taken from each casting.
- (2) Where a number of steel castings of similar form and size, each of which less than 500 kg in weight, are cast from the same charge, two tensile test specimens and two sets of six impact test specimens are to be taken from each group of castings simultaneously heat treated in the same furnace.

#### 7. Retest procedures

- (1) Where the tensile tests fail to meet the requirements, additional tests may be carried out according to the requirements given in **109**.
- (2) Regarding the impact tests, additional tests are to be carried out according to the requirements given in **304. 9 (2)**.

#### 8. Marking

Steel castings which have satisfactorily complied with the required tests are to be marked with the identification mark in accordance with the requirements in **501. 13 (1)** and in case the requirement in Note (1) of **Table 2.1.82** has been applied, "impact test temperature T" is to be suffixed to the marking. (e.g. *RLCA - 25T*)

### 505. Stainless steel casting for propeller

#### 1. Application

- (1) These requirements are applicable to the manufacture, inspection and repair procedures of stainless steel casting (hereinafter referred to as "**steel propeller casting**") for propellers, blades and bosses. These requirements may also be used for the repair of propellers damaged in service, subject to prior agreement with the Society. (2021) **[See Guidance]**
- (2) Steel propeller castings having characteristics differing from those specified in **505**. are to comply with the requirements in **101. 2**.

#### 2. Kinds

Steel propeller castings are classified as specified in **Table 2.1.83**.

#### 3. Chemical composition (2021)

- (1) Chemical composition is classified as specified in **Table 2.1.83**. Cast steel whose chemical composition deviate from the typical values of **Table 2.1.83** must be specially approved by the Society.
- (2) The manufacturer is to maintain records of the chemical analyses of the production casts, which are to be made available to the Surveyor so that he can satisfy himself that the chemical composition of each casting is within the specified limits.

**Table 2.1.83 Kinds and Chemical Composition**

Alloy type		Chemical composition (%)				
		<i>C</i>	<i>Mn</i>	<i>Cr</i>	<i>Mo</i> <sup>(1)</sup>	<i>Ni</i>
12Cr1Ni	Martensitic	0.15 Max.	2.0 Max.	11.5 – 17.0	0.5 Max.	2.0 Max.
13Cr4Ni		0.06 Max.	2.0 Max.	11.5 – 17.0	1.0 Max.	3.5 – 5.0
16Cr5Ni		0.06 Max.	2.0 Max.	15.0 – 17.5	1.5 Max.	3.5 – 6.0
19Cr11Ni	Austenitic	0.12 Max.	1.6 Max.	16.0 – 21.0	4.0 Max.	8.0 – 13.0
NOTE :						
(1) Minimum values may be in accordance with recognised national or international standards, subject to prior agreement with the Society.						

#### 4. Heat treatment

Martensitic castings are to be austenitized (quenching) and tempered. Austenitic castings should be

solution treated.

### 5. Mechanical properties

The mechanical properties are to meet the requirements in **Table 2.1.84**. These values refer to the test specimens machined from integrally cast test bars attached to the hub or on the blade. The thickness of test coupon is to be in accordance with a recognized standard. (2021)

**Table 2.1.84 Mechanical Properties**

Types	Tensile test				Impact test
	Yield strength <sup>(1)</sup> (N/mm <sup>2</sup> )	Tensile strength (N/mm <sup>2</sup> )	Elongation (%)	Reduction area (%)	Average absorbed energy (J) <sup>(3)</sup>
12Cr1Ni	440 Min.	590 Min.	15 Min.	30 Min.	20 Min.
13Cr4Ni	550 Min.	750 Min.	15 Min.	35 Min.	30 Min.
16Cr5Ni	540 Min.	760 Min.	15 Min.	35 Min.	30 Min.
19Cr11Ni	180 Min. <sup>(2)</sup>	440 Min.	30 Min.	40 Min.	–

NOTES  
(1) 0.2 % yield strength  
(2) 1.0 % yield strength is min. 205 N/mm<sup>2</sup>.  
(3) Not required for general service and the lowest Ice class notation(Grade ID). For other Ice class notations, tests are to be made –10°C.

### 6. Selection of test samples and specimens

- (1) Where possible, the test samples attached on blades are to be located in an area between 0.5 to 0.6 *R*, where *R* is the radius of the propeller.
- (2) The test samples are not to be detached from the casting until the final heat treatment has been carried out. Removal is to be by non-thermal procedures.
- (3) Separately cast test samples may be used subject to prior approval of the Society. The test samples are to be cast from the same heat as the castings represented and heat treated with the castings represented.
- (4) At least one set of mechanical tests is to be made on material representing each casting. However, where a number of small propellers of about the same size, and less than 1 m in diameter, are made from one cast and heat treated in the same furnace charge, a batch testing procedure may be adopted using separately cast test samples of suitable dimensions. At least one set of mechanical tests is to be provided for each multiple of five castings in the batch.

### 7. Quality of castings (2021)

- (1) All castings are to have a workmanlike finish and are to be free from imperfections defects which would be prejudicial to their proper application in service.
- (2) Minor casting defects which may still be visible after machining such as small sand and slag inclusions, small cold shuts and scabs shall be trimmed off by the manufacturer in accordance with **10.**
- (3) Casting defects which may impair the serviceability of the castings, e.g. major non-metallic inclusions, shrinkage cavities, blow holes and cracks, are not permitted. They may be removed by one of the methods described in **10.** and repaired within the limits and restrictions for the severity zones. Full description and documentation must be available for the surveyor.

### 8. Surface and dimension inspection

- (1) All finished castings are to be 100% visually inspected by the manufacturer. A general visual examination is to be carried out by the Surveyor. (2021)
- (2) Steel propeller castings are to be free from cracks, hot tears or other imperfections which, due to their nature, degree or extent, will interfere with the use of the castings.
- (3) The verification of dimensions, the dimensional and geometrical tolerances is the responsibility of the manufacturer. The report on the relevant examinations is to be submitted to the Surveyor,

who may require checks to be made in his presence. (2021)

### 9. Non-destructive inspection

- (1) The important parts of steel propeller casting are to be subjected to the liquid penetrant test in accordance with the Guidance relating to Rules specified by the Society. **[See Guidance]**
- (2) Qualification of personnel involved in NDT is in accordance with **Appendix Pt B 1.4, 1.5 and 1.9 of Guidance for Approval of Service Suppliers.** (2021)
- (3) The division of severity zones of steel propeller casting is to be in accordance with the Guidance relating to Rules specified by the Society. **[See Guidance]**
- (4) Where serious doubt exists that the castings are not free from internal defects, further non-destructive inspections are to be carried out upon request of the Surveyor, e.g. radiographic and/or ultrasonic tests. The acceptance criteria are then to be agreed between the manufacturer and the Society.
- (5) The foundry is to maintain records of inspections traceable to each propeller casting. These records are to be reviewed by the Surveyor. The foundry is also to provide the Surveyor with a statement confirming that non-destructive tests have been carried out with satisfactory results.

### 10. Repair of defects

- (1) In general the repairs are to be carried out by mechanical means, e.g. by grinding, chipping or milling. Where the steel propeller castings from which defects were removed are used in that condition, the steel propeller castings are to be approved by the Surveyor. (2021)
- (2) The resulting grooves are to be blended into the surrounding surface so as to avoid any sharp contours. Complete elimination of the defective material is to be verified by liquid penetrant testing, or magnetic particle testing if applicable. (2021)
- (3) Weld repairs are to be undertaken only when they are considered to be necessary and have prior approval of the Surveyor. Welds having an area less than 5 cm<sup>2</sup> are to be avoided.
- (4) The repair welding procedures are to have prior approval of the Surveyor in accordance with the Guidance relating to the Rules specified by the Society. **[See Guidance]**
- (5) The foundry is to maintain records of inspections, welding, and any subsequent heat treatment, traceable to each casting. Before welding is started, full details of the extent and location of the repair, the proposed welding procedure, heat treatment and subsequent inspection procedures are to be submitted to the Society for approval. (2021)

### 11. Retest procedure

Where the results of tensile tests fail to meet the requirements, additional test may be carried out in accordance with the requirements of **109**.

### 12. Marking (2021)

- (1) The manufacturer is to adopt a system for the identification of all castings, which enable the material to be traced to its original cast. The Surveyor is to be given full facilities for so tracing the castings when required.
- (2) Steel propeller castings which have satisfactorily complied with the required tests are to be marked with the identification mark in accordance with the requirements in **110**. and as follows.
  - (a) Heat number or other marking which will enable the full history of the casting to be traced
  - (b) Grade of cast material or corresponding abbreviated designation
  - (c) Ice class symbol, where applicable
  - (d) Skew angle for high skew propellers
  - (e) Date of final inspection

### 13. Test certificates (2017)

The manufacturer is to provide the Surveyor with an inspection certificate giving the following particulars for each casting which has been accepted:

- (1) Purchaser's name and order number
- (2) Vessel identification, where known
- (3) Description of the casting with drawing number
- (4) Diameter, number of blades, pitch, direction of turning
- (5) Skew angle for high skew propellers
- (6) Final weight
- (7) Alloy type, heat number and chemical composition
- (8) Casting identification number
- (9) Details of time and temperature of heat treatment

- (10) Results of the mechanical tests
- (11) Results of non-destructive tests and details of test procedure where applicable (2021)

## 506. Grey iron castings

### 1. Application

- (1) These requirements are to apply to the grey iron castings (hereinafter referred to as "iron castings") intended to be used for propeller or important parts of machinery.
- (2) Where deemed necessary by the Society, KS or equivalent thereto may be applied. **[See Guidance]**
- (3) Where small castings are produced in large quantities, the manufacturer may adopt alternative procedures for testing and inspection subject to the approval of the Society.

### 2. Manufacture

- (1) The manufacturer has the necessary manufacturing and testing facilities and the manufacturing processes are to be approved by the Society.
- (2) Suitable mechanical methods are to be employed for the removal of surplus material from castings. Thermal cutting processes are not acceptable, except as a preliminary operation to mechanical methods.
- (3) Where castings of the same type are regularly produced in quantity, the manufacturer, subject to the approval of the Society, is to make any tests necessary to prove the quality of the prototype castings and is also to make periodical examinations to verify the continued efficiency of the manufacturing technique. The Surveyor is to be given the opportunity to witness these tests.

### 3. Grade and mechanical properties

Grey iron castings are to comply with the **ISO 185**. However, the minimum tensile strength is to be not less than 200 N/mm<sup>2</sup>

### 4. Chemical composition

- (1) The chemical composition of the iron used is left to the discretion of the manufacturer, who is to ensure that it is suitable to obtain the mechanical properties specified for the castings.
- (2) When required by the Societies the chemical composition of ladle samples is to be reported.

### 5. Heat treatment

- (1) Except as required by (2) castings may be supplied in either the as cast or heat treated condition.
- (2) For some applications, such as high temperature service or where dimensional stability is important, castings may require to be given a suitable tempering or stress relieving heat treatment

### 6. Selection of test samples and specimens

- (1) Test material sufficient for the required tests and for possible re-tests is to be provided for each casting or batch of castings.
- (2) Separately cast test samples are to be used in principle and are to be cast from the same ladle as the castings in moulds of the same type of material as the moulds for the castings
- (3) Test samples are to be in the form of bars 30 mm in diameter and of a suitable length.
- (4) When two or more test samples are cast simultaneously in a single mould, the bars are to be at least 50 mm apart as given in **Fig 2.1.14**.



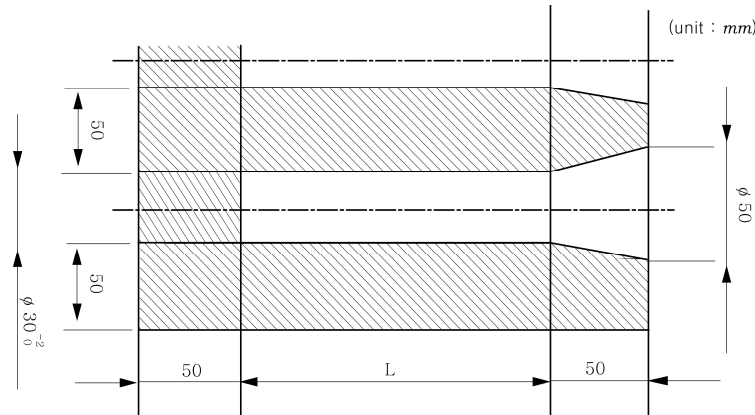


Fig 2.1.14 Sample distance

- (5) Cast test samples are not to be stripped from the moulds until the metal temperature is below 500°C.
- (6) Integrally cast samples may be used when a casting is more than 20 mm thick and its mass exceeds 200 Kg, subject to agreement between the manufacturer and the purchaser. The type and location of the sample are to be selected to provide approximately the same cooling conditions as for the casting it represents and also subject to agreement.
- (7) The numbers of test specimen are as below :
  - (a) With the exception of (d) below, at least one test sample is to be cast with each batch.
  - (b) With the exception of (c) below, a batch consists of the castings poured from a single ladle of metal, provided that they are all of similar type and dimensions. A batch should not normally exceed two tonnes of fettled castings and a single casting will constitute a batch if its mass is 2 tonnes or more.
  - (c) For continuous melting of the same grade of cast iron in large tonnages the mass of a batch may be increased to the output of 2 hours of pouring.
  - (d) If one grade of cast iron is melted in large quantities and if production is carefully monitored by systematic checking of the melting process, such as chill testing, chemical analysis or thermal analysis, test samples may be taken at longer intervals. **【See Guidance】**
- (8) All test samples are to be suitably marked to identify them with the castings which they represent.
- (9) Where castings are supplied in the heat treated condition, the test samples are to be heat treated together with the castings which they represent. For cast-on-test samples the sample shall not be cut off from the casting until after the heat treatment.
- (10) One tensile test specimen is to be prepared from each test sample. Where test samples of other dimensions are specially required the tensile test specimens are to be machined to agreed dimensions.
- (11) All tensile tests are to be carried out using test procedures in accordance with the requirements specified in **203. 1**.

## 7. Test and inspection

- (1) All castings are to be cleaned and adequately prepared for examination. The surfaces are not to be hammered, peened or treated in any way which may obscure defects.
- (2) For grey iron castings, testing and inspection may not require the presence of the Society's surveyors, except where specially specified in connection with the design.
- (3) For the steel propeller castings and spheroidal iron castings, testing and inspection may require the presence of the Society's surveyor.
- (4) When required by the relevant construction Rules, castings are to be pressure tested before final acceptance.
- (5) Unless otherwise agreed, the verification of dimensions is the responsibility of the manufacturer.
- (6) Supplementary examination of castings by suitable nondestructive testing procedures is generally not required except in circumstances where there is reason to suspect the soundness of the casting.

## 8. Rectification of defective casting

- (1) At the discretion of the Surveyor, small surface blemishes may be removed by local grinding.
- (2) Subject to the prior approval of the Surveyor, castings containing local porosity may be rectified by impregnation with a suitable plastic filler, provided that the extent of the porosity is such that it does not adversely affect the strength of the casting.
- (3) Repairs by welding are generally not permitted.

**9. Retest procedure** Where the tensile test fails to meet the requirements, additional test may be carried out in accordance with the requirements of **109**.

**10. Marking** Grey iron castings which have satisfactorily complied with the required tests are to be marked with the identification mark in accordance with the requirements in **110**.

#### **11. Test certificates (2017)**

The manufacturer is to provide the Surveyor with a test certificate giving the following particulars for each casting or batch of castings which has been accepted:

- (1) Purchaser's name and order number
- (2) Description of castings and quality of cast iron
- (3) Identification number
- (4) Results of mechanical tests
- (5) Where applicable, general details of heat treatment
- (6) When specially required, the chemical analysis of ladle samples
- (7) Where applicable, test pressure

### **507. Spheroidal or nodular graphite iron castings**

#### **1. Application**

- (1) These requirements are to apply to the Spheroidal or nodular graphite iron castings (hereinafter referred to as "iron castings") intended to be used for propeller or important parts of machinery.
- (2) These requirements are applicable only to castings where the design and acceptance tests are related to mechanical properties at ambient temperature. For other applications additional requirements may be necessary, especially when the castings are intended for service at low or elevated temperatures. **【See Guidance】**
- (3) Where deemed necessary by the Society, KS or equivalent thereto may be applied. **【See Guidance】**
- (4) Where small castings are produced in large quantities, the manufacturer may adopt alternative procedures for testing and inspection subject to the approval of the Society.

#### **2. Manufacture**

- (1) The manufacturer has the necessary manufacturing and testing facilities and the manufacturing processes are to be approved by the Society.
- (2) Suitable mechanical methods are to be employed for the removal of surplus material from castings. Thermal cutting processes are not acceptable, except as a preliminary operation to mechanical methods.
- (3) Where castings of the same type are regularly produced in quantity, the manufacturer, subject to the approval of the Society, is to make any tests necessary to prove the quality of the prototype castings and is also to make periodical examinations to verify the continued efficiency of the manufacturing technique. The Surveyor is to be given the opportunity to witness these tests.

**3. Grade and mechanical properties** Grade and mechanical properties of castings are to be as specified in **Table 2.1.85**. However, Brinell hardness values are intended for information purposes only.

**Table 2.1.85 Grade and mechanical properties**

Specified min. tensile strength (N/mm <sup>2</sup> )		0.2% proof stress (N/mm <sup>2</sup> )	Elongation (%) (5.65√A)	Brinell hardness values	Impact energy		Typical structure of matrix
					Test temp.(°C)	kV <sup>(2)</sup> (J) min	
Ordinary qualities	370 min.	230 min.	17 min.	120-180	-	-	Ferrite
	400 min.	250 min.	12 min.	140-200	-	-	Ferrite
	500 min.	320 min.	7 min.	170-240	-	-	Ferrite/Perlite
	600 min.	370 min.	3 min.	190-270	-	-	Ferrite/Perlite
	700 min.	420 min.	2 min.	230-300	-	-	Perlite
	800 min.	480 min.	2 min.	250-350	-	-	Perlite or Tempered
Special qualities	350 min.	220 min.	22 min. <sup>(3)</sup>	110-170	+20	17(14)	Ferrite
	400 min.	250 min.	18 min. <sup>(3)</sup>	140-200	+20	14(11)	Ferrite

NOTE

(1) For intermediate values of specified minimum tensile strength, the minimum values for 0,2 % proof and elongation may be obtained by interpolation.

(2) The average value measured on 3 Charpy V-notch specimens. One result may be below the average value but not less than the minimum shown in brackets.

(3) In the case of integrally cast samples, the elongation may be 2 percentage points less.

#### 4. Chemical composition

- (1) The chemical composition of the iron used is left to the discretion of the manufacturer, who is to ensure that it is suitable to obtain the mechanical properties specified for the castings.
- (2) When required by the Societies the chemical composition of ladle samples is to be reported.

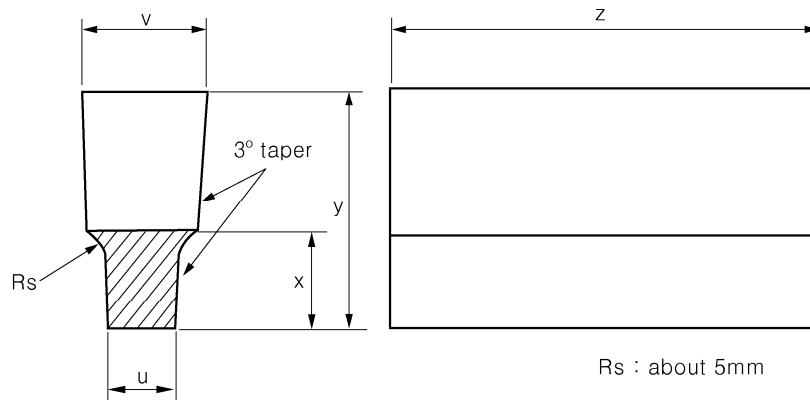
#### 5. Heat treatment

- (1) Except as required by (2) castings may be supplied in either the as cast or heat treated condition.
- (2) For some applications, such as high temperature service or where dimensional stability is important, castings may require to be given a suitable tempering or stress relieving heat treatment
- (3) Heat treatment is to be carried out after any refining heat treatment and before machining. The special qualities with 350 N/mm<sup>2</sup> and 400 N/mm<sup>2</sup> nominal tensile strength and impact test shall undergo a ferritizing heat treatment.
- (4) Where it is proposed to locally harden the surfaces of a spheroidal iron castings full details of the proposed procedure and specification are to be submitted for approval by the Society.

#### 6. Selection of test samples and specimens

- (1) Test material sufficient for the required tests and for possible re-tests is to be provided for each casting or batch of castings.
- (2) The test samples are generally to be one of the standard types detailed in **Figs 2.1.15, 2.1.16 and 2.1.17** with a thickness of 25 mm. Test samples of other dimensions, as detailed in **Figs 2.1.15 or 2.1.17** may, however, be specially required for some components.
- (3) At least one test sample is to be provided for each casting and unless otherwise required may be either gated to the casting or separately cast. Alternatively test material of other suitable dimensions may be provided integral with the casting.
- (4) Where separately cast test samples are used, they are to be cast in moulds made from the same type of material as used for the castings and are to be taken towards the end of pouring of the castings.
- (5) The samples are not to be stripped from the moulds until the temperature is below 500°C.
- (6) For large castings where more than one ladle of treated metal is used, additional test samples are to be provided so as to be representative of each ladle used.
- (7) As an alternative to (3) above, a batch testing procedure may be adopted for castings with a fettled mass of 1 tonne or less. All castings in a batch are to be of similar type and dimensions, cast from the same ladle of treated metal. One separately cast test sample is to be

- provided for each multiple of 2,0 tonnes of fettled castings in the batch.
- (8) All test samples are to be suitably marked to identify them with the castings which they represent.
  - (9) Where castings are supplied in the heat treated condition, the test samples are to be heat treated together with the castings which they represent.
  - (10) One tensile test specimen is to be prepared from each test sample.
  - (11) All tensile tests are to be carried out using test procedures in accordance with the requirements specified in **203. 1**. Unless otherwise agreed all tests are to be carried out in the presence of the Surveyors.
  - (12) Impact tests may additionally be required and in such cases a set of three test specimens of agreed type is to be prepared from each sample. Where Charpy V-notch test specimens are used, the dimensions and testing procedures are to be in accordance with the requirements specified in **202. 3** and **203. 2**.



	Standard sample	Alternative sample when specially required		
		Case 1	Case 2	Case 3
u(mm)	25	12	50	75
v(mm)	55	41	90	125
x(mm)	40	30	60	65
y(mm)	100	80	150	165
z	To suit testing machine			

Fig 2.1.15 U-type test sample

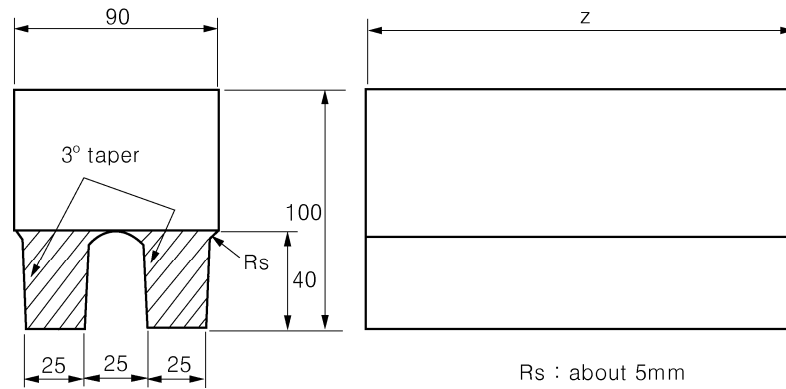
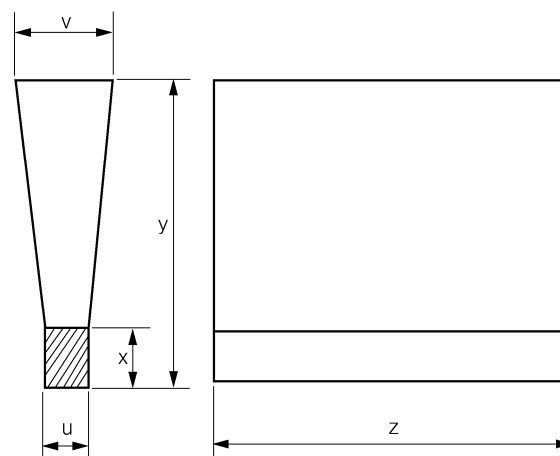


Fig 2.1.16 Double U-type test sample



	Standard sample	Alternative sample when specially required		
		Case 1	Case 2	Case 3
u(mm)	25	12	50	75
v(mm)	55	40	100	125
x(mm)	40	25	50	65
y(mm)	140	135	150	175
z	To suit testing machine			

Fig 2.1.17 Y-type test sample

## 7. Test and inspection

- (1) All castings are to be cleaned and adequately prepared for examination. The surfaces are not to be hammered, peened or treated in any way which may obscure defects.
- (2) Before acceptance, all castings are to be visually examined including, where applicable, the examination of internal surfaces. Unless otherwise agreed the verification of dimensions is the responsibility of the manufacturer.
- (3) When required by the relevant construction Rules, castings are to be pressure tested before final acceptance.
- (4) Supplementary examination of castings by suitable nondestructive testing procedures is generally not required except in circumstances where there is reason to suspect the soundness of the casting. However, cast crankshaft are to be subjected to a magnetic particle inspection. Crack like indications are not allowed.

- (5) For crankshafts the metallographic examination is to be carried out as followings;
- (a) When required, a representative sample from each ladle of treated metal is to be prepared for metallographic examination. These samples may conveniently be taken from the tensile test specimens but alternative arrangements for the provision of the samples may be adopted provided that they are taken from the ladle towards the end of the casting period.
  - (b) Examination of the samples is to show that at least 90% of the graphite is in a dispersed spheroidal or nodular form. Details of typical matrix structures are given in **Table 2.1.85** and are intended for information purposes only.

#### **8. Rectification of defective casting**

- (1) At the discretion of the Surveyor, small surface blemishes may be removed by local grinding.
- (2) Subject to the prior approval of the Surveyor, castings containing local porosity may be rectified by impregnation with a suitable plastic filler, provided that the extent of the porosity is such that it does not adversely affect the strength of the casting.
- (3) Repairs by welding are generally not permitted.

**9. Retest procedure** Where the tensile test fails to meet the requirements, additional test may be carried out in accordance with the requirements of **109**.

**10. Marking** Spheroidal iron castings which have satisfactorily complied with the required tests are to be marked with the identification mark in accordance with the requirements in **110**.

#### **11. Test certificates (2017)**

The manufacturer is to provide the Surveyor with a test certificate giving the following particulars for each casting or batch of castings which has been accepted:

- (1) Purchaser's name and order number
- (2) Description of castings and quality of cast iron
- (3) Identification number
- (4) Results of mechanical tests
- (5) Where applicable, general details of heat treatment
- (6) Where specifically required, the chemical analysis of ladle samples
- (7) Where applicable, test pressure

## Section 6 Steel Forgings

### 601. Steel forgings

#### 1. Application

- (1) The requirements in **601.** are to apply to the steel forgings(except those specified in **602., 603.** and **604.**) intended to be used for the components of hull construction, equipments, and machinery specified in each Part, and where relevant, these requirements are also applicable to material for forging stock and to rolled bars intended to be machined into components of simple shape (hereinafter referred to as the "**steel forgings**").
- (2) Steel forgings having characteristics differing from those specified in **601.** are to comply with the requirements in **101. 2.**

**2. Kinds** The steel forgings are classified as specified in **Table 2.1.89** and **2.1.90.**

#### 3. Manufacturing process

- (1) Steel forgings are to be manufactured from the killed steel.
- (2) Adequate discards are to be made from the top and bottom of each ingot to ensure freedom from piping and harmful segregation in the finished forgings.
- (3) Steel forgings are to be hot worked by press or hammer from ingots, blooms forged or rolled from ingots or blooms made from ingots by a combination of rolling and forging.
- (4) Steel forgings are to be gradually and uniformly hot worked and are to be brought as nearly as possible to the finished shape and size. Where practicable, they are to be worked so as to cause metal flow in the most favourable direction having regard to the mode of stressing in service.
- (5) The reduction ratio is to comply with the following:
  - (a) For components where the fibre deformation is mainly longitudinal; the total reduction ratio is to be not less than those shown in **Table 2.1.86.** **【See Guidance】**

**Table 2.1.86 Reduction Ratio**

Method of manufacture	Description <sup>(1)</sup>	Total reduction <sup>(2)(3)</sup>
Made directly from ingots or from forged blooms or billets	L > D	3 : 1
	L ≤ D	1.5 : 1
Made from rolled products	L > D	4 : 1
	L ≤ D	2 : 1

NOTES:

- (1) L and D are the length and diameter respectively of the part of the forging under consideration.
- (2) The reduction ratio is to be calculated with reference to the average cross-sectional area of the ingot. Where an ingot is initially upset, this reference area may be taken as the average cross-sectional area after this operation.
- (3) For rolled bars used as a substitute for forgings the reduction ratio is to be not less than 6:1.

- (b) *Disc type forgings such as gear wheels are made by upsetting*
  - (i) The thickness of any part of the disc is to be not more than one half of the length of the billet from which it was formed provided that this billet has received an initial forging reduction of not less than 1.5:1.
  - (ii) Where the piece used has been cut directly from an ingot or where the billet has received an initial reduction of less than 1.5:1, the thickness of any part of the disc is to be not more than one third of the length of the original piece.
- (6) The shaping of forgings or rolled slabs and billets by flame cutting, scarfing or arc-air gouging is to be undertaken in accordance with recognized good practice and, unless otherwise approved, is to be carried out before the final heat treatment. Preheating is to be employed when necessitated by the composition and thickness of the steel. For certain components, subsequent machining of all flame cut surfaces may be required. **【See Guidance】**
- (7) When two or more forgings are joined by welding to form a composite component, the pro-

- posed welding procedure specification is to be submitted for approval to the Society. Welding procedure qualification tests and welder qualification test are to be required. (2023)
- (8) The welding procedure qualification test and welder qualification test are in accordance with **Pt 2, Ch 2** of the Rules. (2023)

#### 4. Heat treatment

- (1) Except as provided in (5) and (6), after completion of all hot working operations, forgings are to be supplied in one of the conditions given in **Table 2.1.87**. to refine the grain structure and to obtain the required mechanical properties. No fully annealed forging is to be removed from the furnace until the temperature of the entire furnace charge has fallen to or below a temperature of 455°C. The tempering temperature is to be not less than 550°C. Where forgings for gearing are not intended for surface hardening, lower tempering temperature may be allowed. (2023)  
**[See Guidance]**

**Table 2.1.87 Heat Treatment (2023)**

Kind	Heat treatment
Carbon steels	Fully Annealed Normalized Normalized and tempered Quenched and tempered
Alloy steels	Normalized Normalized and tempered Quenched and tempered

- (2) The delivery condition shall meet the design and application requirements, it is the manufacturers responsibility to select the appropriate heat treatment method to obtain the required mechanical properties. (2023)
- (3) Steel forgings which are subjected to any hot work after heat treatment, are to be heat treated again.
- (4) If a forging is locally reheated or any straightening operation is performed after the final heat treatment, consideration is to be given to a subsequent stress relieving heat treatment. The manufacturer shall have strict control of this temperature in order to avoid any detrimental effects to the final heat treatment and resultant microstructure and mechanical properties of the forging. (2023)
- (5) Where induction hardening or nitriding is to be carried out, forgings are to be heat treated at an appropriate stage to a condition suitable for this subsequent surface hardening.
- (6) Where carburizing is to be carried out, forgings are to be heat treated at an appropriate stage (generally either by full annealing or by normalizing and tempering) to a condition suitable for subsequent machining and carburizing.
- (7) Where it is intended to surface harden forgings, full details of the proposed procedure and specification are to be submitted for the approval of the Society. For the purposes of this approval, the manufacture may be required to demonstrate by test that the proposed procedure gives a uniform surface layer of the required hardness and depth and that it does not impair the soundness and properties of the steel. **[See Guidance]**
- (8) Heat treatment is to be carried out in properly constructed furnaces which are efficiently maintained and have adequate means for control and recording of temperature. The furnace dimensions are to be such as to allow the whole furnace charge to be uniformly heated to the necessary temperature. In the case of very large forgings alternative methods of heat treatment will be specially considered by the Society.  
Sufficient thermocouples are to be connected to the furnace charge to measure and record that its temperature is adequately uniform unless the temperature uniformity of the furnace is verified at regular intervals.
- (9) The forge is to maintain records of heat treatment identifying the furnace used, furnace charge, date, temperature and time at temperature. The records are to be presented to the surveyor on request.



### 5. Chemical composition

- (1) The chemical composition of steel forgings is to comply with the requirements given in **Table 2.1.88**.
- (2) The chemical composition of each heat is to be determined by the manufacturer on a sample taken preferably during the pouring of the heat. When multi heats are tapped into a common ladle, the ladle analysis shall apply.
- (3) At the option of the manufacturer, suitable grain refining elements such as aluminium, niobium or vanadium may be added. The content of such elements is to be reported in the ladle analysis.

**Table 2.1.88 Chemical Composition (2017) (2021) (2023)**

Steel type		Chemical composition (%)									
		C	Si	Mn	P	S	Cr	Mo	Ni	Cu <sup>(3)</sup>	Total residual
Hull and General purpose steel forging <sup>(4)</sup>	Carbon steel	0.23 <sup>(1)(2)</sup> max.	0.45 max.	0.30–1.50	0.035 max.	0.035 max.	0.30 <sup>(3)</sup> max.	0.15 <sup>(3)</sup> max.	0.40 <sup>(3)</sup> max.	0.30 max.	0.85 max.
	Alloy steel	0.23 max.	0.45 max.	0.30–1.00	0.035 max.	0.035 max.	0.40 <sup>(6)</sup> min.	0.15 <sup>(6)</sup> min.	0.40 <sup>(6)</sup> min.	0.30 max.	–
Machinery steel forging	Carbon steel	0.23 <sup>(1)(2)</sup> max.	0.45 max.	0.30–1.50	0.035 max.	0.035 max.	0.30 <sup>(3)</sup> max.	0.15 <sup>(3)</sup> max.	0.40 <sup>(3)</sup> max.	0.30 max.	0.85 max.
	Alloy steel <sup>(5)</sup>	0.45 max.	0.45 max.	0.30–1.00	0.035 max.	0.035 max.	0.40 <sup>(6)</sup> min.	0.15 <sup>(6)</sup> min.	0.40 <sup>(6)</sup> min.	0.30 max.	–

NOTES :

- (1) The carbon content may be increased above this level provided that the carbon equivalent (Ceq) is not more than 0.41 %.
- (2) The carbon content of carbon steel forgings not intended for welded construction may be 0.65 % maximum.
- (3) Elements are considered as residual elements.
- (4) Rudder stocks and pintles should be of weldable quality.
- (5) Where alloy steel forgings are intended for welded constructions, the proposed chemical composition is subject to approval by the Society.
- (6) One or more of the elements is to comply with the minimum content.

### 6. Mechanical properties

- (1) The mechanical properties of steel forgings are to comply with the requirements given in **Table 2.1.89** and **2.1.90**.
- (2) At the discretion of this Societies hardness tests may be required on the following: The results of hardness tests are to be reported and, for information purposes, typical Brinell hardness values are given in **Table 2.1.90**.
  - (i) Gear forgings after completion of heat treatment and prior to machining the gear teeth. The hardness is to be determined at four positions equally spaced around the circumference of the surface where teeth will subsequently be cut. Where the finished diameter of the toothed portion exceeds 2.5 m, the above number of test positions is to be increased to eight. Where the width of a gear wheel rim forging exceeds 1.25 m, the hardness is to be determined at eight positions at each end of the forging.
  - (ii) Small crankshaft and gear forgings which have been batch tested.  
In such cases at least one hardness test is to be carried out on each forging.
- (3) Hardness tests may also be required on forgings which have been induction hardened, nitrided or carburized. For gear forgings these tests are to be carried out on the teeth after, where applicable, they have been ground to the finished profile. The results of such tests are to comply with the approved specifications.

### 7. Selection of test specimens

- (1) Except as provided in (10) and (11), the test specimens for steel forgings are, after final heat treatment, to be taken lengthwise from prolongations or through bolt holes having a sectional area not less than that of the body of forging. Where batch testing is permitted according to (10), the test material may alternatively be a production part or separately forged. Separately forged test material is to have a reduction ratio similar to that used for the forgings represented.
- (2) "One set of test specimens" is to consist of one tensile test specimen and when required, three charpy-V notch impact test specimen.

Table 2.1.89 Kinds and Mechanical Properties for Hull Steel Forgings (2017) (2023)

Steel type	grades	Tensile test						Charpy V-notch impact test <sup>(6)</sup>		
		Tensile strength (N/mm <sup>2</sup> )	Yield strength (N/mm <sup>2</sup> )	Elongation(%) ( $L = 5.65\sqrt{A}$ ) (minimum)		Reduction of area(%) (minimum)		Test temperature(°C)	Minimum average energy(J)	
				L	T	L	T		L <sup>(4)</sup>	T <sup>(4)</sup>
Carbon steel forgings	RSF400H	400 min.	200 min.	26	19	50	35	0	27	18
	RSF440H	440 min.	220 min.	24	18	50	35			
	RSF480H	480 min.	240 min.	22	16	45	30			
	RSF520H	520 min.	260 min.	21	15	45	30			
	RSF560H	560 min.	280 min.	20	14	40	27			
	RSF600H	600 min.	300 min.	18	13	40	27			
Alloy steel forgings	RSF550AH	550 min.	350 min.	20	14	50	35	0	27	18
	RSF600AH	600 min.	400 min.	18	13	50	35			
	RSF650AH	650 min.	450 min.	17	12	50	35			

Notes ;

- (1) Where it is proposed to use a steel with a specified minimum tensile strength intermediate to those given, corresponding minimum values for the other properties may be obtained by interpolation and the value at the first decimal place is to be subjected to the method of counting fractions over 1/2 as one and disregarding the rest.
- (2) For the upper limit of tensile strength, the following ranges for tensile strength may be additionally specified:

Specified minimum tensile strength (N/mm <sup>2</sup> )	Range of upper limit(N/mm <sup>2</sup> )
< 600	120
≥ 600	150

- (3) In the case of large forgings requiring two tension tests, the range of tensile strength is not to exceed 70 N/mm<sup>2</sup>
- (4) L (or T) denotes that the longitudinal axis of the test specimen is arranged parallel (or tangential) to the direction of forging.
- (5) For rudder stocks intended for ships with ice class notation(Grade IA Super, IA, IB and IC), Charpy V-notch impact testing is to be carried out for all steel types at -10°C and the average energy value is to be minimum 27 J (longitudinal test).
- (6) Special consideration may be given to alternative requirements for Charpy V-notch test, depending on design and application and subject to agreement by the Society.

Table 2.1.90 Kinds and mechanical properties for machinery steel forgings (2017) (2023)

Steel type	Grades	Tensile test						Hardness test <sup>(5)</sup>	Charpy V-notch impact test <sup>(4)(6)</sup>		
		Tensile strength <sup>(2)</sup> (N/mm <sup>2</sup> )	Yield strength (N/mm <sup>2</sup> )	Elongation(%) ( $L = 5.65\sqrt{A}$ ) (minimum)		Reduction of area(%) (minimum)		Hardness (H <sub>BW</sub> )	Test temperature(°C)	Minimum average energy(J)	
				L <sup>(3)</sup>	T <sup>(3)</sup>	L <sup>(3)</sup>	T <sup>(3)</sup>			L <sup>(3)</sup>	T <sup>(3)</sup>
Carbon steel forgings	<i>RSF 400M</i>	400 min.	200 min.	26	19	50	35	110 – 150	AT <sup>(7)</sup>	27	18
	<i>RSF 440M</i>	440 min.	220 min.	24	18	50	35	125 – 160			
	<i>RSF 480M</i>	480 min.	240 min.	22	16	45	30	135 – 175			
	<i>RSF 520M</i>	520 min.	260 min.	21	15	45	30	150 – 185			
	<i>RSF 560M</i>	560 min.	280 min.	20	14	40	27	160 – 200			
	<i>RSF 600M</i>	600 min.	300 min.	18	13	40	27	175 – 215			
	<i>RSF 640M</i>	640 min.	320 min.	17	12	35	27	185 – 230			
	<i>RSF 680M</i>	680 min.	340 min.	16	12	35	24	200 – 240			
	<i>RSF 720M</i>	720 min.	360 min.	15	11	35	24	210 – 250			
	<i>RSF 760M</i>	760 min.	380 min.	14	10	35	24	225 – 265			
Alloy steel forgings	<i>RSF 600AM</i>	600 min.	360 min.	18	14	50	35	175 – 215			
	<i>RSF 700AM</i>	700 min.	420 min.	16	12	45	30	205 – 245			
	<i>RSF 800AM</i>	800 min.	480 min.	14	10	40	27	235 – 275			
	<i>RSF 900AM</i>	900 min.	630 min.	13	9	40	27	260 – 320			
	<i>RSF 1000AM</i>	1000 min.	700 min.	12	8	35	24	290 – 365			
	<i>RSF 1100AM</i>	1100 min.	770 min.	11	7	35	24	320 – 385			

Table 2.1.90 Kinds and mechanical properties for machinery steel forgings(cont'd) (2017) (2023)

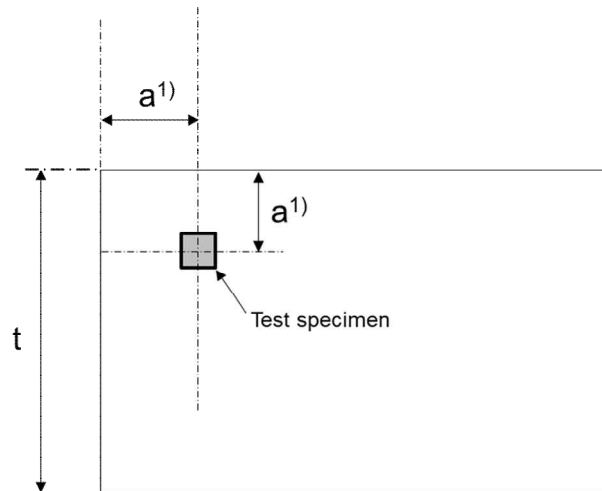
NOTES :

- (1) Where it is proposed to use a steel with a specified minimum tensile strength intermediate to those given, corresponding minimum values for the other properties may be obtained by interpolation and the value at the first decimal place is to be subjected to the method of counting fractions over 1/2 as one and disregarding the rest.
- (2) For the upper limit of tensile strength, the following ranges for tensile strength may be additionally specified:

Specified minimum tensile strength (N/mm <sup>2</sup> )	Range of upper limit (N/mm <sup>2</sup> )
< 900	150
≥ 900	200

- (3) L (or 7) denotes that the longitudinal axis of the test specimen is arranged parallel (or tangential) to the direction of forging.
- (4) For materials used for machinery exposed to sea water temperature, such as propeller shafts and shaft bolts, intended for ships with ice class notation(Grade IA Super, IA, IB and IC), Charpy V-notch impact testing is to be carried out for all steel types at -10 °C and the average energy value is to be minimum 20 J (longitudinal test). One individual value may be less than the required average value provided that it is not less than 70% of this average value. Impact test for important components as crankshaft and gears for machinery is to be in accordance with the Guidance relating to the Rules specified by the Society.  
**【See Guidance】**
- (5) The hardness values are typical and are given for information purposes only.
- (6) Special consideration may be given to alternative requirements for Charpy V-notch test, depending on design and application and subject to agreement by the Society.
- (7) AT refers to Ambient Temperature (i.e. 23°C ± 5°C), which is specified in **ISO 148-1:2016**.

- (3) Test specimens are normally to be cut with their axes either mainly parallel (longitudinal test) or mainly tangential (tangential test) to the principal axial direction of each product.
- (4) The test specimen is to be positioned as follows. (2023)
  - (A) For forgings having a thickness, t, or diameter D up to maximum 50 mm, the longitudinal axis of the test specimen is to be located at a distance of t/2 or D/2 below the heat treated surfaces.
  - (B) For forgings having a thickness, t, or diameter D greater than 50 mm, the longitudinal axis of the test specimen is to be located at a distance of t/4 or D/4 (mid-radius) or 80mm, whichever is less, below any heat treated surface. Test specimen is to be located with its longitudinal axis at a distance from any heat treated surface as shown in **Fig 2.1.18**.
  - (C) For ring and disc forgings (noting that the test specimen locations for these shaped forgings may be different to elongated or free form forgings), tangential sample shall be taken at t/2 for thickness ≤ 25mm and 12.5 mm below the surface for thickness >25 mm, in both the vertical and horizontal direction. Where achievable, for thickness >25 mm, no part of the test material shall be closer than 12.5 mm to any heat treated surface, as shown in **Fig 2.1.18**.



(Notes)

- (1) "a" is the distance from the test specimen to heat treated surface based on the above (B) or (C).

Fig 2.1.18 Position of the test specimen (2023)

- (5) Where the manufacturer can demonstrate that a proposed testing location or orientation is more representative of the required mechanical properties of a component, this may be agreed with the Society. In such cases, the heat treatment process, a proposed testing location or orientation, and technical justification shall be submitted to the Society for approval.
- (6) Except as provided in (11), the number and direction of tests is to be as given in (A) through (I) of the following requirements:
- (A) *Hull components such as rudder stocks, pintles etc. General machinery components such as shafting, connecting rods, etc.* : One set of tests is to be taken from the end of each forging in a longitudinal direction except that, at the discretion of the manufacture, the alternative directions or positions as shown in Fig 2.1.19, Fig 2.1.20 and Fig 2.1.21 may be used. Where a forging exceeds both 4 tonnes in mass and 3 m in length, one set of tests is to be taken from each end.

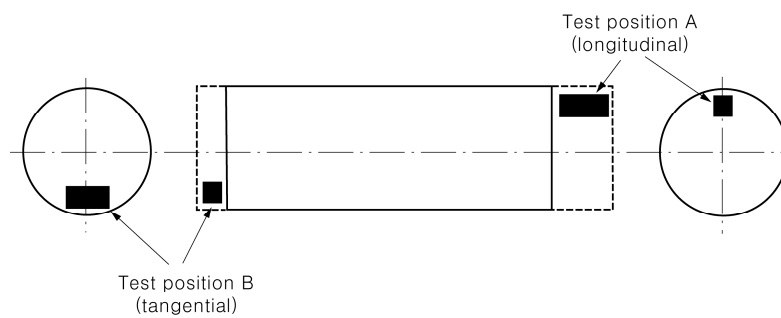


Fig 2.1.19 Plain shaft

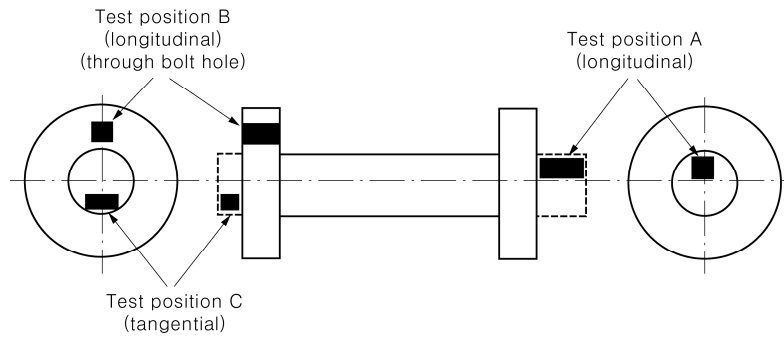


Fig 2.1.20 Flanged shaft

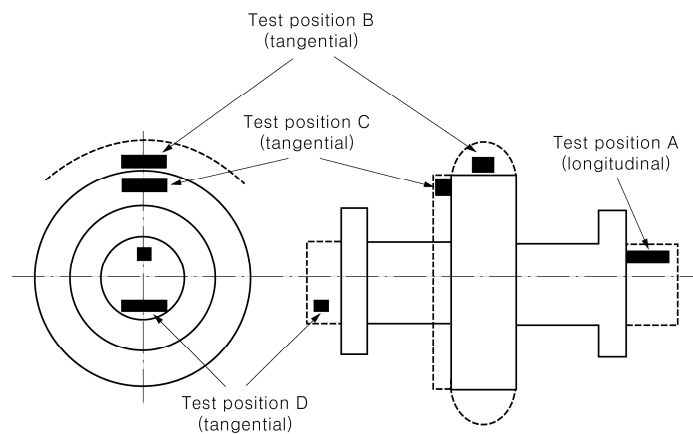


Fig 2.1.21 Flanged shaft with collar

- (B) *Pinions* : Where the finished machined diameter of the toothed portion exceeds 200 mm one set of tests is to be taken from each forging in a tangential direction adjacent to the toothed portion (test position B in Fig 2.1.22) Where the dimensions preclude the preparation of tests from this position, tests in a tangential direction are to be taken from the end of the journal (test position C in Fig 2.1.22). If however, the journal diameter is 200 mm or less the tests are to be taken in a longitudinal direction (test position A in Fig 2.1.22). Where the finished length of the toothed portion exceed 1.25 m, one set of tests is to be taken from each end.

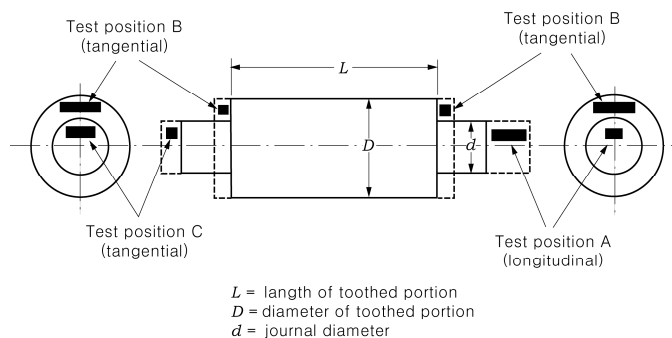


Fig 2.1.22 Pinion

- (C) *Small pinions* : Where the finished diameter of the toothed portion is 200 mm or less one set of tests is to be taken in a longitudinal direction (test position A in Fig 2.1.22).  
 (D) *Gear wheels* : One set of tests is to be taken from each forging in a tangential direction (test position A or B in Fig 2.1.23).

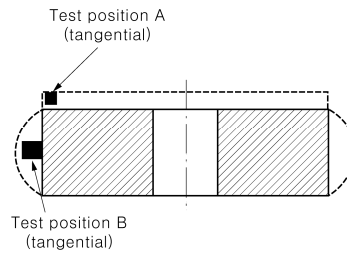


Fig 2.1.23 Gear wheel

- (E) Rims intended for reduction gears and for cam shaft driving gears of diesel engine (see Pt 5, Ch 2 201.1) are to comply with the following requirements.
- (i) Where the finished diameter exceeds 2.5 m or the mass (as heat treated including test material) exceeds 3 tonnes, two sets of tests are to be taken from diametrically opposite positions (test positions A and B in Fig 2.1.24). The mechanical properties for longitudinal test are to be applied. (2023)

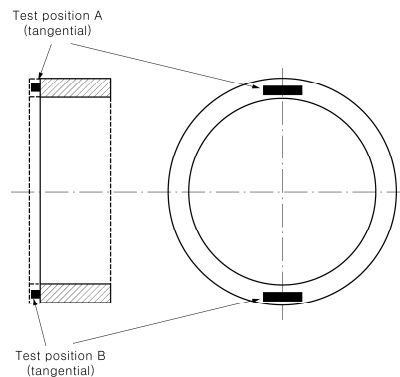


Fig 2.1.24 Gear rim (made by expanding)

- (ii) Where the weight and finished diameter are different from those given in (a), one set of test specimens may be taken from one end of the rim.
- (F) *Pinion sleeves* : One set of tests is to be taken from each forging in a tangential direction (test position A or B in Fig 2.1.25). Where the finished length exceeds 1.25 m one set of tests is to be taken from each end.

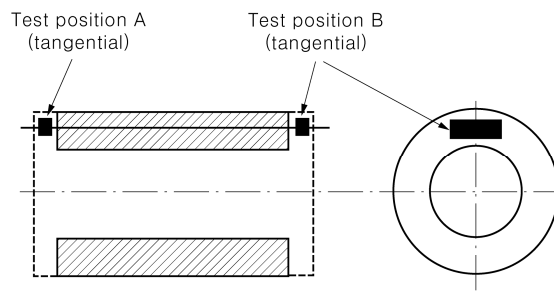


Fig 2.1.25 Pinion sleeve

- (G) *Crankwebs* : One set of tests is to be taken from each forging in a tangential direction.
- (H) *Solid open die forged crankshafts* : One set of tests is to be taken in a longitudinal direction from the driving shaft end of each forging (test position A in Fig 2.1.26). Where the mass (as heat treated but excluding test material) exceeds 3 tonnes tests in a longitudinal direction are to be taken from each end (test positions A and B in Fig 2.1.26). Where, however, the crankthrows are formed by machining or flame cutting, the second set of



tests is to be taken in a tangential direction from material removed from the crankthrow at the end opposite the driving shaft end (test position C in Fig 2.1.26).

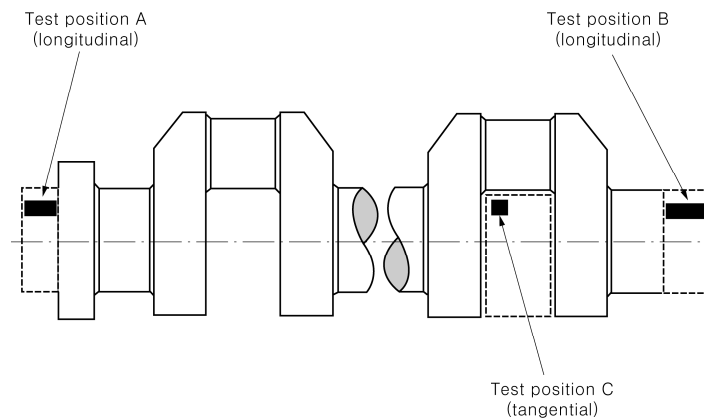


Fig 2.1.26 Solid forged crankshaft

- (l) Forged Rings (such as slewing rings) : One set of tests is to be taken from each forging in a tangential direction (test positions are shown in Fig 2.1.27). Where the finished diameter exceeds 2.5 m or the mass (as heat treated, including test material) exceeds 3 tonnes then two sets of tests are to be taken diametrically opposite positions. (2023)

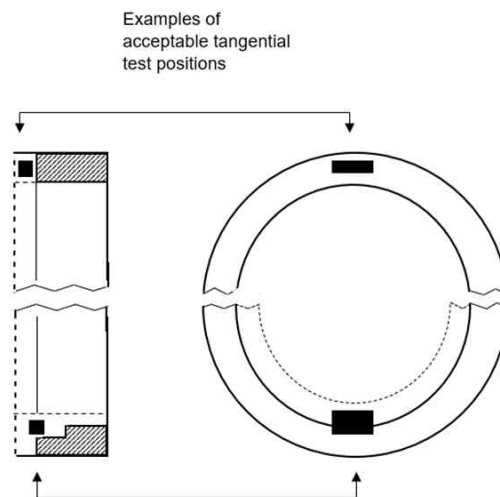


Fig 2.1.27 Forged rings (2023)

- (7) For closed die crankshaft forgings and crankshaft forgings where the method of manufacture has been approved by the Society, the number and position of test specimens is to be agreed with the Society having regard to the method of manufacture employed.
- (8) When a forging is subsequently divided into a number of components, all of which are heat treated together in the same furnace charge, for test purposes this may be regarded as one forging and the number of tests required is to be related to the total length and mass of the original multiple forging.
- (9) The test specimens are not to be separated from the body before the final heat treatment has been completed. In the case of stamp forging or other case of forging requiring the surface hardening process, the test specimens may be prepared at a proper stage before the final heat treatment providing that such is approved by the Surveyor.
- (10) When forgings are to be carburized, sufficient test material is to be provided for both prelimi-

nary tests at the forge and for final tests after completion of carburizing. For this purpose duplicate sets of test material are to be taken from positions as detailed in (5) except that irrespective of the dimensions or mass of the forging, tests are required from one position only and, in the case of forgings with integral journals, are to be cut in a longitudinal direction. This test material is to be machined to a diameter of  $D/4$  or 60 mm, whichever is less, where  $D$  is the finished diameter of the toothed portion. For preliminary tests at the forge one set of test material is to be given a blank carburizing and heat treatment cycle simulating that which subsequently will be applied to the forging. For final acceptance tests, the second set of test material is to be blank carburized and heat treated along with the forgings which they represent. At the discretion of the forgemaster or gear manufacture test samples of larger cross section may be either carburized or blank carburized, but these are to be machined to the required diameter prior to the final quenching and tempering heat treatment. Alternative procedures for testing of forgings which are to be carburized may be specially agreed with the Society. **【See Guidance】**

- (11) Normalized forgings with mass up to 1000 kg each and quenched and tempered forgings with mass up to 500 kg each may be batch tested. A batch is to consist of forgings of similar shape and dimensions, made from the same heat of steel, heat treated in the same furnace charge and with a total mass not exceeding 6 tonnes for normalized forgings and 3 tonnes for quenched and tempered forgings, respectively.
- (12) A batch testing procedure may also be used for hot rolled bars. A batch is to consist of either:
  - (i) material from the same rolled ingot or bloom provided that where this is cut into individual lengths, these are all heat treated in the same furnace charge, or
  - (ii) bars of the same diameter and heat, heat treated in the same furnace charge and with a total mass not exceeding 2.5 tonnes.

#### 8. Surface inspection **【See Guidance】**

- (1) All forgings should be subjected to a 100% visual examination of all accessible surfaces by the manufacturer and made available to the Surveyor. Where applicable, this visual examination is to include the examination of internal surfaces and bores. Testing methods and acceptance criteria are to be in accordance with the Guidance relating to the Rules specified by the Society. (2023)
- (2) Dimension inspection of the steel forgings is to be conducted under the responsibility of the manufacturer, unless otherwise specified.

#### 9. Quality

- (1) Steel forgings are to be free from surface or internal defects which would be prejudicial to their proper application in service.
- (2) When required by the conditions of approval for surface hardened forgings referred in 4 (7), additional test samples are to be processed at the same time as the forgings which they represent. These test samples are subsequently to be sectioned in order to determine the hardness, shape and depth of the locally hardened zone and which are to comply with the requirements of the approved specification.
- (3) In the event of any forging proving defective during subsequent machining or testing, it is to be rejected notwithstanding any previous certification.

#### 10. Non-destructive inspection

- (1) The following steel forgings are to be subjected to ultrasonic test at an appropriate stage of the manufacturing process and the test reports are to be showed or submitted to the Surveyor. Testing methods and acceptance criteria are to be in accordance with the Guidance relating to the Rules specified by the Society. **【See Guidance】**
  - (a) Rudder stock and pintle.
  - (b) Steel forgings given in **Pt 5, Ch 2, 201.1**.
  - (c) Thrust shafts, intermediate shafts and propeller shafts.
  - (d) Reduction gears and reduction gear shafts.
  - (e) Turbine rotors, turbine discs and turbine blades.
- (2) The important parts of the following steel forgings are to be subjected to magnetic particle or liquid penetrant test at an appropriate stage of the manufacturing process. Testing methods and acceptance criteria are to be in accordance with the Guidance relating to the Rules specified by the Society. **【See Guidance】**
  - (a) Steel forgings given in **Pt 5, Ch 2, 201.1**.
  - (b) Propeller shafts.
  - (c) Reduction gears.

- (d) Turbine rotors, turbine discs and turbine blades.
- (3) The Society may require sulphur print test for the portion of gear teeth.
- (4) In place of the test methods given above, the Society may accept the application of other non-destructive inspections considered adequate by the Society. **【See Guidance】**
- (5) The Society may require non-destructive inspection of the steel other than those specified in (1) and (2) when such is deemed necessary by the Society. **【See Guidance】**
- (6) The welded parts of steel forgings used for welded construction are to be subjected to the non-destructive inspections considered adequate by the Society. **【See Guidance】**

#### 11. Repair of defects

- (1) Defects may be removed by grinding or chipping and grinding provided the component dimensions are acceptable.
- (2) After removing the defects, adequate non-destructive inspections are to be carried out to ensure that all defects have been completely removed.
- (3) The resulting grooves are to have a bottom radius of approximately three times the groove depth and are to be blended into the surrounding surface so as to avoid any sharp contours. Where the forgings from which defects were removed are used in that condition, the forgings are to be approved by the Surveyor.
- (4) Repair welding of forgings except those subjected to torsional fatigue, such as crankshaft forgings and propeller shaft forgings, may be permitted subject to prior approval of the Society. In such cases, full details of the extent and location of the repair, the proposed welding procedure, heat treatment and subsequent inspection procedures are to be submitted for the approval. (2023) **【See Guidance】**
- (5) The manufacturer is to maintain full records detailing the extent and location of repairs made to each forging and details of weld procedures and heat treatments applied for repairs. These records are to be available to the Surveyor and copies provided on request.

#### 12. Retest procedures

- (1) Where the tensile test or hardness test fails to meet the requirements, additional test may be carried out in accordance with the requirements of **109**.
- (2) Regarding the impact tests, additional tests are to be carried out according to the requirements given in **301. 10** (3).
- (3) The additional tests are to be taken, preferably from material adjacent to the original tests, but alternatively from another test position or sample representative of the forging or batch of forgings.
- (4) At the option of the manufacturer, when a forging or a batch of forgings has failed to meet the test requirements, it may be reheat treated and re-submitted for acceptance tests.

#### 13. Marking

- (1) Steel forgings which have satisfactorily complied with the required tests are to be marked with the identification mark in accordance with the requirements in **110**. And it should also include follows. (2023)
  - (A) Test pressure where applicable
  - (B) Date of final inspection
- (2) For steel forgings to which the requirements given in note 1. of the **Table 2.1.89** and **Table 2.1.90** applied, the material symbols are specified as *RSF-* (or *RSF- A*) and the specified tensile strength is to be filled in symbol " - ". (e.g. For Hull and General purpose steel forging which the specified tensile strength is 420 N/mm<sup>2</sup> : *RSF420H*)
- (3) Where carbon steel forgings are intended for welded construction specified in Note (1) of **Table 2.1.88**, "W" is to be suffixed to the marking. (e.g. *RSF440H-W*, *RSF440M-W*)
- (4) The grade of Steel bars is to be indicated by suffixing a letter "B" to the symbol "*RSF*". (e.g. For Machinery steel forging which the specified tensile strength is 440 N/mm<sup>2</sup> : *RSFB440M*)
- (5) Where alloy steel forgings are intended for intermediate shaft material specified in **18**., "I" is to be suffixed to the marking. (e.g. *RSF900AM-I*) (2017)

#### 14. Test certificates (2017)

The manufacturer is to provide the required type of inspection certificate giving the following particulars for each forging or batch of forgings which has been accepted:

- (1) Purchaser's name and order number
- (2) Description of forgings and steel quality
- (3) Identification number

- (4) Steelmaking process, cast number and chemical analysis of ladle sample
- (5) Results of mechanical tests
- (6) Results of non-destructive tests, where applicable
- (7) Details of heat treatment, including temperature and holding times

#### 15. Additional requirements for crank shafts

- (1) Where solid crank shafts of 250 mm and over in finished diameter are manufactured by free forging, the heat treatment is normally to be carried out after crank parts are machined as nearly as possible to the finished shape. **【See Guidance】**
- (2) Where solid crank shafts, semibuilt-up crank throws and full built up crank arms are manufactured by special manufacturing processes, the preliminary tests instructed by the Society are to be carried out, in connection with the manufacturing processes and the selection of test specimens. **【See Guidance】**
- (3) Where special manufacturing processes are adopted to reduce the size of crank shaft (refer to the requirements in **Pt 5, Ch, 208**, the preliminary tests instructed by the Society are to be carried out.

#### 16. Additional requirements for turbine rotors

- (1) The test specimens for turbine rotors are to be taken in accordance with the following requirements:
  - (a) Where the turbine rotor is greater than 3 tons in weight, one set of longitudinal test specimens is to be taken from each end of the shaft portion and one set of transverse test specimens from the body portion respectively. (See **Fig 2.1.28**)
  - (b) Where the turbine rotor is not exceeding 3 tons in weight, one set of longitudinal test specimens is to be taken from one end of the shaft portion and one set of transverse test specimens from the body portion respectively.
- (2) For each turbine disc, one set of transverse test specimens is to be taken from the boss portion. (See **Fig 2.1.29**)

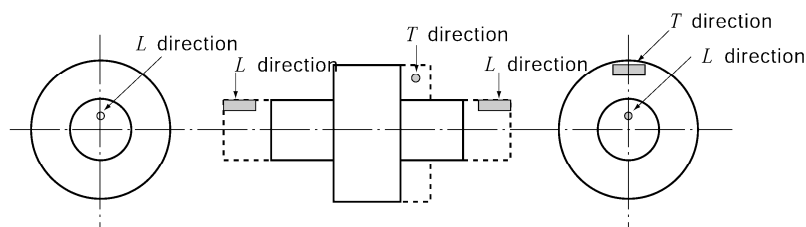
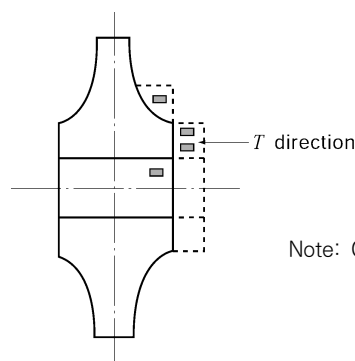


Fig 2.1.28 Selection of test specimen for turbine rotor



Note: One set of test specimens may be taken from one location given in the Figure.

Fig 2.1.29 Selection of test specimen for turbine disc

- (3) Solid forged turbine rotors intended for main propulsion service where the inlet steam temperature exceeds 400°C are to be subjected to stability tests at least once at a suitable time after rough machining or heat treatment. This requirement is also applicable to rotors fabricated by welding. The method of stability test is to be approved by the Society prior to the test.

**17. Additional requirements for turbine blades** Turbine blades are to be tested in accordance with the approved test specification.

**18. Additional requirements for intermediated shaft material (2017)**

(1) For alloy steel which has a minimum specified tensile strength greater than 800 N/mm<sup>2</sup> but less than 950 N/mm<sup>2</sup> for use as intermediate shaft material, where special manufacturing processes are adopted to reduce shaft dimensions or higher permissible vibration stresses (refer to the requirements in **Pt 5, Ch 3, 203.** and **Ch 4, 202.**) is to be as follows.

(a) Torsional fatigue test instructed by the Society is to be performed for verifying the fatigue life at manufacturing process approval.

(b) The steels are to have a degree of cleanliness as shown in **Table 2.1.91** when cleanliness tested. Representative samples are to be obtained from each heat of forged or rolled products. The steels are generally to comply with particular attention given to minimising the concentrations of sulphur, phosphorus and oxygen in order to achieve the cleanliness requirements. The specific steel composition is required to be approved by the Society.

**Table 2.1.91 Cleanliness requirements(ISO 4967:2013 method A) (2022)**

Inclusion group	Series	Limiting chart diagram index /
Type A	Fine	1 max.
	Thick	1 max.
Type B	Fine	1.5 max.
	Thick	1 max.
Type C	Fine	1 max.
	Thick	1 max.
Type D	Fine	1 max.
	Thick	1 max.
Type DS	-	1 max.

**602. Stainless steel forgings**

**1. Application**

(1) The requirements are to apply to the stainless steel forgings for valves and pipe fittings in piping systems used at low temperature (-165°C and over in design temperature) service or corrosion-resisting service (hereinafter referred to as "steel forgings").

(2) Steel forgings having characteristics differing from those specified in **602.** are to comply with the requirements in **101. 2.**

**2. Kinds** Steel forgings are classified as specified in **Table 2.1.92.**

**3. Heat treatment**

Steel forgings are generally to receive a solid solution treatment.

**4. Chemical composition**

The chemical composition of steel forgings is to comply with the requirements given in **Table 2.1.92.**

Table 2.1.92 Grade and Chemical Composition

Grade	Chemical composition (%)									
	<i>C</i>	<i>Si</i>	<i>Mn</i>	<i>P</i>	<i>S</i>	<i>Cr</i>	<i>Ni</i>	<i>Others</i>		
<i>RSSF304</i>	0.08 max.	1.00 max.	2.00 max.	0.040 max.	0.030 max.	18.00~20.00	8.00~12.00	-		
<i>RSSF304L</i>	0.030 max.									
<i>RSSF309S</i>	0.08 max.								22.00~24.00	12.00~15.00
<i>RSSF310S</i>						24.00~26.00	19.00~22.00			
<i>RSSF316</i>										
<i>RSSF316L</i>						0.030 max.	Mo 2.00~3.00			
<i>RSSF317</i>	0.08 max.					18.00~20.00	10.00~15.00		Mo 3.00~4.00	
<i>RSSF321</i>									17.00~19.00	9.00~12.00
<i>RSSF347</i>						9.00~13.00	Nb+Ta ≥ 10×C			

### 5. Mechanical properties

- (1) The mechanical properties of steel forgings are to comply with the requirements given in **Table 2.1.93**.
- (2) Where deemed necessary by the Society, impact test or corrosion resistance test may be required in addition to the specified tests.

Table 2.1.93 Mechanical Properties

Grade	Tensile test			
	Yield strength (N/mm <sup>2</sup> )	Tensile strength (N/mm <sup>2</sup> )	Elongation(%) ( $L = 5.65\sqrt{A}$ )	Reduction of area (%)
<i>RSSF304L, RSSF316L</i>	175 min.	450 min.	37 min.	50 min.
Other forgings	205 min.	520 min.	37 min.	50 min.

### 6. Selection of the specimens

- (1) The number of tensile test specimens is to be in accordance with the requirements in **601. 7**.
- (2) Tensile test specimens are to be taken with their longitudinal axes parallel to the direction of forging, unless otherwise specially provided by the Society.
- (3) Where tests are made in accordance with the requirements in **601. 7** (5), (c) and (d), the Surveyor may require hardness test for each forging.

### 7. Marking

Steel forgings which have satisfactorily complied with the required test are to be marked with the identification mark in accordance with the requirements in **110.**

## 603. Steel forgings for chains

### 1. Application

- (1) These requirements are to apply to the steel forgings used for anchor chain cables and accessories specified in **Pt 4, Ch 8** (hereinafter referred to as "steel forgings").
- (2) Steel forgings for manufacture of offshore mooring chain accessories are to be in accordance with the Guidance relating to the Rules specified by the Society. **[See Guidance]**
- (3) Steel forgings having characteristics differing from those specified in (1) are to comply with the requirements in **101. 2**.
- (4) In addition to the requirements given in **603.**, general requirements may be considered by the Society. **[See Guidance]**

## 2. Kinds

The steel forgings are classified as specified in **Table 2.1.94**.

**Table 2.1.94 Grades of Steel Forgings**

Grade		Application
Steel forging for Grade 2 chain	<i>RSFC50</i>	Grade 2 chain
Steel forging for Grade 3 chain	<i>RSFC70</i>	Grade 3 chain

## 3. Heat treatment

The steel forgings are to be normalized, normalized and tempered, quenched and tempered or heat treated by the process approved by the Society.

## 4. Deoxidation practice and chemical composition

The deoxidation practice and chemical composition of each grade are to comply with the requirements given in **Table 2.1.95**. Elements other than specified in **Table 2.1.95** may be added subject to a special approval by the Society.

**Table 2.1.95 Deoxidation Practice and Chemical Composition (%)**

Grade	Deoxidation	<i>C</i>	<i>Si</i>	<i>Mn</i>	<i>P</i>	<i>S</i>	<i>A<sub>f</sub></i> <sup>(1)</sup>
<i>RSFC50</i>	Fine-grained killed	0.24 max.	0.15~0.55	1.60 max.	0.035 max.	0.035 max.	0.020 min.
<i>RSFC70</i>		0.36 max.	0.15~0.55	1.00~1.90	0.035 max.	0.035 max.	0.020 min.

NOTE:  
(1) *A<sub>f</sub>* content is to be represented by the total *A<sub>f</sub>* content and may be replaced partly by other fine graining elements.

## 5. Mechanical properties

The mechanical properties of each grade are to comply with the requirements given in **Table 2.1.96**.

**Table 2.1.96 Mechanical Properties**

Grade	Tensile test				Impact test <sup>(1)</sup>	
	Yield strength (N/mm <sup>2</sup> ) <sup>(2)</sup>	Tensile strength (N/mm <sup>2</sup> ) <sup>(2)</sup>	Elongation (%) ( <i>L=5d</i> )	Reduction of area (%)	Test temp. (°C)	Average absorbed energy(J)
<i>RSFC50</i>	295 min.	490~690	22 min.	-	-	-
<i>RSFC70</i>	410 min.	690 min.	17 min.	40 min.	0	60 min.

NOTE:  
(1) When the absorbed energy of two or more test specimens among a set of test specimens is less in value than the specified average absorbed energy or when the absorbed energy of a single test specimen is less in value than 70 % of the specified average absorbed energy, the test is considered to have failed.

## 6. Selection of test specimens

(1) One test sample is to be selected from each lot of every 25 steel forgings or fraction thereof, which belong to the same heat. In case of steel forgings having small diameter, the number of test samples may be reduced subject to approval of the Society. Where specially approved by

the Society, the test sample may be taken from the representative part of the steel forging at a proper time during manufacturing, or a separate sample forged to the forge ratio equivalent to that of the steel forgings. In this case, the test sample is to be heat treated simultaneously with the steel forgings.

- (2) For Grade 1 and Grade 2 chain bars, one tensile test specimen is to be taken from the test sample; for Grade 3 chain bars, one tensile test specimen and one set (3 pieces) of impact test specimens are to be taken from the test sample.
- (3) The tensile and impact test specimens are to be taken from the test sample in the direction of forging at a depth of 1/6 diameter from the surface or as close as possible to this position. (see Fig 2.1.5)

#### 7. Surface inspection

Surface inspection for all grades is to be carried out and it is to be confirmed that there are no harmful defects.

#### 8. Retest procedure

Where the tensile test or impact test on the selected first test specimens fails to meet the requirements, additional tests may be carried out according to the requirements given in 306. 9.

#### 9. Marking

Steel forgings which have satisfactorily complied with the required tests are to be marked with the identification mark in accordance with the requirement in 110.

### 604. Steel forgings for low temperature service

#### 1. Application

- (1) The requirements are to apply to the steel forgings for valves and pipe fittings in piping systems intended to be used at the design temperature lower than 0°C in liquefied gas carriers (hereinafter referred to as "steel forgings").
- (2) Steel forgings other than those specified in 604. are to comply with the requirements given in 101. 2.

2. Kinds The steel forgings are classified as given in Table 2.1.97.

#### 3. Heat treatment

The steel forgings are to be normalized, normalized and tempered, quenched and tempered or double normalized and tempered.

#### 4. Deoxidation practice and chemical composition

The deoxidation practice and chemical composition of each grade are to comply with the requirements given in Table 2.1.97.

Table 2.1.97 Grades and Chemical Composition

Grade	Deoxidation	Chemical composition (%)								
		C	Si	Mn	P	S	Ni	Cr	Cu	Al
RLFA	Fully killed fine grain	0.23 max.	0.15~0.35	1.10 max.	0.030 max.	0.030 max.	-	-	-	-
RLFB		0.20 max.	0.15~0.35	1.60 max.						
RLFC		0.12 max.	0.10~0.35	0.55~1.00			0.50~0.95	0.50~0.95	0.40~0.75	0.04~0.30
RLF3		0.20 max.	0.15~0.35	0.90 max.			3.25~3.75	-	-	-
RLF9		0.10 max.	0.10~0.35	0.90 max.			8.50~9.60			

#### 5. Mechanical properties

- (1) The mechanical properties of steel forgings are to comply with the requirements given in Table 2.1.98.



- (2) Where deemed necessary by the Society, other tests may be required in addition to the tests specified in (1).

**Table 2.1.98 Mechanical Properties**

Grade	Tensile test				Impact test <sup>(2)</sup>	
	Yield strength (N/mm <sup>2</sup> )	Tensile strength (N/mm <sup>2</sup> )	Elongation (%) ( $L = 5.65\sqrt{A}$ )	Reduction of area (%)	Test temp. (°C)	Average absorbed energy (J)
<i>RLFA</i>	205 min.	410 min.	23 min.	40 min.	- 40 <sup>(1)</sup>	27 min.
<i>RLFB</i>	275 min.	490 min.	20 min.		- 50 <sup>(1)</sup>	
<i>RLFC</i>	205 min.	410 min.	23 min.		- 60 <sup>(1)</sup>	
<i>RLF3</i>	275 min.	490 min.	23 min.	50 min.	- 95	34 min.
<i>RLF9</i>	520 min.	680 min.	19 min.	45 min.	- 196	41 min.

NOTES:

(1) Impact test temperature for steel forgings specified in **Pt 7, Ch 5** is to be 5°C below the design temperature or -20°C, Whichever is the lower.

(2) When the absorbed energy of two or more test specimens among a set of test specimens is less in value than the specified average absorbed energy or when the absorbed energy of a single test specimen is less in value than 70 % of the specified average absorbed energy, the test is considered to have failed.

#### 6. Selection of tests specimens

- (1) The number of test specimens is to be in accordance with the requirements specified in **601. 7**.
- (2) The test specimens for tensile and impact tests are to be cut with their longitudinal axes parallel to the direction of forging except where otherwise specially specified.
- (3) Where tests are made in accordance with the requirements in **601. 7** (5), (c) and (d), the Surveyor may require a hardness test for each forging.

#### 7. Retest procedures

- (1) Where the tensile tests fail to meet the requirements, additional tests may be carried out according to the requirements given in **109**.
- (2) Regarding the impact tests, additional tests are to be carried out according to the requirements given in **304. 9**.

#### 8. Marking

Marking for steel castings is to comply with the requirements given in **601. 13** (1) and in case the requirement in Note (1) of **Table 2.1.98** has been applied, "impact test temperature T" is to be suffixed to the marking (e.g. *RLFA - 25T*)

## Section 7 Copper and Copper Alloy

### 701. Copper and copper alloy pipes and tubes

#### 1. Application

- (1) The requirements are to apply to the copper and copper alloy pipes and tubes.
- (2) Copper and copper alloy pipes and tubes are to comply with the requirements in **KS D 5301** or equivalent thereto.
- (3) Copper and copper alloy pipes and tubes having characteristics differing from those specified in **701.** are to comply with the requirements in **101. 2.**

#### 2. Kinds

Copper and copper alloy pipes and tubes are classified as specified in **Table 2.1.99.**

**Table 2.1.99 Kinds and Grades**

Kinds		Grades
Copper pipes and tubes.	Phosphorus deoxidized copper seamless pipes and tubes	<i>C1201, C1220</i>
Copper alloy pipes and tubes	Brass seamless pipes and tubes	<i>C2600, C2700, C2800</i>
	Brass seamless pipes and tubes for condenser	<i>C4430, C6870, C6871, C6872</i>
	Cupro-nickel seamless pipes and tubes for condenser	<i>C7060, C7100, C7150</i>

#### 3. Mechanical properties

The mechanical properties of copper and copper alloy pipes and tubes are to comply with the requirements given in **Table 2.1.100.**

Table 2.1.100 Mechanical Properties

Kinds	Grade	Tensile test <sup>(1)</sup>	
		Tensile strength (N/mm <sup>2</sup> )	Elongation (%)
Phosphorus deoxidized copper seamless pipes and tubes.	C1201, C1220	206 min.	40 min.
Brass seamless pipes and tubes	C2600	275 min.	45 min.
	C2700	294 min.	40 min.
	C2800	314 min.	35 min.
Brass seamless pipes and tubes for condenser	C4430	314 min.	30 min.
	C6870, C6871, C6872	373 min. <sup>(2)</sup>	40 min.
		353 min. <sup>(3)</sup>	40 min.
Cupro-nickel seamless pipes and tubes for condenser	C7060	275 min.	30 min.
	C7100	314 min.	30 min.
	C7150	363 min.	30 min.

NOTES :

(1) These properties are a measure of the mechanical quality of the metal in annealed condition.  
(2) It is applicable to those having 5 mm and up to 50 mm in outside diameter.  
(3) It is applicable to those having over 50 mm up to 200 mm in outside diameter.

#### 4. Testing and inspection

Testing and inspection of pipes and tubes are to comply with the requirements specified in *KS D 5301*. Those subjected to the maximum working pressure not exceeding 1 MPa may not require the presence of the Society's Surveyor.

#### 5. Marking

Copper and copper alloy pipes and tubes which have satisfactorily complied with the required tests are to be marked with the identification mark in accordance with the requirements in **110**.

### 702. Copper alloy castings

#### 1. Application

(1) These requirements are to apply to the manufacture, inspection and repair procedures of copper alloy castings to be used for propellers and propeller blades (hereinafter referred to as "propeller castings"). Also, upon special consideration of the Society, these requirements may also be applied for the repair and inspection of propellers becoming damaged during service. (2021)

**[See Guidance]**

(2) Copper alloy castings to be used for important parts differing from those specified in **702**, are to comply with the requirements of *KS* or equivalent thereto. The tests and inspections need in general to be made in the presence of the Surveyor where special requirements are given in connection with the design.

(3) Copper alloy castings characteristics differing from those specified in **702**, are to comply with the requirements in **101. 2**.

**2. Kinds** Propeller castings are classified as specified in **Table 2.1.101**.

**Table 2.1.101 Kinds and Grades**

Kinds	Grade
High strength brass casting, Grade 1	CU1
High strength brass casting, Grade 2	CU2
Aluminium bronze casting, Grade 3	CU3
Aluminium bronze casting, Grade 4	CU4

### 3. Moulding and casting

- (1) The pouring must be carried out into dried moulds using degassed liquid metal.
- (2) The pouring is to be controlled as to avoid turbulences of flow. Special devices and/or procedures must prevent slag flowing into the mould.
- (3) Subsequent stress relieving heat treatment may be performed to reduce the residual stresses. For this purpose, the manufacturer shall submit a specification containing the details of the heat treatment to the Society for approval. The stress relieving temperatures and holding times should be in accordance with the Guidance relating to the Rules specified by the Society.

**【See Guidance】**

### 4. Chemical composition

- (1) The chemical composition of propeller castings is to comply with the requirements given in **Table 2.1.102**.

**Table 2.1.102 Chemical Composition**

Grade	Cu(%)	Al(%)	Mn(%)	Zn(%)	Fe(%)	Sn(%)	Ni(%)	Pb(%)
CU1	52~62	0.5~3.0	0.5~4.0	35~40	0.5~2.5	1.5 max	1.0 max.	0.5 max.
CU2	50~57	0.5~2.0	1.0~4.0	33~38	0.5~2.5	1.5 max	3.0~8.0	0.5 max.
CU3	77~82	7.0~11.0	0.5~4.0	1.0 max.	2.0~6.0	0.1 max.	3.0~6.0	0.03 max.
CU4	70~80	6.5~9.0	8.0~20.0	6.0 max.	2.0~5.0	1.0 max.	1.5~3.0	0.05 max.

- (2) The manufacturer is to maintain records of the chemical analyses of the production casts, which are to be made available to the Surveyor. (2021)
- (3) For CU1 and CU2, it is also to comply with the followings:
  - (a) The zinc equivalent as specified below is not to exceed 45 %

$$\text{Zinc equivalent} = 100 - \frac{100 \times Cu(\%)}{100 + A}$$

Where  $A : Sn + 5Al - 0.5Mn - 0.1Fe - 2.3Ni$  (%)

- (b) The micro structure is to be verified by determining the proportion of alpha phase. For this purpose, at least one specimen is to be taken from each heat. The proportion of alpha phase is to be determined as the average value of 5 counts. (2021)
- (c) Each tensile test specimen is to be examined metallographically, and the proportion of alpha-phase determined from an average of five counts is not to be less than 25 %.

### 5. Mechanical properties

- (1) The mechanical properties of copper propeller casting are to comply with the requirements given in **Table 2.1.103**.  
However, the requirements specified in this Table apply to specimens cut from separately cast samples, where specimens cut from propeller casting itself, the requirements are to be deemed appropriate by the Society. **【See Guidance】**

Table 2.1.103 Mechanical Properties

Grade	Yield strength <sup>(1)</sup> (N/mm <sup>2</sup> )	Tensile strength (N/mm <sup>2</sup> )	Elongation (%) ( $L=5d$ )
CU1	175 min.	440 min.	20 min.
CU2	175 min.	440 min.	20 min.
CU3	245 min.	590 min.	16 min.
CU4	275 min.	630 min.	18 min.

NOTE:

(1) Yield strength is measured as 0.2% proof stress and is applicable to the case which is specially required considering the design by the Society. **【See Guidance】**

(2) As for the materials of the propellers which used for the ship strengthened for navigation in ice, the elongation of the materials used is not to be less than 19% for R14A test specimen specified in **Pt 2, Ch 1** and absorbed energy for the Charpy V notch impact test is not to be less than 21 J at  $-10^{\circ}\text{C}$

## 6. Selection of Test Samples and Specimens

- Generally, the specimens shall be taken from separately cast sample pieces. The test samples shall be cast in moulds made of the same material as the mould for the propeller and they must be cooled down under the same conditions as the propeller. If propellers are subjected to a heat treatment, the test samples are to be heat treated together with them.
- The shapes and dimensions of the test samples are to comply with those given in **Fig 2.1.30**. The shape given by the dotted lines shown in the figure, however, may be acceptable.

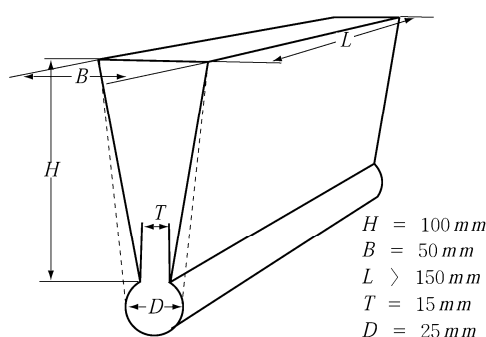


Fig 2.1.30 shapes and dimensions of the Test Samples

- One tensile test specimen is to be taken from each casting when integral test samples are provided and one tensile test specimen is to be taken from each ladle when separately-cast test samples are provided.
- For determining the proportion of alpha phase of alloy types CU 1 and CU 2, at least one specimen shall be taken from each heat. However tensile test specimen can be substitute for.
- When integral test samples are provided, the test samples shall be located on the blades in an area lying between 0,5 to 0,6 R (where R is the radius of the propeller). The test sample material must be removed from the casting by non thermal procedures.

## 7. Surface and dimension Inspection

- All finished castings are to be 100% visually inspected by the manufacturer. A general visual examination is to be carried out by the Surveyor. (2021)
- Castings are to be free from cracks, hot tears or other imperfections which, due to their nature, degree or extent, will interfere with the use of the castings. (2021)
- The dimensions are to be checked by the manufacturer and the report on the dimensional inspection is to be handed over to the Surveyor, who may require checks to be made in his presence. Where straightening of a bent blade is carried out, the procedure for the straightening

is to be in accordance with the Guidance relating to Rules specified by the Society.

**【See Guidance】**

- (4) The Surveyor may require areas to be etched (e.g. by iron chloride) for the purpose of investigating weld repairs.

## 8. Quality

All castings must have a workman like finish and must be free from defects liable to impair their use. Minor casting defects which may still be visible after machining such as small sand and slag inclusions, small cold shuts and scabs shall be trimmed off by the manufacturer in accordance with 10. (5).

## 9. Non-destructive inspection

- (1) The important parts of propeller castings are to be subjected to the liquid penetrant test in accordance with the Guidance relating to Rules specified by the Society. **【See Guidance】**
- (2) Qualification of personnel involved in NDT is in accordance with **Appendix Pt B 1.4, 1.5 and 1.9 of Guidance for Approval of Service Suppliers.** (2021)
- (3) The division of severity zones of propeller casting is to be in accordance with the Guidance relating to Rules specified by the Society. **【See Guidance】**
- (4) When required by the Society or when deemed necessary by the manufacturer, further non-destructive testing (e.g. radiographic and/or ultrasonic testing) are to be carried out. The acceptance criteria or applied quality levels are to be agreed between the manufacturer and the Society in accordance with a recognized standard. (2021)
- (5) All defects requiring welding repair on the propeller castings are to be documented preferably on drawings or special sketches showing their dimensions and locations. Furthermore, the inspection procedure is to be reported. The documentation is to be presented to the Surveyor prior to any repair weldings will be carried out.

## 10. Repair of defects

- (1) In the event of finding defects in the propeller castings, the defects may be removed by grinding, etc. After removing the defects, liquid penetrant tests are to be carried out to ensure that all defects have been completely removed.
- (2) Where the propeller castings from which defects were removed are used in that condition or after repaired by welding, the propeller castings are to be approved by the Surveyor.
- (3) After weld repairs, the portions repaired by welding are to be subjected to the stress-relieving treatments.
- (4) It is to be confirmed that the portions repaired by welding are free from harmful defects by the non-destructive inspections such as liquid penetrant test, etc.
- (5) The repair welding procedures are to have prior approval of the Surveyor in accordance with the Guidance relating to the Rules specified by the Society. **【See Guidance】**
- (6) The foundry is to maintain records of inspections, welding, and any subsequent heat treatment, traceable to each casting. Before welding is started, full details of the extent and location of the repair, the proposed welding procedure, heat treatment and subsequent inspection procedures are to be submitted to the Society for approval. (2021)

## 11. Retest procedure

Where the results of tensile tests fail to meet the requirements, additional test may be carried out in accordance with the requirements of 109.

## 12. Identification and Marking (2021)

- (1) The manufacturer is to adopt a system for the identification of all castings, which enable the material to be traced to its original cast. The Surveyor is to be given full facilities for so tracing the castings when required.
- (2) Each finished casting propeller shall be marked by the manufacturer at least with the following particulars:
  - (a) Grade of cast material or corresponding abbreviated designation
  - (b) Manufacturer's mark
  - (c) Heat number, casting number or another mark enabling the manufacturing process to be traced back
  - (d) Date of final inspection
  - (e) Number of the Society's test certificate

- (f) Ice class symbol, where applicable
- (g) Skew angle for high skew propellers.

### 13. Test certificates

For each propeller the manufacturer is to supply to the Surveyor a certificate containing the following details:

- (1) Purchaser and order number
- (2) Shipbuilding project number, if known
- (3) Description of the casting with drawing number
- (4) Diameter, number of blades, pitch, direction of turning
- (5) Grade of alloy and chemical composition of each heat
- (6) Heat or casting number
- (7) Final weight
- (8) Results of non-destructive tests and details of test procedure where applicable
- (9) Portion of alpha-structure for CU 1 and CU 2 alloys
- (10) Results of the mechanical tests
- (11) Casting identification No.
- (12) Skew angle for high skew propellers

## Section 8 Aluminium Alloys

### 801. Aluminium alloys

#### 1. Application

- (1) These requirements are to apply to the aluminium alloy plates and extruded shapes (hereinafter referred to as "aluminium alloys") intended to be used in the construction of hulls, super-structures, other marine structures and tanks of liquefied gas carriers.
- (2) Where aluminium alloys exceeding the maximum value of plate thickness or size specified in **Table 2.1.105** and **Table 2.1.106** are manufactured, a new approval test is required by the Society. **[See Guidance]**
- (3) Aluminium alloys having characteristics differing from those specified in **801.** are to comply with the requirements in **101. 2.**

#### 2. Kinds

The aluminium alloys are classified as specified in **Table 2.1.104.**

**Table 2.1.104 Kinds**

Product		Grades	Temper condition
Rolled	5000 series	5083P, 5086P, 5383P, 5059P, 5754P, 5456P	O, H111, H112, H116, H321
Extruded Shapes	5000 series	5083S, 5383S, 5059S, 5086S	O, H111, H112
	6000 series	6005AS <sup>(1)</sup> , 6061S <sup>(1)</sup> , 6082S	T5, T6

NOTE :

(1) These alloy should not be used in direct contact with sea water unless protected by anodes and/or paint system.

#### 3. Chemical composition

- (1) The chemical composition of aluminium alloys is to comply with the requirements given in **Table 2.1.105.**

**Table 2.1.105 Chemical Composition**

Grades	Chemical composition (%)										
	Si	Fe	Cu	Mn	Mg	Cr	Zn	Ti	Others <sup>(1)</sup>		Al
									Each	Total	
5083P 5083S	0.40max.	0.40max.	0.10max.	0.40~1.0	4.0~4.9	0.05~0.25	0.25max.	0.15max.	0.05max.	0.15max.	Remainder
5383P 5383S	0.25max.	0.25max.	0.20max.	0.70~1.0	4.0~5.2	0.25max.	0.40max.	0.15max.	0.05max. <sup>(4)</sup>	0.15max. <sup>(4)</sup>	
5059P 5059S	0.45max.	0.50max.	0.25max.	0.60~1.2	5.0~6.0	0.25max.	0.4~0.90	0.20max.	0.05max. <sup>(5)</sup>	0.15max. <sup>(5)</sup>	
5086P 5086S	0.40max.	0.50max.	0.10max.	0.20~0.7	3.5~4.5	0.05~0.25	0.25max.	0.15max.	0.05max.	0.15max.	
5754P <sup>(2)</sup>	0.40max.	0.40max.	0.10max.	0.50max.	2.6~3.6	0.30max.	0.20max.	0.15max.	0.05max.	0.15max.	
5456P	0.25max.	0.40max.	0.10max.	0.50~1.0	4.7~5.5	0.05~0.2	0.25max.	0.20max.	0.05max.	0.15max.	
6005AS <sup>(3)</sup>	0.5~0.9	0.35max.	0.30max.	0.50max.	0.40~0.7	0.30max.	0.20max.	0.10max.	0.05max.	0.15max.	
6061S	0.4~0.8	0.7max.	0.15~0.40	0.15max.	0.8~1.2	0.04~0.35	0.25max.	0.15max.	0.05max.	0.15max.	
6082S	0.7~1.3	0.50max.	0.10max.	0.40~1.0	0.6~1.2	0.25max.	0.20max.	0.10max.	0.05max.	0.15max.	

NOTES :

- (1) Includes Ni, Ga, V and listed elements for which no specific limit is shown. When the existence of the other elements is presumed in the course of routine analysis, further analysis thereof is to be conducted.
- (2)  $0.10 \leq Mn + Cr \leq 0.60$
- (3)  $0.12 \leq Mn + Cr \leq 0.50$
- (4) Zr: maximum 0.20. The total for other elements does not include Zirconium.
- (5) Zr: 0.05~0.25. The total for other elements does not include Zirconium.



- (2) When the aluminium alloys are not cast in the same works in which they are manufactured into semi finished products, the Society Surveyor shall be given a certificate issued by the works in question which indicates the reference numbers and chemical composition of the heats.

**4. Heat treatment**

The heat treatment(hereinafter referred to as "temper condition") of the aluminium alloys is to comply with the requirements given in **Table 2.1.106** and **Table 2.1.107**.

**5. Mechanical properties**

- (1) The mechanical properties in tension tests are to comply with the requirements given in **Tables 2.1.106** and **2.1.107**.

Table 2.1.106 Mechanical Properties for Rolled Products<sup>(1)</sup> (2021) (2022)

Grades	Temper condition <sup>(2)</sup>	Thickness, <i>t</i> (mm)	Tensile test			
			Yield strength (N/mm <sup>2</sup> )	Tensile strength (N/mm <sup>2</sup> )	Elongation(%) <sup>(4)</sup>	
					( <i>L</i> = 50)	( <i>L</i> = 5 <i>d</i> )
5083P	<i>O</i>	3 ≤ <i>t</i> ≤ 50	125 min.	275~350	16 min.	14 min.
	<i>H111</i>	3 ≤ <i>t</i> ≤ 50	125 min.	275~350	16 min.	14 min.
	<i>H112</i>	3 ≤ <i>t</i> ≤ 50	125 min.	275 min.	12 min.	10 min.
	<i>H116</i>	3 ≤ <i>t</i> ≤ 50	215 min.	305 min.	10 min.	10 min.
	<i>H321</i>	3 ≤ <i>t</i> ≤ 50	215~295	305~385	12 min.	10 min.
5383P	<i>O</i>	3 ≤ <i>t</i> ≤ 50	145 min.	290 min.	-	17 min.
	<i>H111</i>	3 ≤ <i>t</i> ≤ 50	145 min.	290 min.	-	17 min.
	<i>H116</i> or <i>H321</i>	3 ≤ <i>t</i> ≤ 50	220 min.	305 min.	10 min.	10 min.
5059P	<i>O</i>	3 ≤ <i>t</i> ≤ 50	160 min.	330 min.	-	24 min.
	<i>H111</i>	3 ≤ <i>t</i> ≤ 50	160 min.	330 min.	-	24 min.
	<i>H116</i> or <i>H321</i>	3 ≤ <i>t</i> ≤ 20	270 min.	370 min.	10 min.	10 min.
		20 < <i>t</i> ≤ 50	260 min.	360 min.	10 min.	10 min.
5086P	<i>O</i>	3 ≤ <i>t</i> ≤ 50	95 min.	240~305	16 min.	14 min.
	<i>H111</i>	3 ≤ <i>t</i> ≤ 50	95 min.	240~305	16 min.	14 min.
	<i>H112</i>	3 ≤ <i>t</i> ≤ 12.5	125 min.	250 min.	8 min.	-
		12.5 < <i>t</i> ≤ 50	105 min.	240 min.	-	9 min.
	<i>H116</i>	3 ≤ <i>t</i> ≤ 50	195 min.	275 min.	10 min. <sup>(3)</sup>	9 min.
5754P	<i>O</i>	3 ≤ <i>t</i> ≤ 50	80 min.	190~240	18 min.	17 min.
	<i>H111</i>	3 ≤ <i>t</i> ≤ 50	80 min.	190~240	18 min.	17 min.
5456P	<i>O</i>	3 ≤ <i>t</i> ≤ 6.3	130~205	290~365	16 min.	-
		6.3 < <i>t</i> ≤ 50	125~205	285~360	16 min.	14 min.
	<i>H116</i>	3 ≤ <i>t</i> ≤ 30	230 min.	315 min.	10 min.	10 min.
		30 < <i>t</i> ≤ 40	215 min.	305 min.	-	10 min.
		40 < <i>t</i> ≤ 50	200 min.	285 min.	-	10 min.
	<i>H321</i>	3 ≤ <i>t</i> ≤ 12.5	230~315	315~405	12 min.	-
		12.5 < <i>t</i> ≤ 40	215~305	305~385	-	10 min.
		40 < <i>t</i> ≤ 50	200~295	285~370	-	10 min.

NOTES :

(1) Aluminium alloy may be subject to any other standards in lieu of the requirements given in this Table where they are approved by the Society.

(2) Symbols used in temper condition are as follows **【See Guidance】**:

*O* : Annealing

*H111*, *H112*, *H116* : Work hardened

*H321* : Stabilizing treatment after work hardened

(3) 8% for thicknesses up to and including 6.3 mm.

(4) Elongation in *L* = 50 apply for thicknesses up to and including 12.5 mm and in *L* = 5*d* for thicknesses over 12.5 mm

Table 2.1.107 Mechanical Properties for Extruded Shapes<sup>(1)</sup> (2022)

Grades	Temper condition <sup>(2)</sup>	Thickness, <i>t</i> (mm)	Tensile test			
			Yield strength (N/mm <sup>2</sup> )	Tensile strength (N/mm <sup>2</sup> )	Elongation(%) <sup>(3)(4)</sup>	
					( <i>L</i> = 50)	( <i>L</i> = 5 <i>d</i> )
5083S	O	3 ≤ <i>t</i> ≤ 50	110 min.	270~350	14 min.	12 min.
	H111	3 ≤ <i>t</i> ≤ 50	165 min.	275 min.	12 min.	10 min.
	H112	3 ≤ <i>t</i> ≤ 50	110 min.	270 min.	12 min.	10 min.
5383S	O/H111	3 ≤ <i>t</i> ≤ 50	145 min.	290 min.	17 min.	17 min.
	H112	3 ≤ <i>t</i> ≤ 50	190 min.	310 min.	-	13 min.
5059S	H112	3 ≤ <i>t</i> ≤ 50	200 min.	330 min.	-	10 min.
5086S	O	3 ≤ <i>t</i> ≤ 50	95 min.	240~315	14 min.	12 min.
	H111	3 ≤ <i>t</i> ≤ 50	145 min.	250 min.	12 min.	10 min.
	H112	3 ≤ <i>t</i> ≤ 50	95 min.	240 min.	12 min.	10 min.
6005AS	T5	3 ≤ <i>t</i> ≤ 50	215 min.	260 min.	9 min.	8 min.
	T6	3 ≤ <i>t</i> ≤ 10	215 min.	260 min.	8 min.	6 min.
		10 < <i>t</i> ≤ 50	200 min.	250 min.	8 min.	6 min.
6061S	T6	3 ≤ <i>t</i> ≤ 50	240 min.	260 min.	10 min.	8 min.
6082S	T5	3 ≤ <i>t</i> ≤ 50	230 min.	270 min.	8 min.	6 min.
	T6	3 ≤ <i>t</i> ≤ 5	250 min.	290 min.	6 min.	-
		5 < <i>t</i> ≤ 50	260 min.	310 min.	10 min.	8 min.

NOTES :

(1) Aluminium alloy may be subject to any other standards in lieu of the requirements given in this Table where they are approved by the Society.

(2) Symbols used in temper condition are as follows **【See Guidance】**:  
*O* : Annealing  
*H111* : Work hardened  
*H112* : Work hardened  
*T5* : Artificial age hardening treatment after elevated temperature working and succeeding cooling  
*T6* : Artificial age hardening treatment after solution treatment

(3) The values are applicable for longitudinal and transverse tensile test specimens as well.

(4) Elongation in *L*=50 apply for thicknesses up to and including 12.5 mm and in *L*=5*d* for thicknesses over 12.5 mm

(2) Where deemed necessary by the Society, other tests may be required in addition to the specified tests. **【See Guidance】**

### 6. Selection of test samples

(1) For test samples for rolled products, if the weight of one lot exceeds 2 tonnes, one extra test specimen is to be taken from every 2 tonnes of the product or fraction thereof, in each lot except where specially approved by the Society.

One lot is made up of rolled products of the same alloy and from the same cast, of the same thickness, manufactured by the same process and having been submitted simultaneously to the same temper condition. For single plate or coil weighting more than 2 tonnes each, one lot is made up of a single plate or coil.

(2) For test samples for extruded shapes with a nominal weight of less than 1 kg/m, except where specially approved by the Society, one test specimen is to be taken from each 1 tonne, or fraction thereof, in each lot. For nominal weights between 1 and 5 kg/m, one test specimen is to be taken from each 2 tonnes or fraction hereof, in each lot. If the nominal weight exceeds 5 kg/m, one test specimen is to be taken for each 3 tonnes of the product or fraction thereof, in each lot.

One lot is made up of rolled products of the same alloy and from the same cast, of the same dimension, manufactured by the same process and having been submitted simultaneously to the same temper condition.

- (3) Test samples are to be taken out of the place at one third of the width from a longitudinal edge of rolled products, or in the range 1/3 to 1/2 of the distance from the edge to the centre of the thickest part of extruded products.
- (4) After removal of test samples, each test specimen is to be marked in order that its original identity, location and orientation is maintained.

#### 7. Selection of test specimens

Tensile test specimens are to be taken according to (1) to (4) below.

- (1) One test specimen is to be taken out of each test sample.
- (2) For rolled products, the longitudinal axis of the test specimen is to be taken transversely to the rolling direction. If the width is insufficient to obtain transverse test specimen or in the case of strain hardening alloys, however, the longitudinal direction may be taken parallel to the rolling direction.
- (3) For extruded shapes, the longitudinal axis of the test specimen is to be taken parallel to the extruding direction.
- (4) For thickness of test sample up to and including 40 mm, the longitudinal axis of the test specimen is to be located at a distance from the surface equal to half of the thickness. For thickness of test sample over 40 mm, the longitudinal axis of the test specimen is to be located at a distance from one of the surfaces equal to one quarter of the thickness.

#### 8. Drift expansion tests

The manufacturer has to demonstrate by macrosection tests or drift expansion tests of closed profiles performed on each batch of closed profiles that there is no lack of fusion at the press welds.

- (1) Every fifth profile shall be sampled after final heat treatment. Batches of five profiles or less shall be sampled one profile. Profiles with lengths exceeding 6 m shall be sampled every profile in the start of the production. The number of tests may be reduced to every fifth profile if the results from the first 3–5 profiles are found acceptable.
- (2) Each profile sampled will have two samples cut from the front and back end of the production profile.
- (3) The test specimens are to be cut with the ends perpendicular to the axis of the profile. The edges of the end may be rounded by filing.
- (4) The lengths of the drift expanding test specimens are to be equal to 1.5 times the external diameter(D) of the test specimen in accordance with *(KS B) ISO 8493:1998*. The test piece may be shorter provided that after testing the remaining cylindrical portion is not less than 0.5D. (2023)
- (5) Testing is to be carried out at ambient temperature and is to consist of expanding the end of the profile by means of a hardened conical steel mandrel having an included angle of at least 60°.
- (6) The sample is considered to be unacceptable if the sample fails with a clean split along the weld line which confirms lack of fusion.

#### 9. Corrosion testing

##### (1) Testing procedures

- (a) Rolled 5xxx-alloys of type 5083, 5383, 5059, 5086 and 5456 in the H116 and H321 tempers intended for use in marine hull construction or in marine applications where frequent direct contact with seawater is expected are to be corrosion tested with respect to exfoliation and intergranular corrosion resistance. The manufacturers shall establish the relationship between microstructure and resistance to corrosion when the above alloys are approved.
- (b) A reference photomicrograph taken at 500x, under the conditions specified in *ASTM B928:2015*, Section 9.4.1, shall be established for each of the alloy–tempers and thickness ranges relevant. (2023)
- (c) The reference photographs shall be taken from samples which have exhibited no evidence of exfoliation corrosion and a pitting rating of PB or better, when subjected to the test described in *ASTM G66:2018 (ASSET)*. (2023)
- (d) The samples shall also have exhibited resistance to intergranular corrosion at a mass loss no greater than 15mg/cm<sup>2</sup>, when subjected to the test described in *ASTM G67:2018 (NAMLT)*. (2023)
- (e) Upon satisfactory establishment of the relationship between microstructure and resistance to corrosion, the master photomicrographs and the results of the corrosion tests are to be approved by the Society. Production practices shall not be changed after approval of the refer-

ence micrographs.

(f) Other test methods may also be accepted at the discretion of the Society.

(2) **Acceptance criteria**

(a) For batch acceptance of 5xxx-alloys in the H116 and H321 tempers, metallographic examination of one sample selected from mid width at one end of a coil or random sheet or plate is to be carried out in accordance with *ASTM B928:2015* or equivalent standards agreed by the Society. The microstructure of the sample is to be compared to the reference photomicrograph of acceptable material in the presence of the Surveyor. (2023) **[See Guidance]**

(b) If the microstructure shows evidence of continuous grain boundary network of aluminium-magnesium precipitate in excess of the reference photomicrographs of acceptable material, the batch is either to be rejected or tested for exfoliation-corrosion resistance and intergranular corrosion resistance subject to the agreement of the Surveyor.

(c) Corrosion tests with respect to exfoliation and intergranular corrosion resistance are to be in accordance with *ASTM G66:2018* and *G67:2018* or equivalent standards agreed by the Society. (2023) **[See Guidance]**

(i) The samples have exhibited no evidence of exfoliation corrosion and a pitting rating of PB or better when subjected to the test described in *ASTM G66:2018*. (2023)

(ii) The samples shall also have exhibited resistance to intergranular corrosion at a mass loss no greater than 15 mg/cm<sup>2</sup>, when subjected to the test described in *ASTM G67:2018*. (2023)

If the results from testing satisfy the acceptance criteria, the batch is accepted, else it is to be rejected.

(d) As an alternative to metallographic examination, each batch may be tested for exfoliation-corrosion resistance and intergranular corrosion resistance, in accordance with *ASTM G66:2018* and *G67:2018* under the conditions specified in *ASTM B928:2015*, or equivalent standards. If this alternative is used, then the results of the test must satisfy the acceptance criteria stated in (c) above. (2023)

**10. Surface inspection and dimensional tolerance**

(1) Surface inspection and verification of dimensions are left to the responsibility of the manufacturer.

(2) The under-thickness tolerances of rolled products are to comply with the requirements given in **2.1.108**. The under-thickness tolerances of extruded shapes and other dimensional tolerances are to be as deemed appropriate by the Society. **[See Guidance]**

**Table 2.1.108 Under-thickness Tolerance for Rolled Products**

Nominal thickness, $t$ (mm)	Nominal width $W$ (mm)		
	$W \leq 1500$	$1500 < W \leq 2000$	$2000 < W \leq 3500$
	Under-thickness tolerance (mm)		
$3 \leq t < 4$	0.10	0.15	0.15
$4 \leq t < 8$	0.20	0.20	0.25
$8 \leq t < 12$	0.25	0.25	0.25
$12 \leq t < 20$	0.35	0.40	0.50
$20 \leq t < 50$	0.45	0.50	0.65

(3) Dimensional tolerance except those specified in (2) above is left to the discretion of the Society. **[See Guidance]**

**11. Quality**

(1) Aluminium alloys are to be of uniform quality and free from internal and surface harmful defects prejudicial to the use of the concerned material for the intended application.

(2) Slight surface imperfections may be removed by smooth grinding or machining as long as the thickness of the materials remains within the tolerances given in **Table 2.1.108**.

## 12. Retest procedures

- (1) When the tensile test from the first piece selected fails to meet the requirements given in **Table 2.1.106** and **2.1.107**, two further tensile tests may be made from the same piece. If both of these additional tests meet all of the requirements, the piece and the remaining pieces from the same lot may be accepted.
- (2) If one or both of the additional tests referred to above (1) are unsatisfactory, the piece is to be rejected. However, the remaining materials from the same lot may be accepted provided that two of the remaining pieces in the lot selected in the same way, are tested with satisfactory results.

## 13. Marking

- (1) Aluminium alloys which have satisfied with the required tests are to be marked with the identification mark in accordance with the requirements in **110. 1**. In this case, the mark of temper conditions is to be put subsequent to the mark of material grade. (ex : 5083 PH321)
- (2) For aluminium alloy, which have satisfied with the corrosion resistance tests specified in **801. 9**, the mark of [M] is to be put subsequent to the mark of the temper condition (ex : 5083 PH321 M)

## 14. Test certificates (2017)

For each tested batch, the manufacturer is to supply to Surveyor a test certificate, containing the following details:

- (1) Purchaser and order number
- (2) Construction project number, when known
- (3) Number, dimensions and weight of the product
- (4) Designation of the aluminium alloy (grade) and of its temper condition (heat treatment)
- (5) Chemical composition
- (6) Manufacturing batch number or identifying mark
- (7) Mechanical Test results
- (8) Corrosion Test results (if any)

## 802. Aluminium/steel transition joints (2023)

### 1. Application

- (1) The requirements in **802.** are to apply to bonded composite aluminium/steel transition joints used for connecting aluminium structures to steel structures in the ships.
- (2) Aluminium/steel transition joints having characteristics differing from those specified in **802.** are to comply with the requirements in **101. 2**.

### 2. Process of manufacture

- (1) The main method of manufacturing transition joints is an explosion bonding.
- (2) Transition joints are to be manufactured by an approved manufacturer in accordance with an approved procedure that includes the maximum allowable welding temperature.
- (3) Transition joints can use two bonding materials by using an intermediate bonding material that connects the base metal and bonding material.
- (4) Application of any other process of manufacture than those specified in (1) is left to the discretion of the Society. **[See Guidance]**

### 3. Structural metals

- (1) Base and bonding materials for steel plates are to be rolled steels for hull specified in **301.** and aluminium alloys specified in **801.**, respectively.
- (2) Materials other than those specified in **Pt 2** of the Rules are permitted for the intermediate bonding material connecting the base metal and the bonding material, and it is in accordance with the approved manufacturing process.
- (3) The material grade marks are to be signified by a combination of base metal and bonding material. (ex. A + 5083P)

### 4. Heat treatment

The transition joints are to comply with the requirements for heat treatment of the base metal.

## 5. Mechanical properties

### (1) Tensile test

(A) Two test specimens are taken from one test sample and tensile test is to comply with the requirements given in **Table 2.1.109**.

(B) The test specimens are to be determined according to **Fig 2.1.31**. The size and dimensions of test specimens are in accordance with national/international standards recognized by the Society.

### (2) Shear test

(A) Two test specimens are taken from one test sample and tensile test is to comply with the requirements given in **Table 2.1.109**.

(B) The size and dimensions of the test specimens, are to be determined according to **309. 7**.

### (3) Bend test

Two test specimens are taken from one test sample and tensile test is to comply with the requirements given in **Table 2.1.109**.

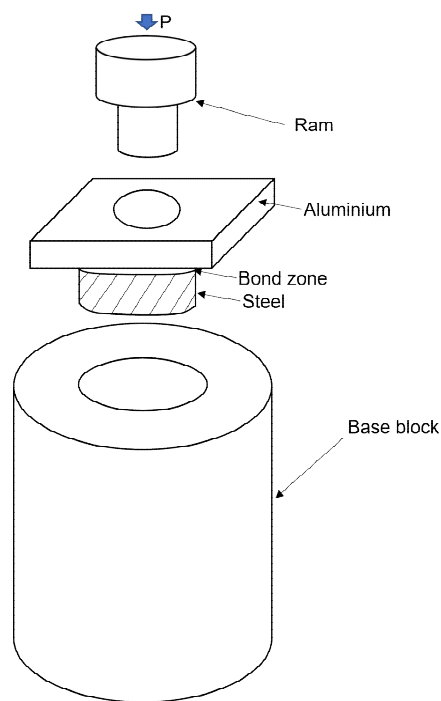


Fig 2.1.31 Ram tensile test (2023)

Table 2.1.109 Mechanical properties

Condition of specimens	Tensile test		Shear test		Bend test <sup>(1)</sup>	
	Test method	Tensile strength (N/mm <sup>2</sup> )	Test method	Shear strength (N/mm <sup>2</sup> )	Test method	Acceptance criteria
As manufactured condition	Ram tensile test at room temperature according to <b>Figure 2.1.31</b> <sup>(2)</sup>	min. 75	In accordance with <b>Pt 2, Ch 1, 309. 5</b> of the Rules.	min. 60	Two side bend test specimens (Minimum bend degree with 90° and diameter of former with 6T)	No separation of the bonding material or no cracks.
For considering welding heat (After maintaining 15 minutes with 300 °C)					-	-
(Notes)						
(1) In case of special request at order, it is carried out.						
(2) The test procedure is in accordance with national/international standards recognized by the Society.						

## 6. Selection of test samples

- (1) One test sample is to be taken from each steel plate, being from the same manufacturing process, which belong to the plate as rolled from a slab or ingot of a certain base metal.
- (2) The requirements specified in **301. 6** (4) are to be applied to the selection of the test samples.

## 7. Surface inspection and verification of dimensions

The minus tolerance for the nominal thickness of plates is left to the discretion of the Society.  
**【See Guidance】**

## 8. Quality and repair of defects **【See Guidance】**

- (1) Each steel plate is to be subjected to ultrasonic testing 100%. Any requirement for the test procedure is left to the discretion of the Society.
- (2) Unbonded areas are not acceptable and any unbonded area plus 25 mm of surrounding sound material is to be discarded.

## 9. Marking

- (1) The test certificates are to comply with the requirements given in **107**, and are to contain the particulars as to the process of manufacture of steel plates and the thickness of the bonding material.
- (2) Steel plates which have satisfactorily complied with the required tests are to be suffixed with the following marks relating to the process of manufacture of the steel plates, in addition to the marks showing the kinds of the base and bonding materials. (e.g. *A + 5083P - B*)

Rolling	:	<i>[-R]</i>
Cast rolling	:	<i>[-ER]</i>
Explosive bonding	:	<i>[-B]</i>
Explosive rolling	:	<i>[-BR]</i>
Overlay rolling	:	<i>[-WR]</i> ↓



---

## CHAPTER 2 WELDING

### Section 1 General

#### 101. Application

1. Welding to be used in hull construction and important equipment is to be in accordance with the requirements in this Chapter unless otherwise specified.
2. The welding in boiler, pressure vessel, main engine, auxiliary engine and pipe arrangement is to be in accordance with the requirements in **Pt 5, Chs 2, 5 and 6** except where prescribed in this Chapter.

#### 102. Matters to be approved

1. The welding is to be carried out in accordance with the procedures previously approved, with the electrodes, the wire and flux (hereinafter referred to as "**welding consumables**") or equivalent materials and by the welders qualified by the Society.
2. Where deemed appropriate by the Society, National Standards, internationally recognized Codes or Standards considered as equivalent for those may be applied instead of requirements of this Chapter. **[See Guidance]**

#### 103. Special weldings

Where special welding and material not complied with the requirements in this Chapter is used, the welding procedures and the welding consumables are to be specially approved by the Society.

#### 104. Terms and definitions

1. The term manual welding is used to describe processes in which the weld is made manually by a welder using a manually fed electrode such as shield metal arc welding, etc.
2. The term semi-automatic is used to describe processes in which the weld is made manually by a welder holding a gun through which the electrode wire is continuously fed such as metal arc welding or flux-cored arc welding, etc.
3. The term automatic welding is used to describe processes in which the weld is made automatically by a welder using a continuously fed electrode wire such as submerged arc welding or electro-slag welding, etc.

## Section 2 Test Specimens and Testing Procedures

### 201. General

1. Test specimens and mechanical testing procedures specified in this Chapter for welding procedure qualification tests, welders and qualification tests, approval test and periodical inspection of welding consumables are to comply with the requirements in this Section.
2. Where specimens and mechanical testing procedures differing from those prescribed in this Section are used, they are to be approved by the Society.

### 202. Selection of test specimens

1. Test specimens are to be selected according to respective requirements in each Section.
2. Except where otherwise specified or agreed with the Surveyor, test specimens are not to be detached from the test assembly until having been stamped by the Surveyor.
3. If test specimens are cut from test assemblies by flame cutting or shearing, a reasonable margin is required to enable sufficient material to be removed from the cut edges during final machining.
4. The preparation of test specimens is to be done in such a manner that test specimens are not subjected to any significant cold straining or heating.
5. If any test specimen shows defective machining or defects having no relation to the substantial nature, it may be discarded and substituted by another test specimen.

### 203. Size and dimensions of test specimens

#### 1. Tensile test specimens

- (1) Tensile test specimens are to be of size and dimensions given in **Table 2.2.1**, and the both ends of the test specimen may be machined to such a shape as to fit the holder of the testing machine.
- (2) The upper and lower surfaces of weld are to be filed, ground or machined flush with the surface of plate.
- (3) When the capacity of the available testing machine does not permit testing the full thickness specimen, two or more thinner than full thickness specimens may be prepared by cutting the full thickness specimens into section, each of which is to meet the requirements.

#### 2. Bend test specimens

- (1) Bend test specimens are to be of size and dimensions given in **Table 2.2.2** according to the kind of test assemblies.
- (2) Where the thickness of test assemblies is greater than the thickness of the bend test specimen prescribed in **Table 2.2.2**, the face bend or root bend specimen may be machined on its compression side.
- (3) Reinforcements and back straps are to be machined flush with base metal.

#### 3. Impact test specimens

Impact test specimens are to be charpy V-notch impact test specimens specified in **Ch 1, 202. 3** and to be of size and dimensions given in **Fig 2.1.3, Tables 2.1.3 and 2.1.4**.

#### 4. Confirmation for test specimens

The size and dimensions of test specimens are to be carefully inspected and verified by suitable means before testing.

Table 2.2.1 Size and Dimensions of Tensile Test Specimens (Unit : mm)

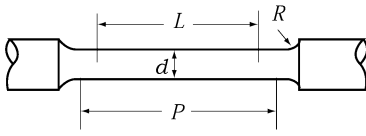
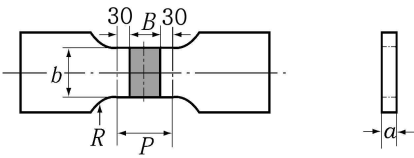
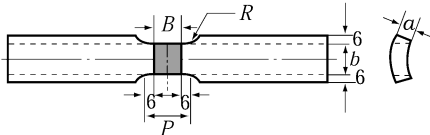
Type	Size of specimen	Dimensions	Intended for
R14A		$d = 10$ $L = 50$ $P = 55$ $R \geq 10$  Alternatively. $L = 5d$ $P \cong L + 0.5d$ $R = 12$	Deposited metal tensile test  Longitudinal tensile test
R10		$t = 12$ $d = 6.0$ $L = 24$ $P = 32$ $R \cong 6$	Deposited metal tensile test (Welding consumables for stainless steel)
		$t = 19 \sim 25$ $d = 12.5$ $L = 50$ $P = 60$ $R \cong 15$	
R2A		$a = t$ $b = 12 (t \leq 2)$ $b = 25 (t > 2)$ $P = B + 60$ $R > 25$	Butt weld tensile test for plate
R2B		$a = t$ $b = 38 (t \leq 25)$ $b = 25 (t > 25)$ $P = B + 12$ $R \geq 50$	Butt weld tensile test for pipe
NOTE: The notations used are defined as follows: $d$ : Diameter $a$ : Thickness $b$ : Width		$L$ : Gauge length $P$ : Parallel test length $B$ : Width of weld $R$ : Transition radius $t$ : Thickness of material	

Table 2.2.2 Size and Dimensions of Bend Test Specimens (Unit : mm) (2023)

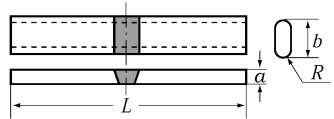
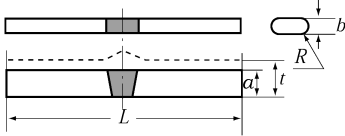
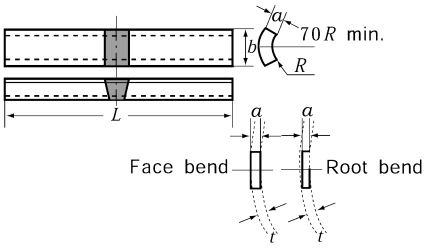
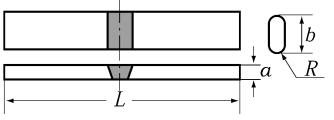
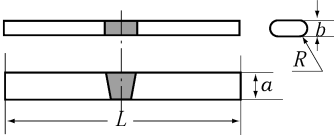
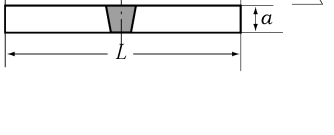
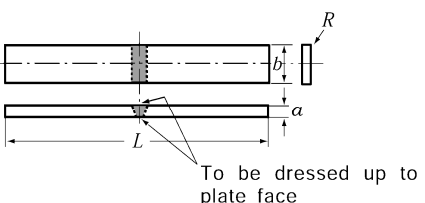
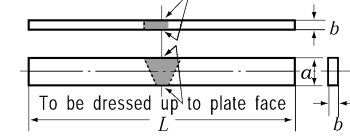
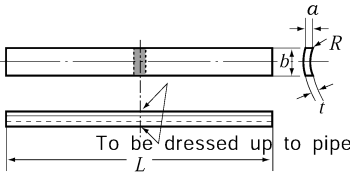
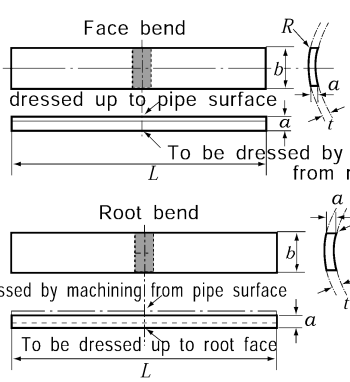
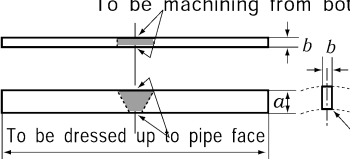
Used for	Type	Size of specimen	Dimensions <sup>(1)</sup>	Intended for	
Welding procedure qualification tests	Face and root bend specimen	RB 1		$t < 12$ $a = t$ $b = 30$ $L \geq 200$ $R = 1 \sim 2$	Butt weld bend test for plate Longitudinal bend test for plate <sup>(2)</sup>
	Side bend specimen	RB 2		$12 \leq t$ $a = t$ <sup>(3)</sup> $b = 10$ $L \geq 200$ $R = 1 \sim 2$	Butt weld bend test for plate or pipe
	Face and root bend specimen	RB 3		<sup>①</sup> $0 < t < 9$ $a = t$ $b = t + D/10$ $L \cong 250$ $R \leq a/6$ <sup>②</sup> $9 \leq t \leq 12$ $a = 9$ $b = 40$ $L \cong 250$ $R \leq 1.5$	Butt weld bend test for pipe
Approval test and periodical inspection for welding consumables	Face and root bend specimen	RB 4		$a = t$ $b = 30$ $L \geq 200$ $R \leq 1.5$ Where the thickness of test assemblies exceeds 25 mm, the thickness of test specimen may be reduced to 25 mm with its surface machined on one side only (compression side)	Butt weld bend test
	Side bend specimen	RB 5		$a = t$ $b = 10$ $L \geq 200$ $R \leq 1.5$	Butt weld bend test (welding materials for electro-slag and electro-gas)
		RB 6		$a = t$ $b = 9$ $L \geq 200$ $R \leq 1.5$	Butt weld bend test (MIG double side, one layer each, butt welding for aluminium alloy)
Welder's	Face and root bend specimen	RB 7		$t < 12$ $a = t$ $b = 30$ $L \cong 150$ $R \leq 1.5$	Butt weld bend test for pipe

Table 2.2.2 Size and Dimensions of Bend Test Specimens (Continued) (Unit : mm) (2023)

Used for	Type	Size of specimen	Dimensions <sup>(1)</sup>	Intended for
Welder's qualification test	Side bend specimen	<p>To be dressed by machining from both side</p> 	$12 \leq t$ $a = t^{(3)}$ $b = 9$ $L \cong 150$ $R \leq 1.5$	Butt weld bend test for plate
	Face and root bend specimen	<p>Face bend</p> 	$t \leq 9.5$ $a = t$ $L \cong 150$ $R \leq 1.5$ $b = 40$ $(D)100$ or $25(D \leq 100)$	Butt weld bend test for pipe
		<p>Root bend</p> 	$t > 9.5$ $a = 10$ $L \cong 150$ $R \leq 1.5$ $b = 40$ $(D)100$ or $25(D \leq 100)$	
Side bend specimen	<p>To be machining from both side</p> 	$12 \leq t$ $a = t^{(3)}$ $b = 9$ $L \cong 150$ $R \leq 1.5$		

NOTES:

(1) The following designations are used.

- $a$  : Thickness
- $b$  : Width
- $R$  : Edge radius
- $D$  : External pipe diameter
- $t$  : Thickness of test assembly
- $L$  : Length

(2) The specimen also applies to longitudinal bend test for welding consumables for 9% Ni steel. The width of Specimen,  $b$ , is to be  $B+12$  where breath of weld,  $B$ , is 26 mm and over.

(3) For plates over 40 mm thick, the side bend specimen may be subdivided, each part being at least 20 mm wide and each part may be tested.

## 204. Mechanical testing procedures

### 1. Tensile test and impact test

Tensile tests and impact tests are to be carried out in accordance with the procedures prescribed in Ch 1, 203..

### 2. Bend test

- (1) Except where guided bend tests are required, bend test is roller bend test carried out by the jig of which the plunger has a bending radius specified in each Section with supporting rollers adjustable for their spans.
- (2) Guided bend test jigs are to be as shown in Figs 2.2.1 and 2.2.2.
- (3) Roller bend test jigs are to be as shown in Fig 2.2.3.

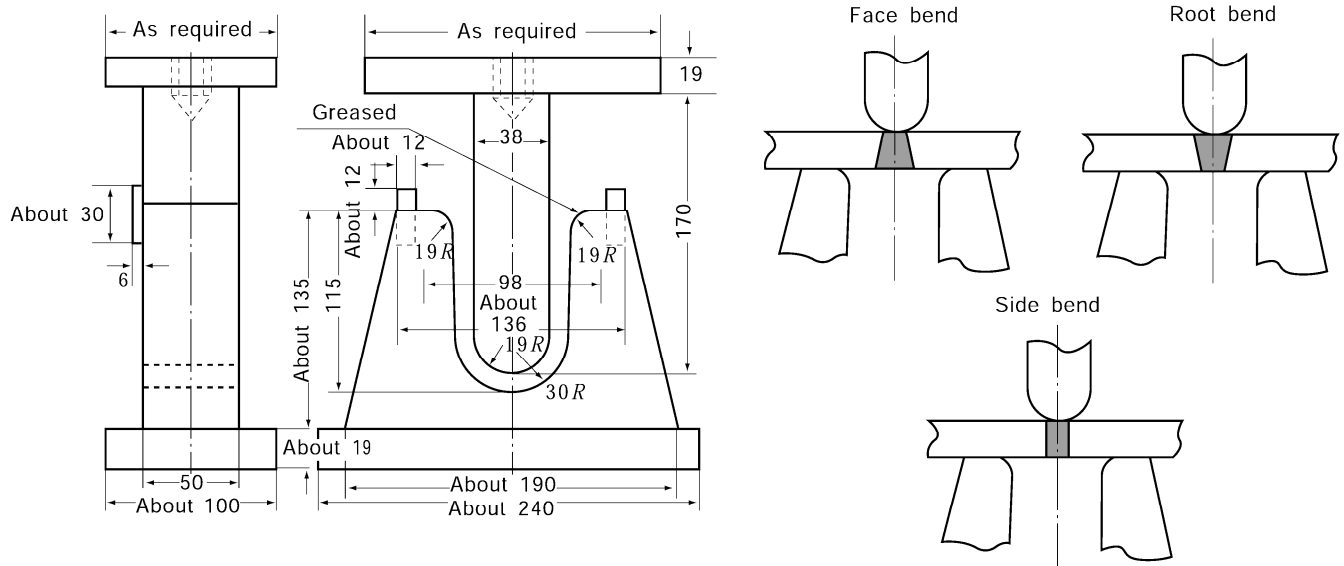


Fig 2.2.1 Guided Bend Test Jig (For 9mm in thick., Unit : mm)

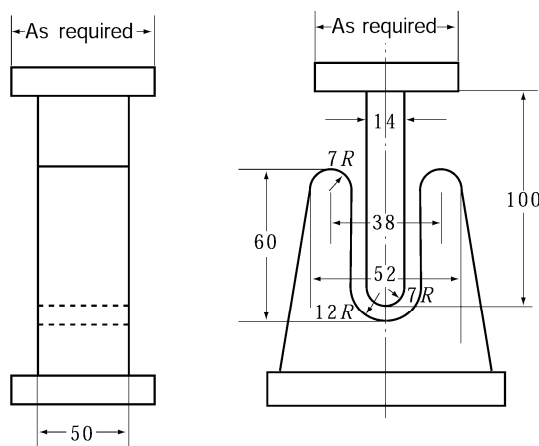


Fig 2.2.2 Guided Bend Test Jig  
(For 3.2mm in thick., Unit : mm)

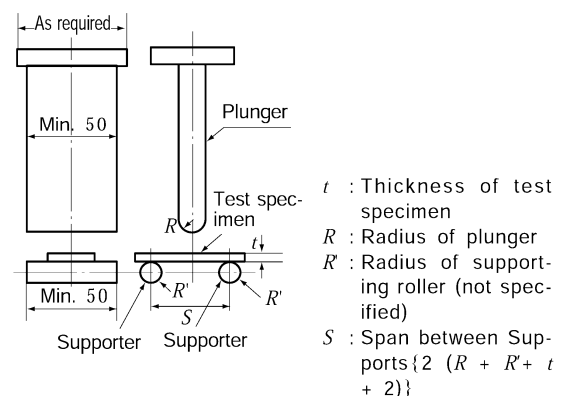


Fig 2.2.3 Jigs for Roller Bend Test (Unit : mm)

## Section 3 Welding Work and Inspection

### 301. Details of joints

#### 1. Application

The details of joints for manual welding are to be in accordance with the following Paragraphs. For other welding procedures such as automatic welding and in case where the specified details of joint are deemed unpracticable, full details of joint are to be submitted for approval.

#### 2. Butt joints

- (1) In general, edge preparations of butt welds are to be as shown in Fig 2.2.4.
- (2) Butt welded joints of plates having difference over 4 mm in thickness are to be properly tapered at the end of thicker plate.

#### 3. Butt joints of thick materials

The groove of thick materials, such as cast steel, is in general to be prepared as shown in Fig 2.2.5.

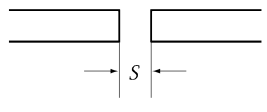
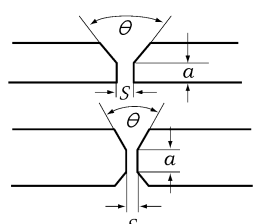
Thickness(mm)	Edge preparation	Dimensions
$t \leq 6.0$		$S \leq 3.0 \text{ mm}$
$t > 6.0$		$S \leq 5.0 \text{ mm}$ $a \leq 3.0 \text{ mm}$ $\theta \geq 50^\circ$

Fig 2.2.4 Edge preparation

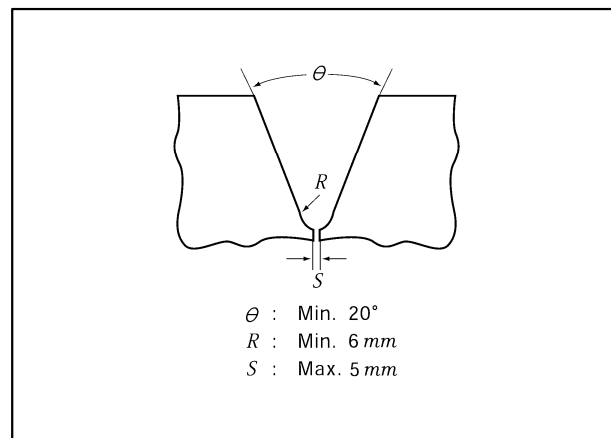


Fig 2.2.5 Butt Joint of Thick Material

#### 4. Lap joints

- (1) The breadth of overlap for lap joints which may be subjected to bending is not to be less than obtained from the following formula, but need not exceed 50 mm.

$$b = 2t + 25 \quad (\text{mm})$$

where:

$t$  = Thickness of the thinner plate (mm)

- (2) Where plates are joggled, the breadth of overlap for joints which may be subjected to bending is not to be less than obtained from the following formula, but need not exceed 40 mm.

$$b = t + 25 \quad (\text{mm})$$

where:

$t$  = Thickness of the thinner plate (mm).

### 302. Welding Practice

1. Welding Practice, which is the detailed statement of the general welding works for hull structure, is to contain welding process, standard of welding and its quality control, application of welding consumables, welding procedures specification(WPS) and welding sequence of main hull structure and be submitted to the Society.
2. The welding procedure specification(WPS) specified above is to be those satisfactorily complying with the welding procedure qualification tests specified in **Sec 4**.

### 303. Application of welding consumables

Welding consumables used for welded joints of hull structure are to be of the grades as specified in the relevant Articles of **Sec 6** according to the following requirements:

- (1) Application of welding consumables for welded joints of various grades of steel is to be as specified in **Table 2.2.3**.
- (2) Welding consumables for lower toughness of steel may be used for welded joints of different toughness of steel of the same specified strength.
- (3) In case of welding of steels of different specified strength, the welding consumables required for the steel of lower specified strength may be used, provided that adequate means for preventing cracks are considered.
- (4) It is recommended that controlled low hydrogen type consumables are to be used when joining higher strength structural steel to the same or lower strength level, except that other consumables may be used at the discretion of the Society when the carbon equivalent is below or equal to 0.41 %. When other than controlled low hydrogen type electrodes are used, appropriate procedure tests for hydrogen cracking may be conducted at the discretion of the Society.  
**[See Guidance]**

### 304. Preparation for Welding

#### 1. Edge preparation

- (1) The edge preparations are to be in accordance with the plans, and are to be free from moisture, grease, rust and paint which may cause injurious defects in welded joints.
- (2) The edges to be welded shall be smooth, uniform and free from notches, laminations, cracks and other discontinuities which would adversely affect the quality or strength of the weld.
- (3) Any injurious defects on the edges are to be removed. When weld repairs are required, controlled low hydrogen type welding consumables are to be used as far as practicable and grinding the complete weld smooth and flush with the adjacent surface.

#### 2. Tack welding

- (1) Tack welding is to be carried out by the welders qualified by the Society.
- (2) Tack welding is to be removed before the main welding for joints of strength deck plating, sheer strakes, shell plating, and other important structural members or is to be carried out by the same procedure as the main welding without injurious defect in welded joints and made with the same or higher grade of welding consumables as intended to use for main welding.
- (3) The minimum length and pitch of tack welds should be in accordance with the Guidance in relating to Rules. **[See Guidance]**
- (4) Injurious defects or any deviations from groove design due to tack welding to obstruct proceedings of main welding are to be completely removed.
- (5) In case of tack welding higher strength steels, high strength steels for welded structures or joining under high restraint, preheating is to be taken as necessary prior to tack welding.

#### 3. Fixtures

- (1) Setting appliances to be used for welding fabrications are to be so arranged as to give restraint without cracks and other defects in welded joints.
- (2) Tack welding for temporary fittings is not to leave any defect on base metal after the tack welds have been removed.



Table 2.2.3 Selection of welding consumables(rolled steel plates) (2017) (2019) (2021) (2022)

Kind and grade of steel to be welded		Grade of applicable welding consumables <sup>(1)</sup>	
Rolled steels for hull	Mild steel	A	1, 2, 3, 1Y, 2Y, 3Y, 4Y, 5Y, 2Y40, 3Y40, 4Y40, 5Y40, L1, L2, L3
		B, D	2, 3, 2Y, 3Y, 4Y, 5Y, 2Y40, 3Y40, 4Y40, 5Y40, L1, L2, L3
		E	3, 3Y, 4Y, 5Y, 3Y40, 4Y40, 5Y40, L1, L2, L3
	Higher strength low alloy steel	AH32, AH36	1Y <sup>(2)</sup> , 2Y, 3Y, 4Y, 5Y, 2Y40, 3Y40, 4Y40, 5Y40, L2 <sup>(3)</sup> , L3, 2Y42, 3Y42, 4Y42, 5Y42
		DH32, DH36	2Y, 3Y, 4Y, 5Y, 2Y40, 3Y40, 4Y40, 5Y40, L2 <sup>(3)</sup> , L3, 3Y42, 4Y42, 5Y42
		EH32, EH36	3Y, 4Y, 5Y, 3Y40, 4Y40, 5Y40, L2 <sup>(3)</sup> , L3, 4Y42, 5Y42
		FH32, FH36	4Y, 5Y, 4Y40, 5Y40, L2 <sup>(3)</sup> , L3, 4Y42, 5Y42
		AH40, DH40	2Y40, 3Y40, 4Y40, 5Y40, 3Y42, 4Y42, 5Y42, 2Y46, 3Y46, 4Y46, 5Y46
		EH40	3Y40, 4Y40, 5Y40, 3Y42, 4Y42, 5Y42, 3Y46, 4Y46, 5Y46
		FH40	4Y40, 5Y40, 4Y42, 5Y42, 4Y46, 5Y46
EH47-H	3Y47, 4Y46 <sup>(6)</sup> , 5Y46 <sup>(6)</sup>		
Rolled steels for low temperature services	RL235A	4Y, 4Y40, L1, L2, L3	
	RL235B, RL325A, RL325B	5Y42 <sup>(4)</sup> , L2, L3	
	RL355	5Y42, L3	
	RL5N390	L51, L91	
	RL9N490	L91	
High strength steels for welded structures <sup>(5)</sup>	AH43	2Y42, 3Y42, 4Y42, 5Y42, 2Y46, 3Y46, 4Y46, 5Y46, 2Y50, 3Y50, 4Y50, 5Y50	
	DH43	3Y42, 4Y42, 5Y42, 3Y46, 4Y46, 5Y46, 3Y50, 4Y50, 5Y50	
	EH43	4Y42, 5Y42, 4Y46, 5Y46, 4Y50, 5Y50	
	FH43	5Y42, 5Y46, 5Y50	
	AH47	2Y46, 3Y46, 4Y46, 5Y46, 2Y50, 3Y50, 4Y50, 5Y50	
	DH47	3Y46, 4Y46, 5Y46, 3Y50, 4Y50, 5Y50	
	EH47	4Y46, 5Y46, 4Y50, 5Y50	
	FH47	5Y46, 5Y50	
	AH51	2Y50, 3Y50, 4Y50, 5Y50, 2Y55, 3Y55, 4Y55, 5Y55	
	DH51	3Y50, 4Y50, 5Y50, 3Y55, 4Y55, 5Y55	
	EH51	4Y50, 5Y50, 4Y55, 5Y55	
	FH51	5Y50, 5Y55	
	AH56	2Y55, 3Y55, 4Y55, 5Y55, 2Y62, 3Y62, 4Y62, 5Y62	
	DH56	3Y55, 4Y55, 5Y55, 3Y62, 4Y62, 5Y62	
	EH56	4Y55, 5Y55, 4Y62, 5Y62	
	FH56	5Y55, 5Y62	
	AH63	2Y62, 3Y62, 4Y62, 5Y62, 2Y69, 3Y69, 4Y69, 5Y69	
	DH63	3Y62, 4Y62, 5Y62, 3Y69, 4Y69, 5Y69	
	EH63	4Y62, 5Y62, 4Y69, 5Y69	
	FH63	5Y62, 5Y69	
AH70	2Y69, 3Y69, 4Y69, 5Y69		
DH70	3Y69, 4Y69, 5Y69		
EH70	4Y69, 5Y69		
FH70	5Y69		

**Table 2.2.3 Selection of welding consumables(rolled steel plates) (2017) (2019) (2021) (2022) (Continued)**

Kind and grade of steel to be welded		Grade of applicable welding consumables <sup>(1)</sup>
High strength steels for welded structures <sup>(5)</sup>	AH90	2 Y89, 3 Y89, 4 Y89, 2 Y96, 3 Y96, 4 Y96
	DH90	3 Y89, 4 Y89, 3 Y96, 4 Y96
	EH90	4 Y89, 4 Y96
	AH97	2 Y96, 3 Y96, 4 Y96
	DH97	3 Y96, 4 Y96
	EH97	4 Y96

NOTES :

- (1) The symbol of welding consumables listed above show the materials which are specified in **Table 2.2.25, Table 2.2.35, Table 2.2.43, Table 2.2.49, and Table 2.2.77.**
- (2) When joining higher strength steels using Grade 1Y welding consumables, the material thicknesses should not exceed 25 mm.
- (3) Welding consumables of "L2" is applicable to steel grade of AH32, DH32, EH32 or FH32.
- (4) Welding consumables of "5Y42" is applicable to steel grade of RL325B.
- (5) Where the design requirements permit undermatching weld joint, then welding consumables within scope of 609. can be considered subject to Society discretion and Manufacturer's recommendations.
- (6) It can be used in accordance with the Guidance relating to the Rules specified by the Society.  
**【See Guidance】**

### 305. Welding sequence and direction of welding

1. Welding sequence and direction of welding are to be so determined as to prevent defects in welded joints and to minimize deformations caused by welding.
2. The joints which may cause excessive contraction by welding are to be welded as far as practicable prior to the joints which cause smaller contraction by welding.
3. Welding is to be proceeded to free ends of the joints as far as practicable and welding with direction of vertical-downward is not to be carried out, except the special approval of the Society.  
**【See Guidance】**

### 306. Main welding

1. Welding is to be carried out so that no injurious defects may exist in the joints.
2. Welding is to be carried out under conditions of protection against the deleterious effect of moisture, rain, wind and snow, and is to be preheated in cold weather if found necessary.**【See Guidance】**
3. The ends of important welded joints are to be fitted with run-off tabs or are to have proper extensions, which are to be cut off after finished welding.
4. Butt welded joints are to be back chipped to remove the defects in root of welds before applying the closing bead, except in case of one side welding or other approved procedures.
5. In case of welding under excessive restraint or welding for thick steel plate, cast steel or forged steel, special precaution is to be taken as necessary, such as preheating of the material, use of low hydrogen electrodes, etc. so as to prevent cracks.
6. In the parts subject to excessive stress concentration, the fillet welding is to be carried around the ends of member, but in other parts, the fillet welding may not be carried out around the ends, provided that the craters at the ends of welds are filled up.
7. Excessive gaps in butt joint are to be either deposited with welding on grooves, fitted with backing strips to the joints or partly replaced, and are not to be spanned with welding nor filled by slugging.
8. Where the gap between the members in fillet joints is not greater than 2 mm, the welding may be done with the given size of fillet. Where the gap is not less than 2 mm nor more than 5 mm, the welding is to be done with an increased size of fillet corresponding to the amount of gap. Where the gap exceeds 5 mm, the welding is to be done inserting a liner of suitable size or with a chill strip, or plates to be welded are to be partly renewed. **【See Guidance】**

9. Preheating, intermediate temperature and post heat treatment are to be carried out in accordance with the welding procedure approved beforehand or the special approval of the Society.

**【See Guidance】**

### 307. Automatic welding

1. The grooves for automatic welding are to be finished in specially accurate dimensions.
2. Automatic welding is to be carried out within the inclination approved in the welding procedure qualification test.
3. In the cross but joints of 16 mm or over in thickness, one joint is to be welded after the automatic welding of the other joint has been completed on both sides.
4. Special precaution is to be taken as necessary for the automatic welding of rimmed steel to prevent cracks.

### 308. Welding for higher strength steel

1. Arc strikes are to be avoided as far as practicable.
2. Short bead, min. length of repair welds and line heating temperature, etc. are to be in accordance with the Shipbuilding Quality Standard recognized by the Society.

### 309. Quality of welds

1. The weld is to have a regular and uniform surface and it to be reasonably free from excessive re-inforcements, injurious defects, such as undercuts, overlaps, etc.
2. Welded structures are to be reasonably free from welding deformation.
3. Non-destructive inspection is to be carried out for welded joints as the Guidance relating to the Rules specified elsewhere. **【See Guidance】**
4. The welding defects found in an appropriate non-destructive inspection including the visual inspection or watertight test are to be removed and corrected by rewelding.

### 310. Repairs

1. The removal of weld defects shall be done by gouging, grinding, chipping, etc. with such a manner that the remaining weld metal or base metal is not damaged, however oxygen gouging is not to be used in high strength steels for welded structures.
2. The removed weld defects parts are to be so machined as not to affect repair welding and repair welding shall be carried out with low hydrogen type welding consumables and an electrode preferably smaller than that used for making the original weld.
3. Members distorted by welding may be straightened by mechanical means or localized heat treatment, however in case of localized heat treatment, the temperature of heated areas is to be so limited as not to affect the mechanical properties of base metal.

### 311. Welding works for YP47 Steels (2021)

#### 1. Short bead

Short bead length for tack and repairs of welds by welding are not to be less than 50mm. In the case where  $P_{cm}$  is less than or equal to 0.19, 25mm of short bead length may be adopted with approval of the Society.

#### 2. Preheating

Preheating is to be 50°C or over when air temperature is 5°C or below. In the case where  $P_{cm}$  is less than or equal to 0.19 and the air temperature is below 5°C but above 0°C, alternative preheat-

ing requirements may be adopted with approval of the Society.

### 3. Others

- (1) Special care is to be paid to the final welding so that harmful defects do not remain.
- (2) Jig mountings are to be completely removed with no defects in general, otherwise the treatment of the mounting is to be accepted by the Society.

### 312. Welding works for Brittle crack arrest steels (2021)

Welding work (such as relevant welder's qualification, short bead, preheating, selection of welding consumable, etc.) for brittle crack arrest steels is to be in accordance with the relevant requirements for each steel grade excluding suffix "BCA1" or "BCA2".

## Section 4 Welding Procedure Qualification Tests

### 401. General

#### 1. Application

- (1) The welding procedures to be applied to hull construction, machinery and piping specified in this Chapter are to be those satisfactorily complying with the welding procedure qualification tests specified in this Section. (2019)
- (2) The welding procedures qualification test for cargo tank, secondary barriers and piping arrangements in ships carrying liquefied gases in bulk, and for the low-flashpoint fuels tank are to be in accordance with **Pt 7, Ch 5, Sec 6** of Rules and **Rules/Guidances for the Classification of Ships Using Low-flashpoint Fuels**. (2019)

#### 2. Definitions

- (1) Welding procedure specification(WPS)  
A specification of materials, detailed methods, welding parameters etc. to be applied in the welding of a particular joint.
- (2) Welding procedure qualification tests(WPQT)  
A test carried out in order to demonstrate that a weld made according to a specific welding procedure specification meets the given requirements.
- (3) Welding procedure qualification record(PQR)  
The record of the actual parameters employed during welding of the qualification test piece according to the requirement of (2), and results from the non-destructive inspection and mechanical testing.

#### 3. General requirements of WPQT

- (1) The manufacturers are to obtain the approval of the welding procedure qualifications before the welding works in the following case specified in (a) through (b)
  - (a) Where the welding procedure is first adopted for welding works specified in **1.** and as follows. (2019)
    - (i) Welding work for boiler, Class 1 and Class 2 pressure vessels
    - (ii) Welding work for principal components of machinery (the principal components specified in **Table 5.2.4** of **Pt 5, Ch 2** and **Ch 3** of the Rules) and piping system
    - (iii) Welding work using special materials
    - (iv) Welding work using special welding process
  - (b) Where the welding variables specified in **402. 2** (1) through (11) are changed beyond the extent of those described in the approved welding procedure specifications.
- (2) For the approval of welding procedure qualification, the preliminary welding procedure specification specified in **402.** is to be reviewed by the Society and the welding procedure qualification test is to be carried out with satisfactory results. Welding procedure specifications are to refer to the test conditions and test results achieved during welding procedure qualification testing.

### 402. Welding procedure specification

1. A welding procedure specification (WPS) is to be prepared by the shipyard or manufacturer which intends to perform the welding procedure qualification test. This document is also referred to as a preliminary welding procedure specification (pWPS). The shipyard or manufacturer is to submit to the Society a pWPS for review prior to the tests.
2. The pWPS can be modified and amended during procedure tests as deemed necessary however it is to define, at least, the following welding variables.
  - (1) Kind of base metal
  - (2) Nominal thickness or diameter range(dimensions)
  - (3) Welding process
  - (4) Joint or groove designs with tolerances
  - (5) Welding position(s) and direction of progression
  - (6) Welding consumables(grade, shielded gas, backing, flux, etc.)
  - (7) Electrical characteristics(ampereage, voltage and pole nature etc.)
  - (8) Travel speed and heat input ranges
  - (9) Preheat and maximum interpass temperature
  - (10) Post weld heat temperature (if any)
  - (11) Other conditions necessary for the welding procedure (ex. : welding speed, heat input etc.)
3. Welding consumables used in welding procedure qualification tests should be approved in accord-

ance with the requirements specified in **Sec 6** of the Rules.

4. In case that the test pieces welded according to the pWPS show unacceptable results the pWPS is to be adjusted by the shipyard or manufacturer. The new pWPS is to be prepared and the test pieces welded in accordance with the new pWPS.
5. The WPS is to be used as a basis for the production welds, and upon satisfactory completion of the tests based on the pWPS, the Society may approve it as a WPS. In case that a WPS is approved by the Society the approval range is to be in compliance with the requirements in **407**.

#### 403. Welding procedure qualification tests(WPQT)

1. Where procedure qualification test is required, the test assembly is to be welded in the same or similar environment and the qualification tests are to be carried out under the welding conditions given in the pWPS.
2. Welding of the test assemblies and testing of test specimens are to be witnessed by the Surveyor.
3. The laboratory or testing establishment used to perform the tests is to have the necessary equipment, maintained in good order and suitably calibrated. And **Pt 2, Ch 1, 201**. of Rules is applied on those. (2019)
4. If tack welds and/or start and stop points are a condition of the weld process they are to be fused into the joint and are to be included in the test assemblies.
5. For qualification tests for stainless clad steels, the requirements specified in **404**. and **405**. are to be complied with. However the impact test may be dispensed with where other welding procedure qualification on the stainless clad steel base metal under the same welding condition has been approved. Where materials other than those specified in this Section are used, the qualification tests are to be carried out in accordance with the testing standard approved by the Society. Duplex stainless steel is to be in accordance with the Guidance in relating to Rules.
6. Where materials other than those specified in this Section are used, the qualification tests are to be carried out in accordance with the testing standard approved by the Society. Duplex stainless steel is to be in accordance with the Guidance in relating to Rules. **【See Guidance】**
7. Tests or test conditions other than those specified in this Section for the welding procedure qualification may be required, where deemed necessary by the Society.
8. Where Welding Procedure Specification (WPS) for the non-BCA steels has been approved by the Society, the said WPS is applicable to the same welding procedure applied to the same grade with suffix "BCA1" or "BCA2" except high heat input processes over 50kJ/cm. The requirements for welding procedure qualification test for brittle crack arrest steels is to be in accordance with the relevant requirements for each steel grade excluding suffix "BCA1" or "BCA2", except for hardness specified in **404. 9** and **405. 6**. (2021)

#### 404. Tests for butt welded joints

##### 1. Application

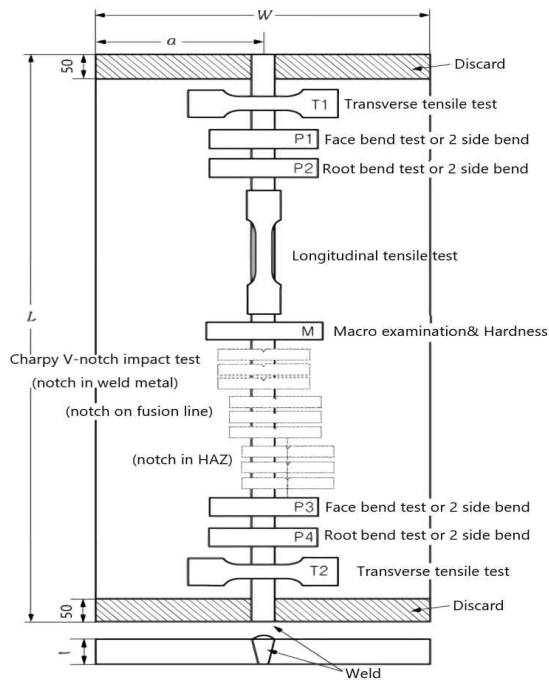
The requirements stated hereunder apply to the butt joints welded by manual welding, semi-automatic welding or automatic welding.

##### 2. Kinds of test

According to the materials to be tested, kinds of test and number of test specimens are to be given in **Table 2.2.4** and **Table 2.2.5**. Additional test may be required where found necessary by the Society. **【See Guidance】**

##### 3. Test assemblies

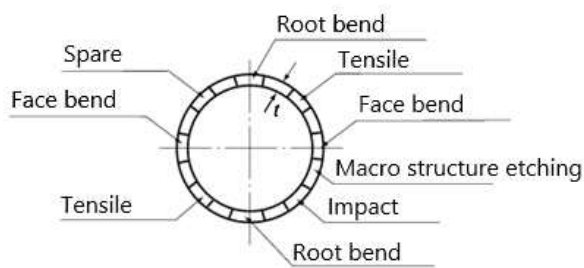
- (1) Test assemblies are to be prepared with the same or equivalent material used in the actual work.
- (2) The dimensions and types of test assembly are to be as indicated in **Fig 2.2.6**.



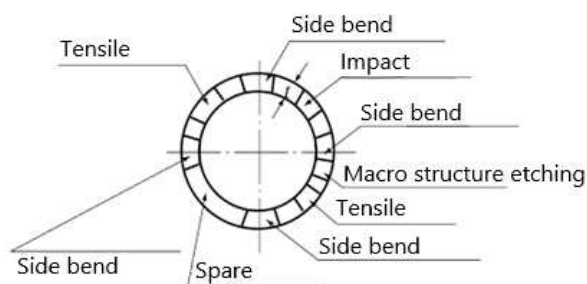
(Note)  
The test assembly is to be of a size with the minimum dimensions:  
(1) manual or semi-automatic welding:  
Width( $W$ ) : min. 300mm  
Length( $L$ ) : min. 350mm  
(2) automatic welding  
Width( $W$ ) : min. 400mm  
Length( $L$ ) : min. 1,000mm

(A) Test assembly for Hull Structural Steels, High Strength Quenching and Tempered Steels, Stainless Steels, Rolled steels for boiler/pressure vessel/low temp' service or Aluminium Alloys (2019)

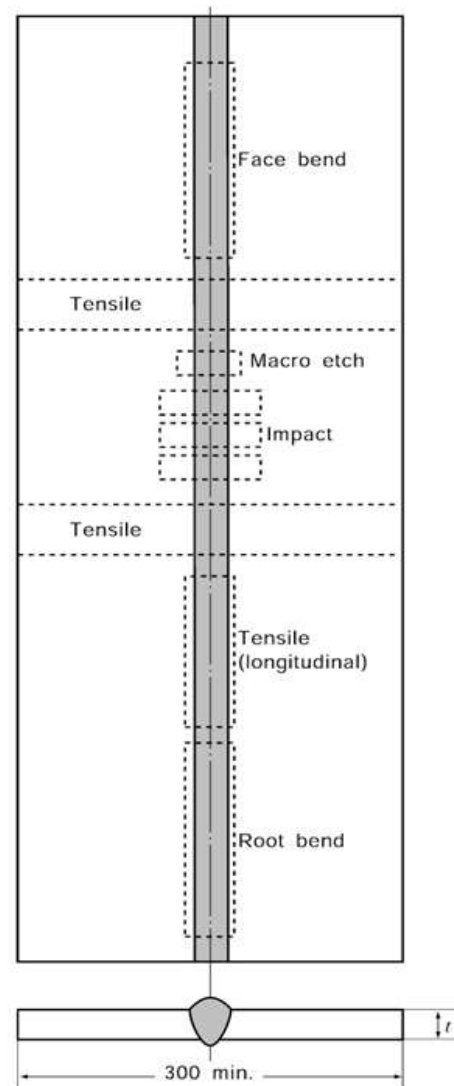
Fig 2.2.6 Welding procedure test assembly (Unit : mm)



(B) Test assembly for pipes less than 12mm in thickness



(C) Test assembly for pipes 12mm and over in thickness



(Note)

If base material and weld metal have not markedly different strength levels, two transverse bend specimens may alternatively be tested for two longitudinal bend specimens. (2019)

(D) Test assembly for RL9N490

**Fig 2.2.6 Welding procedure test assembly** (Unit : mm) (cont'd) (2022)

- (3) Test assemblies are to be welded in the same welding positions as the actual work.
- (4) When the test for plate is approved, the welding for the pipes over 500 mm in outer diameter is permitted. And when the test for pipes over 25 mm is approved, the welding for the plates is permitted. (2019)
- (5) For butt welded joints of rolled steel plates, the direction of welding according to rolling direction is to be as follows.
  - (a) When steel plates impact tested in longitudinal direction are used for test assemblies, the direction of welding of test assembly is perpendicular to the rolling direction of the two plates.
  - (b) When steel plates impact tested in transverse direction are used for test assemblies, the direction of welding of test assembly is parallel to the rolling direction of the two plates.



4. Tensile tests

(1) The number of tensile test specimens taken from each test assembly is to be as shown in Table 2.2.4 and Table 2.2.5. (2019)

Table 2.2.4 Kinds of Test for Plates with Butt Welded Joints (2019)

Grades and material symbols of test specimens			Kinds and number of specimens for test <sup>(1)</sup>							
			Visual insp.	Tensile test	Bend test	Impact test	Macro-structure insp.	Hard. test	Non-destructive insp. <sup>(4)</sup>	Brittle fracture initiation test
Rolled steels for hull structural	Normal strength steel	<i>A, B, D, E</i>		2	4 <sup>(2)</sup>			-		
	Higher strength steel	<i>AH32, DH32, EH32, FH32, AH36, DH36, EH36, FH36, AH40, DH40, EH40, FH40</i> <i>EH47-H</i>						1 <sup>(10)</sup>		
Rolled steels for low temperature service		<i>RL235A, RL235B, RL325A, RL325B, RL355, RL1N355, RL2N255, RL3N355, RL5N390</i> <i>RL9N490</i>		3 <sup>(5)</sup>	2	(3)		1		
Weldable high strength steel		<i>AH43, DH43, EH43, FH43, AH47, DH47, EH47, FH47, AH51, DH51, EH51, FH51, AH56, DH56, EH56, FH56, AH63, DH63, EH63, FH63, AH70, DH70, EH70, FH70, AH90, DH90, EH90, AH97, DH97, EH97</i>			4 <sup>(2)</sup>					1
Casting for welded construction and Hull steel forging		<i>RSC410, RSC450, RSC480, RSC520, RSC560, RSC600, RSC440A, RSC480A, RSC550A, RSF410H, RSF450H, RSF480H, RSF520H, RSF560H, RSF600H, RSF550AH, RSF600AH, RSF650AH</i>	Welding positions of whole length			(3)(9)	1	Welding positions of whole length		
Rolled stainless steels		<i>RSTS304, RSTS304L, RSTS304M, RSTS304N2, RSTS304LN, RSTS309S, RSTS310S, RSTS316, RSTS316L, RSTS316N, RSTS316LN, RSTS317, RSTS317L, RSTS317LN, RSTS321, RSTS347</i>			2					2
Aluminium alloys <sup>(6)</sup>	5000 series	<i>5083P, 5383P, 5059P, 5086P, 5754P, 5083S, 5383S, 5059S, 5086S<sup>(7)</sup></i>								
	6000 series	<i>6005AS, 6061S, 6082S<sup>(8)</sup></i>								
Rolled steel plates for boiler & pressure vessel	Boiler and class 1 pressure vessel <sup>(11)</sup>	<i>RSP24, RSP30, RSP32, RSP30A, RSP32A, RPV24, RPV32, RPV36, RPV42, RPV46, RPV50, etc.</i>		4 <sup>(2)</sup>	3 set <sup>(12)</sup>			1		
	Class 2 pressure vessel <sup>(11)</sup>									
	Class 3 pressure vessel <sup>(11)</sup>									
The tests may be omitted according to the discretion of the Society										

NOTES:

- (1) Where found necessary by the Society, microscopic test, hardness test and tests other than these may be required. **[See Guidance]**
- (2) Two root and two face bend specimens are to be tested. For thickness 12 mm and over, four side bend specimens may alternatively be tested. Where rolled steel plates for boiler & pressure vessel were tested, four side bend specimens may alternatively be tested for two root and two face bend specimens.
- (3) No. of test sets and position of notch are as shown in **Fig 2.2.7**.
- (4) Internal inspections by radiographic examination or ultrasonic examination and surface inspections by magnetic particle examination or liquid penetrant examination are to be carried out. Where rolled steel plates for boiler & pressure vessel were tested, radiographic examination is to be carried out for internal inspections.
- (5) Two specimens are to be taken transversely and one specimen is to be taken longitudinally (See **Fig 2.2.6**)
- (6) Material symbols of aluminium alloys include the symbols of which is the temper condition.
- (7) Rolled products which have the same grade and temp condition may be used.
- (8) Other rolled aluminium alloys of 6000 series with minimum tensile strength  $260 \text{ N/mm}^2$  may be used.
- (9) Where impact test is required.
- (10) Hardness test ( $H_v 10$ ) is required for hull structural steel with specified minimum yield strength of  $R_{eH} \geq 355 \text{ N/mm}^2$
- (11) The classification for pressure vessel is in accordance with **Pt 5, Ch 5**.
- (12) The positions of notches are a,b,c in **Fig 2.2.7**.
- (13) Deep notch test or CTOD test may be required. However brittle fracture test may be waived for the welding procedure of heat input less than  $200 \text{ kJ/cm}$ .

Table 2.2.5 Kinds of Test for Pipes with Butt Welded Joints (2019)

Grades and material symbols of test specimens		Kinds and number of specimens for test <sup>(1)(2)(3)</sup>						
		Visual insp.	Tensile test	Bend test <sup>(5)</sup>	Impact test <sup>(6)</sup>	Macro-structure insp.	Hard. test	Non-destructive insp.
The pipes for ordinary piping	<i>RSTH 35, RSTH 42, RSTH 52, RSTH 12, RSTH 22, RSTH 23, RSTH 24,</i>	Welding positions of whole length	2	4	-	1	1	Welding positions of whole length <sup>(9)</sup>
The pipes used for high temperature and high pressure <sup>(4)</sup>	<i>RST 138, RST 142, RST 238, RST 242, RST 249, RST 338, RST 342, RST 349, RST 412, RST 422, RST 423, RST 424, RBH 1, RBH 2, RBH 3, RBH 4, RBH 5, RBH 6, etc.</i>				(7)			
Steel pipes for low temperature service	<i>RLPA, RLPB, RLPC, RLP2, RLP3, RLP9</i>				(8)			Welding positions of whole length <sup>(10)</sup>
Stainless steel pipes	<i>RSTS 304TP, RSTS 304LTP, RSTS 309STP, RSTS 310STP, RSTS 316TP, RSTS 316LTP, RSTS 317TP, RSTS 317LTP, RSTS 321TP, RSTS 347TP</i>				-		-	

Notes :

- (1) Where found necessary by the Society, microscopic test, hardness test and tests other than these may be required. **【See Guidance】**
- (2) Regardless of the above, as for those of less than 50 mm in outer diameter, test assemblies are to be prepared by two sets, one for tensile test, the other for macro, micro structure and hardness distribution examinations to be carried out respectively.
- (3) For the welding procedure qualification tests on materials used at high temperature, the Society may require a creep test or high temperature tensile test.
- (4) For steam pipes and flanges to be used in the place where the design pressure is not less than 30 kgf/cm<sup>2</sup> and the design temperature exceeds 400°C.
- (5) Two root and two face bend specimens are to be tested. For thickness 12 mm and over, four side bend specimens may alternatively be tested. Where preparation of the above test specimens is not possible depending on pipe's diameter, test specimens for face bend test and root bend test may be reduced to one specimen each for those of 12 mm thickness or less, and for side bend test may be reduced to two specimens for those of over 12 mm. (2022) (2023)
- (6) In a case where preparation of impact test specimens is not possible depending on pipe's dimensions or in case where welding is made with a base metal having no impact value required, impact test may be omitted subject to the approval of the Society.
- (7) The position of notch is "a" in Fig 2.2.7.
- (8) Position of notch is as shown in Fig 2.2.7.
- (9) For those with an outer diameter of 130 mm or above, and with a design working pressure 30 kgf/cm<sup>2</sup> or above, and further with maximum design temperature over 400°C. However, even for the pipes having an outer diameter of less than 130 mm, radiographic examination depending on material and working condition may be required.
- (10) Internal inspections by radiographic examination or ultrasonic examination and surface inspections by magnetic particle examination or liquid penetrant examination are to be carried out.

Table 2.2.6 Tensile Test Requirements for Butt Welded Joint

Kind of testing materials	Grade of testing materials	Tensile strength (N/mm <sup>2</sup> )	Yield strength (N/mm <sup>2</sup> )
Rolled steels for lower temperature service	RL 9M490	590 min. <sup>(1)</sup>	315 min.
		630 min. <sup>(2)</sup>	–
Steel pipes for low temperature service	RLP9	630 min.	–
Aluminium alloys	5754	190 min.	–
	5086	240 min.	–
	5083	275 min.	–
	5383	290 min.	–
	5059	330 min.	–
	6005A, 6061, 6082 <sup>(3)</sup>	170 min.	–

(Notes)  
 (1) For test specimen in longitudinal direction  
 (2) For test specimen in transverse direction  
 (3) See notes (8) of Table 2.2.4.

(2) Tensile tests are to be carried out with the test specimen shown in Table 2.2.1. The tensile strength is not to be less than the minimum tensile strength specified for the base metal except for those specified in Table 2.2.6. When butt welds are made between plates of different grades, the tensile strength to be obtained on the welded assembly is to be in accordance with the requirements relating to the steel grade having lower strength. In this case, "lower strength grade of steel" means grade E of Fig 2.2.7, (2). (2019)

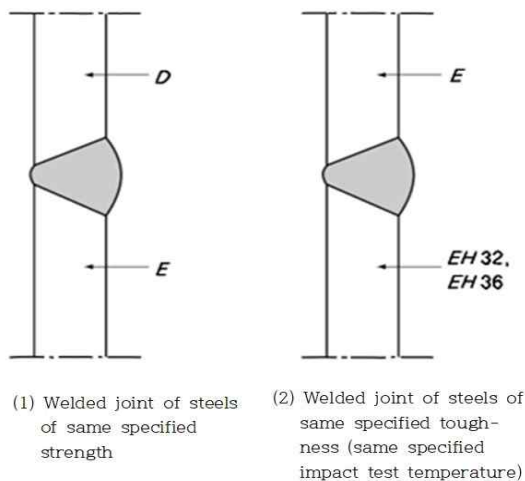


Fig 2.2.7 Butt Welds between Different Steel Grades (2019)

(3) In following cases where the consumables are not unavoidably approved by the Society, it is to be required additionally to prepare a R14A deposited metal tensile test specimen as shown in Table 2.2.1 in entirely weld metal and the tensile properties recorded for each specimen are not to be less than the minimum required for the approval of the appropriate grade of consumable.

(a) For the urgency of the corresponding work schedule

(b) For a small quantity of welding consumables with the rare frequency of the survey in future

Unless the welding consumables are approved by the Society, the Welding Procedure Specification is to be deemed valid only for same Lot with welding consumables used. And the

Lot no. is to be stated in the Welding Procedure Specification. (2019)

- (4) Where more than one welding process or type of consumable has been used to make the test weld, test specimens are to be taken from the area of the weld where each was used with the exception of those processes or consumables used to make the first weld run or root deposit.

### 5. Bend tests

- (1) The number of bend test specimens taken from each test assembly is to be as shown in **Table 2.2.4** and **Table 2.2.5**, and the position of specimen is to be as shown in **Fig 2.2.6**.
- (2) The shape and dimension of face bend specimen, root bend specimen or side bend specimen are to be as indicated in *RB1*, *RB2* or *RB3* of **Table 2.2.2**. Bend test procedure and inside bend diameter are to be as indicated in **Table 2.2.7**. There is to be no crack nor any other defect greater than 3 mm in length in any direction on the surface of bend specimen. (2018)
- (3) For butt joints in heterogeneous base metals, face and root longitudinal bend test specimens may be used instead of the transverse bend test specimens. (2019)

**Table 2.2.7 Bend Test Requirements (2018)**

Kind of testing materials	Grade of testing materials	Inside bend diameter (mm) <sup>(1)</sup>	Bending angle
Steel pipes for low temperature service	<i>RLP9</i>	$\frac{20}{3}t$	180°
Weldable high strength steel	<i>AH43, DH43, EH43, FH43, AH47, DH47, EH47, FH47, AH51, DH51, EH51, FH51</i>	$5t$	
	<i>AH56, DH56, EH56, FH56, AH63, DH63, EH63, FH63, AH70, DH70, EH70, FH70</i>	$6t$	
Aluminium alloys	5754, 5086, 5083, 5383, 5059, 6005A, 6061, 6082 <sup>(2)</sup>	(3)	
Other materials		$4t$	
<p>NOTES :</p> <p>(1) <math>t</math> is the thickness of the test specimen.</p> <p>(2) See Notes (9) of the <b>Table 2.2.4</b>.</p> <p>(3) The bend test specimens should be bent on a mandrel with maximum diameter as given in the formula below.</p> $d = \frac{100 \times t_s}{A} - t_s$ <p>where <math>d</math> is the maximum former diameter  <math>t_s</math> is the thickness of the bend test specimen (this includes side bends)  <math>A</math> is the minimum tensile elongation required by the alloy grade, temper condition and thickness (for combination between different alloys, the lowest individual value should be used).</p>			

### 6. Impact tests

- (1) *Normal and higher strength hull structural steels*
- (a) The test specimen is to be charpy V-notch impact test specimen as shown in **Table 2.1.3** and to be taken from the position in **Fig 2.2.6**.
- (b) The number of test specimens taken from test assemblies and the position of notch for the test specimen are as specified in **Fig 2.2.8**.
- (c) Test specimen is to be sampled from 1 to 2 mm below the surface of the base metal, transverse to the weld and on the side containing the last weld run.
- (d) Test temperature and absorbed energy are to be in accordance with **Table 2.2.8**.

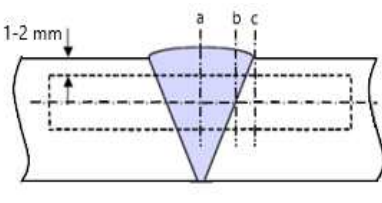
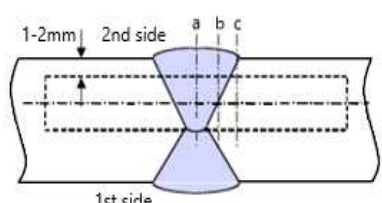
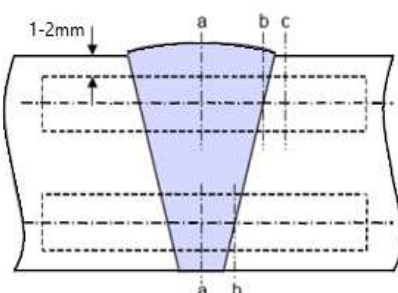
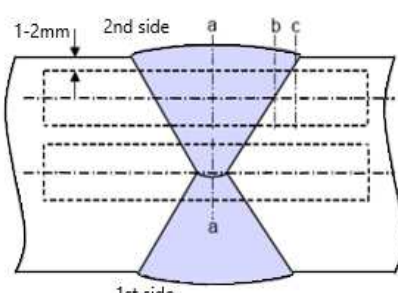
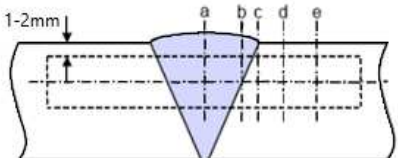
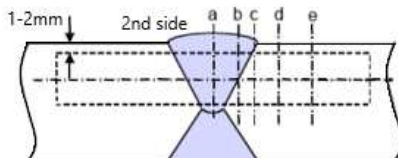
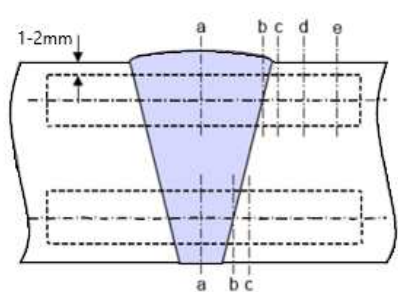
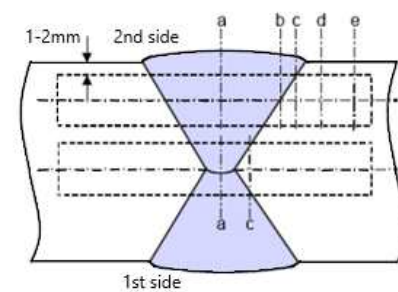
Table 2.2.8 Impact test requirements for butt joints ( $t \leq 50$  mm) <sup>(1),(2)</sup> (2019)

Grade of steel	Test temp. (°C)	Value of minimum average absorbed energy (J) <sup>(4)</sup>		
		For manually or semi-automatically welded joints		For automatically welded joints
		Downhand, Horizontal, Overhead	Vertical upward, Vertical downward	
<i>A</i> <sup>(3)</sup>	20	47 min.	34 min.	34 min.
<i>B</i> <sup>(3)</sup> , <i>D</i>	0			
<i>E</i>	-20			
<i>AH</i> 32, <i>AH</i> 36	20			
<i>DH</i> 32, <i>DH</i> 36	0			
<i>EH</i> 32, <i>EH</i> 36	-20			
<i>FH</i> 32, <i>FH</i> 36	-40			
<i>AH</i> 40	20	39 min.	39 min.	39 min.
<i>DH</i> 40	0			
<i>EH</i> 40	-20			
<i>FH</i> 40	-40			
<i>EH</i> 47-H ( $t > 50$ mm)	-20	64 min.		

Note:

- (1) For thickness above 50 mm other than EH47-H, impact test requirements are to be agreed by the Society. **【See Guidance】**
- (2) These requirements are to apply to test piece of which butt weld is perpendicular to the rolling direction of the plates.
- (3) For Grade A and B steels average absorbed energy on fusion line and in heat affected zone is to be minimum 27 J.
- (4) When the absorbed energy of two or more test specimens among a set of test specimens is less in value than the specified average absorbed energy or when the absorbed energy of a single test specimen is less in value than 70 % of the specified average absorbed energy, the test is considered to have failed.

- (e) When butt welds are made between different steel grades/types, the test specimens are to be taken from the side of the joint with lower toughness of steel. Temperature and absorbed energy results are to be in accordance with the requirements for the lower toughness steel. In this case, "lower toughness grade of steel" means grade *D* of **Fig 2.2.7**, (1). (2019)
  - (f) Where more than one welding process or consumable has been used to make the test weld, impact test specimens are to be taken from the respective areas where each was employed. This is not to apply to the process or consumables used solely to make the first weld run or root deposit.
  - (g) Where the weld metal cross-section size or shape does not allow the charpy V-notch impact test specimen to be in deposited metal, the requirements in **202. 3** of **Ch 1** are to be applied.
- (2) *High strength steels for welded structures*
    - (a) Impact test is to be performed as described in the above (1).
    - (b) Test temperature and absorbed energy are to be in accordance with the requirements of base metal
  - (3) *Weldable C and C-Mn hull steel castings and forgings*  
For base metal with specified impact values test temperature and absorbed energy are to be in accordance with the requirements of the base metal to be welded.

heat input	thickness	Locations of V-notch <sup>(3)</sup>	
normal heat input $\leq 50 \text{ kJ/cm}$	$t \leq 50 \text{ mm}^{(1)}$		
	$t > 50 \text{ mm}$		
high heat input $> 50 \text{ kJ/cm}$	$t \leq 50 \text{ mm}^{(2)}$		
	$t > 50 \text{ mm}$		

Note:

- (1) For one side single run welding over 20 mm notch location "a" is to be added on root side.
- (2) For one side welding with thickness over 20 mm notch locations "a", "b" and "c" are to be added on root side.
- (3) Notch locations:
  - a : center of weld "WM"
  - b : on fusion line "FL"
  - c : in HAZ, 2 mm from fusion line
  - d : in HAZ, 5 mm from fusion line
  - e : in HAZ, 10 mm from fusion line in case of heat input  $> 200 \text{ kJ/cm}$

Fig 2.2.8 No. of test sets and locations of V-notch

- (4) *Steels & Pipes for low temperature Service (2019)*
  - (a) The test specimen is to be Charpy V-notch impact test specimen as shown in **Table 2.1.3** and to be taken from the position in **Fig 2.2.8**.
  - (b) The number of test specimens taken from test assemblies, the position of notch for the test specimen, test temperature and absorbed energy are as specified in **Table 2.2.9**.
- (5) *Rolled steel plates for boiler and class 1 pressure vessel (2019)*
  - (a) Impact test is to be performed as described in the above (1). The locations of notches are "a,b,c" of **Fig 2.2.8**.

- (b) Test temperature and absorbed energy are to be in accordance with the requirements of base metal.
- (6) *Pipes for high temperature and high pressure (2019)*
  - (a) Impact test is to be performed as described in the above (1). The location of notch is “a” of **Fig 2.2.8**.
  - (b) Test temperature and absorbed energy are to be in accordance with the requirements of base metal.

#### 7. Macro-structure inspection

- (1) The test specimens are to be prepared and etched on one side to clearly reveal the weld metal, the fusion line and the heat affected zone. Macro examination is to include about 10 mm unaffected base metal.
- (2) The examination is to reveal a regular weld profile, through fusion between adjacent layers of weld and base metal and the absence of defects such as cracks, lack of fusion etc.

#### 8. Visual & Non-destructive inspection

- (1) Test assemblies are to be examined for the whole length(excepting discard area of test assembly of **Fig 2.2.6**) by visual and by non-destructive testing prior to the cutting of test specimen. Visual and non-destructive examinations should be carried out after any required post weld heat treatment, natural or artificial ageing, and prior to the cutting of the test specimens. (2019)
- (2) For weldable high strength steels with specified minimum yield strength of 420 N/mm<sup>2</sup> and above the visual and non-destructive testing are to be delayed for a minimum of 48 hrs, unless heat treatment has been carried out. (2019)



**Table 2.2.9 Impact Test Requirements for Butt Welded Joint (Steels for low temperature Service) (2019)**

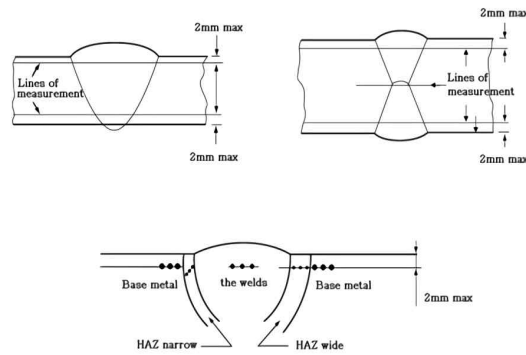
Grade of steel	Test temp. (°C)	$A^{(1)}$	$B, C, D, E^{(1)}$	
		Value of average absorbed energy(J) <sup>(3)</sup>	Value of average absorbed energy(J) <sup>(3)</sup>	
			$L^{(2)}$	$T^{(2)}$
<i>RL 235A</i>	-40	27 min.	41 min.	27 min.
<i>RL 235B</i>	-50			
<i>RL 325A</i>	-50			
<i>RL 325B</i>	-60			
<i>RL 355</i>	-60			
<i>RL 1N355</i>	-80			
<i>RL 2N255</i>	-70			
<i>RL 3N355</i>	-100			
<i>RL 5N390</i>	-120			
<i>RL 9N490</i>	-196			
<i>RLPA</i>	-40	-	-	-
<i>RLPB</i>	-50			
<i>RLPC</i>	-60			
<i>RLP2</i>	-70			
<i>RLP3</i>	-95			
<i>RLP9</i>	-196	27 min.	34 min.	-
			41 min.	

NOTES:  
 (1) Position of notch as shown in **Fig 2.2.7**.  
 (2) L(or T) indicates that the direction of welding is transverse (or parallel) to the rolling direction of test materials.  
 (3) When the absorbed energy of two or more test specimens among a set of test specimens is less in value than the specified average absorbed energy or when the absorbed energy of a single test specimen is less in value than 70% of the specified average absorbed energy, the test is considered to have failed.

- (3) NDT procedures are to be agreed with the Society. The results of non-destructive testing are to show that there are no cracks or other injurious defects.
- (4) Acceptance criteria is to be in accordance with the relevant requirements of the relevant Rules as follows. However, if agreed by the Society, imperfections detected by visual or non-destructive testing may be assessed in accordance with *ISO 5817*, class B, except for imperfection type such as excess weld metal and excess penetration for which level C applies (2019)
  - (a) Rolled steels for hull – **Annex 2-7**
  - (b) High strength steels for welded structures – **Annex 2-7** or **Pt 7, Ch 5** of the Rules
  - (c) Rolled steels for low temperature service – **Pt 7, Ch 5** of the Rules
  - (d) Materials for machinery installation(boilers, pressure vessel and piping system) – **Pt 5, Ch 5** or **Ch 6** of the Rules
- (5) For aluminium alloys, imperfections detected by visual or non-destructive testing should be assessed in accordance with **ISO 10042:2018**, level B, except for excess weld metal or convexity, excess throat thickness and excess of penetration for which the level C applies. (2022) (2023)

**9. Hardness test (2019)**

- (1) Hardness distribution at positions shown in **Fig 2.2.9** is to be measured.



Note

1. Measuring load is to be 10 kg vickers and measuring intervals are to be 1 mm.
2. For *EHA7-H* and brittle crack arrest(BCA) steels, measurement points are to include mid-thickness position in addition. (2021)

**Fig 2.2.9 Hardness Test for butt welded joint  
(Units : mm)**

(2) The results from the hardness test are to be in accordance with **Table 2.2.10**. (2019)

**Table 2.2.10 Hardness Test Requirements for Butt Welded Joint (2019) (2021)**

Grades and material symbols of test specimens		Hardness (Hv10)
Rolled steels for hull structural	<i>AH 36, DH 36, EH 36, FH 36, AH 40, DH 40, EH 40, FH 40, EH47-H</i>	350 max.
	<i>EHA7-H-BCA1/2</i>	380 max.
Weldable high strength steel	<i>AH 43 ~ FH 70</i>	420 max.
	<i>AH 90, DH 90, EH 90, AH 97, DH 97, EH 97</i>	450 max.
Rolled steels & Steel pipes for low temperature service	<i>RL 235A, RL 235B, RL 325A, RL 325B, RLPA, RLPB, RLPC</i>	380 max.
	<i>RL 355</i>	450 max.
	<i>RL 1N355, RL 2N255, RLP 2</i>	350 max.
	<i>RL 3N355, RL 5N390, RLP 3</i>	450 max.
<i>RL 9N490, RLP 9</i>		
Rolled steel plates for boiler & pressure vessel The pipes for ordinary piping The pipes used for high temperature and high pressure		380 max.

**10. Brittle fracture initiation test (2019)**

- (1) Test assemblies are to be welded for highest heat input and lowest heat input position and all applicable tests are to be made on those assemblies.
- (2) Test method and acceptance criteria
  - (a) Deep notch test or Crack Tip Opening Displacement (CTOD) test is to be carried out and the result is to be reported.
  - (b) CTOD test is to be carried out in accordance with *ISO 15653* or equivalent.
  - (c) When performing the deep notch test, manufacturer is to submit the detailed test procedure to the Society.
  - (d) Manufacturer is to be consulted with the Society the dimension of test specimen, test condition, etc.

**405. Tests for fillet welded joints**

**1. Application**

The requirements stated hereunder apply to the fillet joints welded by manual, semi-automatic or automatic welding in any welding position.

**2. Kinds of test**

The kinds of test and number of test specimens are to be given in **Table 2.2.11** and **Table 2.2.12**. The kinds of test for machinery installations are to be in accordance with **Table 2.2.11**. Additional tests may be required if found necessary by the Society. (2019) (2023) **[See Guidance]**

**Table 2.2.11 Kinds of Test for fillet welded joints<sup>(1)</sup> (2023)**

Kinds and number of specimens for test				
Visual insp.	Surface crack detection	Macro-structure insp.	Hard. test <sup>(2)</sup>	fracture test
Welding positions of whole length	Welding positions of whole length :NDT for surface (MT or PT)	2 <sup>(3)</sup>	1	2
(Notes) (1) Kinds of test for machinery installation's fillet welded joints are in accordance with <b>Table 2.2.12</b> . (2) The materials required hardness test in <b>Table 2.2.4</b> are to be tested. (3) In case of other than rolled steels for hull structural, weldable high strength steel, and aluminium alloy, one specimen is to be taken.				

Table 2.2.12 Kinds of Test for machinery installations's fillet welded joints (2019) (2023)

Divisions		Kinds of test and number of specimens taken from test assemblies (1)(2)				
		Macro-structure inspection	Visual insp.	Surface crack detection	Hard. test	Fracture test
Welding of boiler and pressure vessel	Boiler and class 1 pressure vessel	1	Welding positions of whole length	Welding positions of whole length :NDT for surface (MT or PT)	-	2
	Class 2 pressure vessel					
	Class 3 pressure vessel					
Welding of piping	The steel pipes for low temperature service	2	Welding positions of whole length	Welding positions of whole length :NDT for surface (MT or PT)	1	2
	Stainless steel pipes				-	
	The pipes for ordinary piping					
	The pipes used for high temperature and high pressure <sup>(3)</sup>					

Notes :

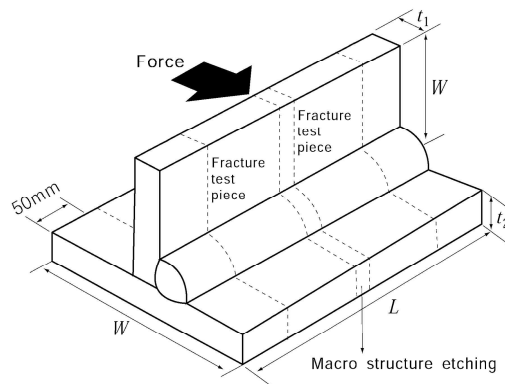
(1) In a case where special materials are used, special welding procedure is employed or where deemed necessary by the Society, the other tests or test conditions than those specified in this Section for the welding procedure qualification may be required

(2) For the welding procedure qualification tests on materials used at high temperature, the Society may require a creep test or high temperature tensile test.

(3) For steam pipes and flanges to be used in the place where the design pressure is not less than 30 kgf/cm<sup>2</sup> and the design temperature exceeds 400°C.

### 3. Test assemblies and welding

- (1) Test assembly is to be prepared with the same or equivalent material used in the actual work.
- (2) Dimensions and type of test assembly are to be as indicated **Fig 2.2.10** and **Fig 2.2.11**.



NOTES :

1. The length of test specimen is as follows :
  - (1) Manual and semi-automatic welding : Width  $W=3 \times t$ , min.150 mm, Length  $L=6 \times t$ , min.350 mm
  - (2) Automatic welding : Width  $W=3 \times t$ , min.150 mm, Length  $L=\text{min.}1000$  mm
2. Thickness of webs and flanges of the test assembly,  $t_1$  and  $t_2$  are to be of ordinary thicknesses used in the actual work.
3. Tack weld may be applied to the test assembly.
4. The fillet length is to be of ordinary length used in the actual work.

Fig 2.2.10 Test assembly for plates with fillet weld joint (unit : mm) (2023)

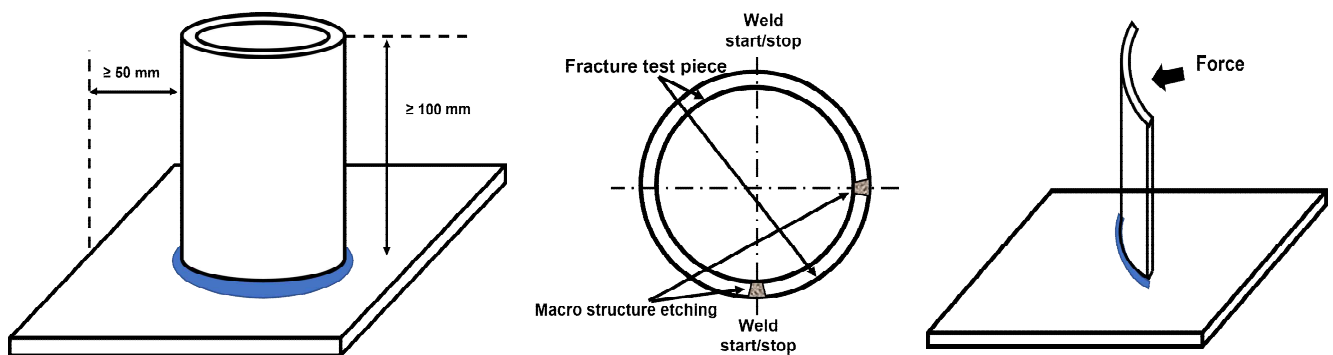


Fig 2.2.11 Test assembly for pipes with fillet weld joint (2023)

- (3) Test assembly is to be welded in the same welding positions as the actual work.
- (4) The assembly is to be welded on one side only, except in case deemed necessary by the surveyor.
- (5) For single run manual and semi-automatic welding, a stop/restart is to be included in the test length and its position is to be clearly marked for subsequent examination.

4. Visual & non-destructive inspection

- (1) Test assemblies are to be examined by visual and by non-destructive testing (PT or MT) prior to the cutting of test specimen. In case that any post-weld heat treatment is required or specified non-destructive testing and visual inspection are to be performed after heat treatment. (2019)
- (2) For weldable high strength steel with specified minimum yield strength of 420 N/mm<sup>2</sup> and above the non-destructive testing and visual inspection are to be delayed for a minimum of 48 hrs, unless heat treatment has been carried out. (2019)
- (3) NDT procedures are to be agreed with the Society. The results of visual & non-destructive testing are to show that there are no cracks or other injurious defects. (2019)
- (4) The imperfections detected by visual or non-destructive testing are to be assessed in accordance with ISO 5817, class B (ISO 10042:2018, class B for aluminium alloys), except for im-

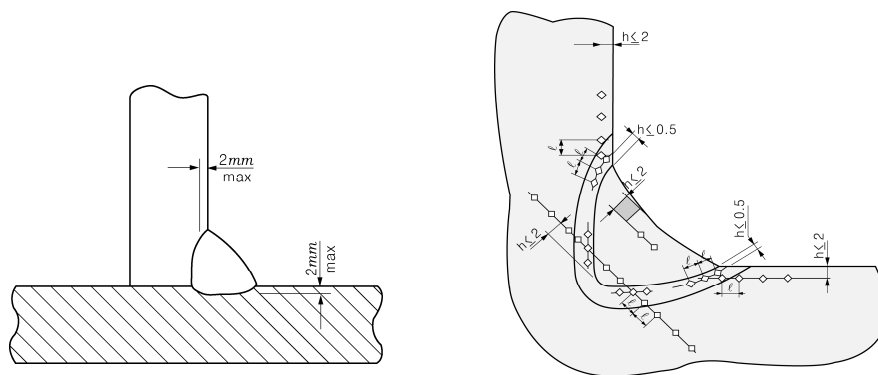
perfection type such as excessive convexity and excessive throat thickness for which level C applies (2019) (2022) (2023)

### 5. Macro-structure inspection

- (1) The test specimen is to be taken from the position in **Fig 2.2.10** and **Fig 2.2.11**. However, in case of rolled steels for hull structural, weldable high strength steel, and aluminium alloy, two specimens are to be taken. For manual welding and semi-automatic welding, one of the macro etched specimens is to be from the stop/restart position, if present.
- (2) The test specimens are to be prepared and etched on one side to clearly reveal the weld metal, fusion line, root penetration and the heat affected zone. Macro examination is to include about 10 mm unaffected base metal.
- (3) The examination is to reveal a regular weld profile, through fusion between adjacent layers of weld and base metal, sufficient root penetration and the absence of defects such as cracks, lack of fusion etc.

### 6. Hardness test (2019)

- (1) Hardness distribution at positions shown in **Fig 2.2.12** is to be measured.



Note

1. Measuring load is to be 10 kg vickers and measuring intervals are to be 1 mm.

**Fig 2.2.12 Hardness test for fillet welded joint (unit : mm) (2019)**

- (2) The results from the hardness test are to be in accordance with **Table 2.2.10**. (2019)

### 7. Fracture tests

The remaining test assemblies after the macro-structure test specimen has been removed are to be broken by pressing as shown in **Fig 2.2.8** and it shall be evaluated cracks, blow holes, poor penetrations and any other injurious defects in the fractured surface. And imperfections that are detected should be assessed in accordance with **(KS B) ISO 5817**, class B(**ISO 10042:2018**, class B for aluminium alloys). (2022) (2023)

## 406. Retests and Procedure qualification records(PQR)

### 1. Retests

- (1) Where visual inspection or non-destructive inspection fails to meet the requirements, the new test specimens welded under the same welding condition, are to be subject to retest and all of these test specimens are to pass the test. If this additional test piece does not comply with the relevant requirements, the pWPS is to be regarded as not capable of complying with the requirements without modification.
- (2) Where the result of a tensile or bend test does not comply with the requirements, twice as many test specimens as the number of specimens of failed test are to be selected from either the first test material or test materials welded under the same welding conditions, and all of these test specimens are to be satisfactorily tested.

- (3) If there is a single hardness value above the maximum values allowed, additional hardness tests are to be carried out (on the reverse of the specimen or after sufficient grinding of the tested surface). None of the additional hardness values is to exceed the maximum hardness values required.
- (4) (a) Where the result of the impact test is unsatisfactory, additional tests may be carried out, with the exception of the cases specified in (i) and (ii) below, by taking a set of test specimens out of the same test material from which the above-mentioned test specimens have been taken.
  - (i) The absorbed energy of all test specimens is under the required average absorbed energy.
  - (ii) The absorbed energy of two of the test specimens is under 70 % the required average absorbed energy.
- (b) In case of the previous (a), the test specimens may be accepted, provided that the average absorbed energy of the six test specimens, including those which have been rejected as unsatisfactory, is not less than the required average absorbed energy, and that not more than two individual results are lower than the required average absorbed energy and of these, not more than one result is below 70 % of the required average absorbed energy.
- (5) Where there is insufficient welded assembly remaining to provide additional test specimens, a further assembly is to be welded using the same procedure to provide the additional specimens.
- (6) Where the retest fails to meet the requirements, the test may be made over again. In this case, where the whole tests specified on the test assembly are carried out and are complied with requirements, the tests are accepted as successful.

## 2. Procedure qualification records(PQR)

- (1) Three copies of the procedure qualification records showing the welding conditions for test assemblies and test results are to be submitted to the Society for approval. Forms of welding procedure test records are to be at the discretion of the Society. **【See Guidance】**
- (2) A statement of the results of assessing each test piece, including repeat tests, is to be made for each welding procedure test. The relevant items listed for the WPS of these requirements are to be included.
- (3) A statement that the test piece was made according to the particular welding procedure is to be signed by the Surveyor witnessing the test and is to include the Society's identification.

## 407. Validity of qualified welding procedure specification

### 1. General

- (1) Welding procedures qualified at a manufacturer are valid for welding in workshops under the same technical and quality management.
- (2) Qualification of a welding procedure remains valid provided the welding variables are kept within the qualified range during production welding. When one or more variables outside the qualified range given in 2. occur, the welding procedure is to be respecified and requalified by welding procedure qualification tests.
- (3) Shop primers may have an influence on the quality of fillet welds and is to be considered. Welding procedure qualification with shop primer will qualify those without but not vice versa.

2. Validity of variables for qualified WPS is as follows. However, it may be considered as equivalent for the requirements of the standard internationally recognized(AWS, ASME etc.) are applied.

- (1) **Base metal** Kind of base metal and their validity are as follows. Other materials not specified herein is to be in accordance with the requirements of the standard internationally recognized as deemed appropriate by the Society. **【See Guidance】**

#### (a) Normal and higher strength hull structural steels

- ① Normal strength steel(A, B, D and E) or equivalent structural steels with tensile strength  $400 \sim 520 \text{ N/mm}^2$ .
- ② Higher strength steels, YP47 steels and brittle crack arrest steels(AH32, DH32, EH32, FH32, AH36, DH36, EH36, FH36, AH40, DH40, EH40, FH40, EH47-H, EH36-BCA1, EH40-BCA1/2 and EH47-H-BCA1/2) or equivalent structural steels with

- minimum specified yield strength 315 ~ 460 N/mm<sup>2</sup>. (2018) (2021)
- (i) For each strength level, welding procedures are considered applicable to the same and lower toughness grades as that tested.
  - (ii) For each toughness grade, welding procedures are considered applicable to the same and two lower strength levels as that tested.
  - (iii) For applying the above (i) and (ii) to high heat input processes above 50 kJ/cm, e.g. the two-run technique with either submerged arc or gas shielded metal arc welding, electro slag and electro gas welding, welding procedure is applicable to that toughness grade tested and one strength level below.
  - (iv) For *EH47-H*, welding procedure is applicable to that same and lower toughness grade tested and one strength level below. (*AH40*, *DH40* and *EH40*)
  - (v) Where Welding Procedure Specification (WPS) for the non-BCA steels has been approved by the Society, the said WPS is applicable to the same welding procedure applied to the same grade with suffix "BCA1" or "BCA2" except high heat input processes over 50 kJ/cm. (2021)
- (b) **Weldable high strength steels (Pt 2, Ch 1, 308. of the Rules)** or equivalent structural steels with minimum specified yield strength 365-960 N/mm<sup>2</sup>.
- (i) For each strength level, welding procedures are considered applicable to the same and lower toughness grades as that tested.
  - (ii) For each toughness grade, welding procedures are considered applicable to the same and one lower strength level as that tested.
  - (iii) For applying the above (i) and (ii) to high heat input processes above 50 kJ/cm, e.g. the two-run technique with either submerged arc or gas shielded metal arc welding, electro slag and electro gas welding, welding procedure is applicable to that toughness grade tested and one strength level below.
  - (iv) The approval of quenched and tempered steels does not quality thermo-mechanically rolled steels (TMCP steels) and vice versa. (2017) (2023)
- (c) **Weldable C and C-Mn hull steel castings**
- (i) Welding procedures are considered applicable to the same and lower strength level as that tested.
  - (ii) The approval of quenched and tempered hull steel castings does not quality other delivery conditions and vice versa.
- (d) **Weldable C and C-Mn hull and general purpose steel forgings**
- (i) Welding procedures are considered applicable to the same and lower strength level as that tested.
  - (ii) The approval of quenched and tempered hull steel forgings does not quality other delivery conditions and vice versa.
- (e) **Rolled steels for low temperature service and Steel pipes for low temperature service (2019)**
- (i) For carbon steels, welding procedures are considered applicable to the same and lower strength level as that tested, and the same and lower toughness grades as that tested.
  - (ii) For nickel alloy steels, welding procedures are considered applicable to the same and lower strength level as that tested, and the same and lower toughness grades as that tested.
- (f) **Rolled austenitic stainless steels and austenitic stainless steel pipes (2019)**  
Welding procedures are considered applicable to the equivalent and lower strength level as that tested, and the equivalent and lower level of alloying elements as that tested.
- (g) **Aluminium alloys (2019)**
- ① Group A: aluminium-magnesium alloys with *Mg* content = 3.5 % (alloy 5754)
  - ② Group B: aluminium-magnesium alloys with 4% = *Mg* = 5.6 % (alloys 5059, 5083, 5086, 5383 and 5456)
  - ③ Group C: aluminium-magnesium-silicon alloys (alloys 6005A, 6061 and 6082)
  - (i) For each Group, the qualification made on one alloy qualifies the procedure also for the other alloys of the same Group with equal or lower specified tensile strength after welding.
  - (ii) The qualification made on Group B alloy qualifies the procedure also for Group A alloys.
- (h) **Rolled steel plates for boiler (2019)**  
Welding procedures are considered applicable to the same and lower strength level as that tested.
- (i) **Rolled steel plates for pressure vessel (2019)**



- (i) Welding procedures are considered applicable to the same and lower strength level as that tested, and the same and lower toughness grades as that tested.
- (ii) The approval of quenched and tempered steels does not qualify other steels and vice versa.

(2) **Thickness and outer diameter of base metal**

- (a) The qualification of a WPS carried out on a plate or pipe test assembly of thickness  $t$  is valid for the thickness range given in **Table 2.2.13** and **Table 2.2.14**. (2019)

**Table 2.2.13 Qualified thickness range for butt, T-joint and fillet welds (2019)**

Thickness of test piece, $t$ (mm) <sup>(1)</sup>	Range of approval $t$ (mm) <sup>(2)</sup>	
	Butt and T-joint welds with single run or single run from both sides	Butt and T-joint welds with multi-run and fillet welds
$t \leq 3$	$0.7t \sim 1.1t$	$0.7t \sim 2t$
$3 < t \leq 12$	$0.7t \sim 1.1t$	$3 \sim 2t$
$12 < t \leq 100$	$0.7t \sim 1.1t$ <sup>(3)</sup>	$0.5t \sim 2t$ (max.150)
$100 < t$	$0.7t \sim 1.1t$ <sup>(3)</sup>	$0.5t \sim 2t$

Notes :

- (1) For multi process procedures, the recorded thickness contribution of each process is to be used as a basis for the range of approval for the individual welding process.
- (2) For the vertical-down welding, the test piece thickness "t" is always taken as the upper limit of the range of application.
- (3) For high heat input processes over 50 kJ/cm, the upper limit of range of approval is to be  $1.0 \times t$ .

**Table 2.2.14 Range of Aluminium alloys qualification for parent material thickness (2019)**

Thickness of the test piece $t$ (mm)	Range of approval
$t \leq 3$	$0.5t \sim 2t$
$3 < t \leq 20$	$3 \sim 2t$
$t > 20$	$\geq 0.8t$

- (b) The thickness  $t$  is defined for range of qualification as follows (2019)
  - (i) Butt welded joint  
The thickness  $t$  is based on the thinner material.
  - (ii) T-joint with full penetration weld  
The thickness  $t$  is based on the material with bevelling.
  - (iii) Fillet welded joint and T-joint with partial penetration weld  
The thickness  $t$  is based on the both base materials.
- (c) In addition to the requirements of **Table 2.2.13** and **Table 2.2.14**, the range of approval of throat thickness "a" for fillet welds is given in **Table 2.2.15**. (2019)

**Table 2.2.15 Range of qualifications for the throat thickness of fillet welds (2019)**

Kind( $a$ =throat thickness)		Range of approval(mm)
Base material other than Aluminium alloys	Single-run	$0.75a \sim 1.5a$
	Multi-run	as for butt welds with multi-run (i.e. $a=t$ )
Aluminium alloys <sup>(1)</sup>	$a < 10$	$0.75a \sim 1.5a$
	$a \geq 10$	$\geq 7.5$
Note (1) Where a fillet weld is qualified by means of a butt weld test, the throat thickness range qualified should be based on the thickness of the deposited weld metal.		

- (d) The qualification of a WPS carried out on a pipe test assembly is valid for the outer diameter range given in **Table 2.2.16**.

**Table 2.2.16 Qualified outer diameter range for pipe welds (2019)**

Outer diameter $D$ (mm)	Qualified range (mm) <sup>(1)</sup>
$D \leq 25$	$0.5 D \sim 2 D$
$D > 25$	$\geq 0.5 D$ (min. 25)
Note (1) When the test for plate is approved, the welding for the pipes over 500 mm in outer diameter is permitted.	

- (e) Notwithstanding the above, the approval of maximum thickness of base metal for any technique is to be restricted to the thickness of test assembly if three of the hardness values in the heat affected zone are found to be within 25 Hv of the maximum permitted, as stated **404. 10** (2) and **405. 7** of the Rules.

**(3) Welding positions**

- (a) Approval for a test made in any position is restricted to that position (see **Table 2.2.23-2** and **Table 2.2.23-3** of the Rules). Approval range for aluminium alloys is given in **Table 2.2.17** (2019)

**Table 2.2.17 Range of qualifications for aluminium alloys's welding position (2019)**

Test Position	Welding positions in actual welding position
PA(flat)	PA
PC(horizontal)	PA, PC
PE(overhead)	PA, PC, PE
PF(vertical-up)	PA, PC, PF
NOTES: (1) A qualification position performed on a butt weld will also qualify for fillet welding within the thickness ranges specified for fillet welds specified in (2) (a) above but not vice versa.	

- (b) To qualify a range of positions, test assemblies are to be welded for highest heat input position and lowest heat input position and all applicable tests are to be made on those

assemblies. For plates butt welds with full penetration, the highest heat input position is normally the vertical upwards position and the lowest heat input position is normally the horizontal position. And for pipes butt welds with full penetration, all positions for pipes are permitted by the qualified welding procedure with PH-45(inclined upwards). But PG(vertical-down), PJ(downwards) and PJ-45(inclined downwards) are required separate qualification testing and only be acceptable for that position. (2019)

- (c) Fillet weld joints, T-joints with full penetration and T-joints with partial penetration are permitted by the approval of butt welding in accordance with **Table 2.2.18**. (2019)

**Table 2.2.18 Correlation with Fillet joints, T-joints(with full penetration and partial penetration) welding and butt welding (2019)**

Approved position for butt welding	Actual welding position for fillet joints, T-joints with full penetration & partial penetration
PA(flat)	PA(flat), PB(horizontal vertical)
PC(horizontal)	PB(horizontal vertical), PC(horizontal)
PE(overhead)	PD(horizontal overhead), PE(overhead)
PF(vertical-up)	PF(vertical-up)
PG(vertical-down)	PG(vertical-down)

**(4) Welding process**

- (a) The approval is only valid for the welding process(es) used in the welding procedure test. It is not permitted to change from a multi-run to a single run.
- (b) For multi-process procedures the welding procedure approval may be carried out with separate welding procedure tests for each welding process. It is also possible to make the welding procedure test as a multi-process procedure test. The approval of such a test is only valid for the process sequence carried out during the multi-process procedure test.

**(5) Welding consumables**

- (a) Welding consumables cover other approved welding consumables having the same grade mark including all suffixes specified in **Pt 2, Ch 2, Sec 6** of the Rules with the welding consumable tested. For WPQT has high heat input processes over 50 kJ/cm, no change in the grade mark or brand name of the consumables is permitted. For welding procedure over hull structural and weldable construction, the approval range of welding consumables is left to the discretion of the Society. (2017) (2019)
- (b) Change in welding consumables specified in **Table 2.2.3**(Application of welding consumables) of **Pt 2, Ch 2** of the Rules is only permitted. (2017)
- (c) Change in shielding gas in accordance with **Pt 2, Ch 2, 603. 3 (4)** of the Rules is only permitted. (2017)

**(6) Welding condition**

- (a) Changes in the type of current (*AC, DC, pulsed*) and polarity require a new welding procedure qualification. (2019)
- (b) The lower limit of approval is the preheat temperature applied at the start of the welding procedure test. The upper limit of approval is the interpass temperature reached in the welding procedure test. (2019)
- (c) The heat treatment used in the qualification test is to be maintained during manufacture. Holding time may be adjusted as a function of thickness. Addition or deletion of post weld heat treatment or ageing is not permitted except that artificial ageing for 6000 series alloys gives approval for prolonged natural ageing. (2019)

**(7) Heat input**

- (a) The upper limit of heat input approved is 25 % greater than that used in welding the test piece or 55 kJ/cm whichever is smaller, except that the upper limit is 10 % greater than that for high heat input processes over 50 kJ/cm.

- (b) The lower limit of heat input approved is 25 % lower than that used in welding the test piece.
- (8) **Type of joint**
- (a) Range of approval depending on type of welded joints for test assembly is to be specified in **Table 2.2.19**.
- (b) A qualification test performed on a butt weld will also qualify for fillet welding, T-joints with full/partial penetration within the thickness ranges specified for fillet welds specified in (2) (a) above. (2019)

**Table 2.2.19 Range of approval for type of welded joint (2019)**

Type of welded joint for test assembly				Range of approval
Butt welding	One side	With backing	A	A, C
		Without backing	B	A, B, C, D
	Both side	With gouging	C	C
		Without gouging	D	C, D <sup>(1)</sup>
NOTES:				
(1) For aluminium alloys, range of approval includes "A"				

- (c) Change of specified type of joint which may significantly affect penetration and fusion etc, of the weld. However decrease in the groove angle, decrease in the root opening or increase in root face is to be as deemed appropriate by the Society. **【See Guidance】**
- (9) **Others** The Validity relating to the welding variables other than previous (1) to (8) may comply with the requirements of the internationally recognized Code (*AWS, ASME, ISO, EN* etc.)
3. For changes other than previous 2, the welding procedure qualification test may be dispensed with. In this case, the welding procedure specification to which the related procedure qualification record(PQR) is attached is to be requalified.

## Section 5 Welders and Welder Performance Qualification Scheme (2018)

### 501. General

1. Each welder intended to engage in the welding work for shipbuilding and repair is to pass the performance qualification tests required according to the applicable welding process, welding position and kinds of materials to be welded and to have the performance qualification by the Society.
2. Welders engaged in tack welding are to pass the performance qualification tests and should be qualified for tack welds in accordance with the requirements in this Section. A welder qualified for butt or fillet welding can be engaged in tack welding for the welding process and position corresponding to those permitted in his certificate.
3. Welding operators responsible for setting up and/or adjustment of fully mechanized and automatic equipment, such as submerged arc welding, gravity welding, electro-gas welding and MAG welding with auto-carriage, etc., must be qualified whether they operate the equipment or not. However a welding operator, who solely operates the equipment without responsibility for setting up and/or adjustment, does not need qualification provided that he has experience of the specific welding work concerned and the production welds made by the operators are of the required quality.
4. The performance qualification test of welder intended to engage in the special material and welding work not prescribed in this Section are to be at the discretion of the Society.
5. The training of welders, control of their qualification and maintenance of their skills are the responsibility of shipyards and manufacturers. The Surveyor is to verify and be satisfied that the welders are appropriately qualified.
6. Welders or welding operators qualified in accordance with national or international welder qualification standards may also be engaged in welding of hull structures at the discretion of the Society provided that standard is considered equivalent to this Section from technical perspective covering examination, testing and range approval. Even if the requirements stipulated in the standards are applied, the requirement for revalidation of welders' qualification shall be in accordance with **504. 2.** And alternative welding standards or codes are to be applied in full, cross-mixing requirements of standards and codes is not permitted. (2022)

### 502. Grades, and range of qualification

1. A welder should be qualified in relation to the variables such as base material, welding process, welding consumables type, type of welded joint, plate thickness and welding position.
2. **Welding processes**
  - (1) The welding processes for welder's qualification are to be classified in **Table 2.2.20.**

**Table 2.2.20 Welding processes for welder's qualification (2019) (2022)**

Symbol	Welding process in actual welding works <sup>(1)(2)</sup>		ISO 4063:2009
M	Manual welding	Shield Metal Arc Welding(SMAW)	111
G	Gas welding	Gas Welding(GW)	31
S	Semi-automatic welding	(1) Metal Inert Gas welding(MIG)	131
		(2) Metal Active Gas welding(MAG)	135(solid wire), 138(metal cored wire)
		(3) Flux Cored Arc Welding(FCAW)	136
T	TIG welding	Gas Tungsten Arc Welding(GTAW)	141
A	Automatic welding	(1) Submerged Arc Welding(SAW)	12
		(2) Gravity Welding(GRW)	112
		(3) Electro-gas Welding(EGW)	73
		(4) Electro-slag Welding(ESW)	72
<p>NOTES:</p> <p>(1) Each testing normally qualifies only for one welding process. A change of welding process requires a new qualification test. Welders who have passed qualification tests for semi-automatic welding or TIG welding may be similarly regard as the welder responsible for setting up and/or adjusting of the welding process using an auto-carriage in the range of qualification for the qualification they qualified.</p> <p>(2) It is permitted for a welder to be qualified for two or more welding processes by welding a single test piece with multi-process joint and sequence or by two or more separate qualification tests. The sequence of welding processes can not be changed.</p>			

### 3. Welding consumables

- (1) The welding consumable covers qualification of the welder or welding operator for the welding of all other consumables within base material group classified as specified in 5.
- (2) For manual welding, qualification tests are required using basic, acid or rutile covered electrodes.
- (3) Welding with filler material qualifies for welding without filler material, but not vice versa.

### 4. Types of welded joint

- (1) The types of welded joint for welder's qualification are to be classified as shown in **Table 2.2.21** in accordance with the qualification test.
- (2) Welders engaged in full/partial penetration T welds are to be qualified for butt welds for the welding process and the position corresponding to the joints to be welded.
- (3) Tack welders engaged in butt welds are to be qualified for fillet welds for the welding process and the position corresponding to the joints to be welded but not vice versa. (2019)

**Table 2.2.21 Types of welded joint for welder's qualification**

Type of welded joint used in the test assembly for the qualification test				Type of welded joint qualified
Butt weld	Single Sided weld	with Material Backing	SS MB	SS MB, DS MB, SL, ML
		with Gas Backing	SS GB	SS MB, SS GB, DS MB, SL, ML
		with No Backing	SS NB	SS MB, SS NB, SS GB, DS MB, DS NB, SL, ML
	Double Sided weld	with gouging	DS MB	SS MB, DS MB, SL, ML
		without gouging	DS NB	SS MB, DS MB, DS NB, SL, ML
Fillet weld	Single Layer weld	–	SL	SL
	Multi-Layer weld	–	ML	SL, ML

### 5. Base materials

(1) Base materials for qualification tests are grouped in **Table 2.2.22**.

Table 2.2.22 Base material group for welder's qualification

Base material group used in the test assembly for the qualification test <sup>(1)</sup>			Qualified group <sup>(1)(2)</sup>	
Carbon steels <sup>(1)</sup>	Rolled steels for hull structural Rolled steel plates for boiler Rolled steel plates for pressure vessel Rolled steels for low temperature service (except nickel alloy) Round bars for chain Rolled steel bars for boiler High strength steels for welded structures YP47 steel plates Steel tubes for boilers and heat exchangers Steel pipes for pressure piping Steel pipes for low temperature service (except nickel alloy) Carbon steel castings Low alloy steel castings Steel castings for chains Steel castings for low temperature service (except <i>RLC2</i> and <i>RLC3</i> ) Carbon steel forgings Alloy steel forgings Steel forgings for chains Steel forgings for low temperature service (except <i>RLF3</i> and <i>RLF9</i> )	<i>A ~ FH40</i> <i>RSP42 ~ RSP49A</i> <i>RPV24 ~ RPV50</i> <i>RL 235A ~ RL 355</i>  <i>RSBC31 ~ RSBC70</i> <i>RSB 42 ~ RSB 46</i> <i>AH43 ~ FH70</i> <i>EHA7-H</i> <i>RSTH 12 ~ RSTH52</i> <i>RST138 ~ RST424</i> <i>RLPA ~ RLPC</i>  <i>RSC410 ~ RSC600</i> <i>RSC440A ~ RSC550A</i> <i>RSCC50, RSCC70</i> <i>RLCA, RLCB</i>  <i>RSF400 ~ RSF760(H/M)</i> <i>RSF550AM ~ RSF1100AM</i> <i>RSFC50, RSFC 70</i> <i>RLFA ~ RLFC</i>	CS	CS
Stainless steels	Rolled stainless steels Stainless steel pipes Stainless steel castings Stainless steel casting for propeller Stainless steel forgings Duplex stainless steel	<i>RSTS304 ~ RSTS347</i> <i>RSTS304TP ~ RSTS347TP</i> <i>RSSC13 ~ RSSC21</i> <i>12Cr1Ni, 19Cr11Ni</i> <i>RSSF304 ~ RSSF347</i> <i>S31803, S32750</i>	STS	STS
Nickel alloy	Rolled steels for low temperature service (except carbon steels) Steel pipes for low temperature service (except carbon steels) Steel castings for low temperature service (except <i>RLCA</i> and <i>RLCB</i> ) Steel forgings for low temperature service (except <i>RLFA ~ RLFC</i> )	<i>RL 1N355 ~ RL 9N490</i>  <i>RLP2 ~ RLP9</i>  <i>RLC2, RLC3</i>  <i>RLF3, RLF9</i>	NI	NI
Copper and copper alloy	Copper and copper alloy pipes and tubes Copper alloy castings	<i>C 1201 ~ C7150</i> <i>CU1 ~ CU4</i>	CU	CU
Aluminium alloys	Aluminium alloys	<i>5083 ~ 6082 (P/S)</i>	AL	AL
NOTES : (1) Base materials for qualification of welders or welding operators are combined into one group with a specified minimum yield strength $R_{eH} \leq 460 \text{ N/mm}^2$ for hull structures. (2) For welding with materials in different material groups, qualification approval may be carried out with separate qualification test for each material.				



## 6. Thickness and outer diameter of base metal

- (1) The welder qualification carried out on a plate or pipe test assembly of thickness  $T$  is valid for the thickness range given in **Table 2.2.22-1**. The qualified thickness range for tack welders is 3 mm and over. (2019)

**Table 2.2.22-1 Qualified thickness range for welder qualification (2020)**

Grades	Thickness of test assembly, $T$ (mm)	Qualified thickness range, $t$ (mm)
Butt/fillet weld of plate, Butt weld of pipe	$T < 3$	$T \leq t \leq 2T$
	$3 \leq T < 12$	$3 \leq t \leq 2T$
	$12 \leq T$	$3 \leq t$
Fillet weld of pipe	$T < 3$	$T \leq t \leq \text{Larger}(2T \text{ or } 3\text{mm})$
	$3 \leq T$	$3 \leq t$

- (2) The welder qualification carried out on a pipe test assembly is valid for the outer diameter range given in **Table 2.2.22-2**.

**Table 2.2.22-2 Qualified outer diameter range for pipe welds**

Outer diameter $D$ (mm) of the test piece <sup>(1)(2)</sup>	Qualified range $d$ (mm)
$D \leq 25$	$D \leq d \leq 2D$
$25 < D$	$0.5D \leq d$ (Min. 25 mm)

NOTES :

(1) Test assemblies for the pipes with 500 mm and over in diameter may be those for the plates. However, test assemblies for tack welding of the pipes may be those for the plates regardless of the outer diameter of the pipe. (2022)

(2) For non-circular hollow sections,  $D$  is the dimension of the smaller side.

## 7. Positions

The positions for qualification test and positions qualified for actual welding work are to comply with the **Table 2.2.23-1**.

Table 2.2.23-1 Welding Positions for Welder Qualification

Test Positions <sup>(1)(2)</sup>			Welding positions in actual welding work <sup>(1)(2)</sup>																							
			Plates <sup>(3)</sup>								Pipes <sup>(4)</sup>															
			Butt joint				Fillet joint				Butt joint				Fillet joint											
			PA	PC	PE	PF	PG	PA	PB	PC	PD	PE	PF	PG	PA	PC	PH	PJ	PH-45	PJ-45	PA	PB	PD	PH	PJ	PH-45
Plates	Butt joint	Flat	PA	●						●	●								●	●						
		Horizontal	PC	●	●						●	●	●							●	●					
		Overhead	PE	●	●	●					●	●	●	●	●					●	●	●				
		Vertical-up	PF	●			●					●								●	●					
		Vertical-down	PG																							
	Fillet joint	Flat	PA								●									●						
		Horizontal vertical	PB								●	●								●	●					
		Horizontal	PC								●	●	●							●	●					
		Horizontal overhead	PD								●	●	●	●	●					●	●	●				
		Overhead	PE								●	●	●	●	●					●	●	●				
		Vertical-up	PF								●	●				●				●	●					
		Vertical-down	PG																							
	pipes	Butt joint	Flat	PA	●						●	●								●	●					
			Horizontal	PC	●	●						●	●	●							●	●				
Upwards			PH	●		●	●				●	●		●	●	●				●	●	●	●			
Downwards			PJ	●		●		●			●	●		●	●		●			●	●	●		●		
Inclined upwards			PH-45	●	●	●	●				●	●	●	●	●	●				●	●	●	●		●	
Inclined downwards			PJ-45	●	●	●		●			●	●	●	●	●	●				●	●	●		●		●
Fillet joint		Flat	PA								●									●						
		Horizontal vertical	PB								●	●								●	●					
		horizontal overhead	PD								●	●	●	●	●					●	●	●				
		Upwards	PH								●	●		●	●	●				●	●	●	●			
		Downwards	PJ								●	●		●	●		●			●	●	●		●		
		Inclined upwards	PH-45								●	●	●	●	●	●				●	●	●	●		●	
		Inclined downwards	PJ-45								●	●	●	●	●	●				●	●	●		●		●

NOTES:

- (1) ● indicates those welding positions for which the welder is qualified.
- (2) Test positions are to comply with **Table 2.2.23-2** and **Table 2.2.23-3**.
- (3) The welders or welder operators only qualified for pipe over 25 mm in outer diameter are permitted the welding for plates.
- (4) The welders or welder operators qualified for plates are only permitted the welding for pipe over 500 mm in outer diameter. However, the tack welders qualified for plates are permitted the tack welding for pipes regardless of the outer diameter of the pipe. (2022)

Table 2.2.23-2 Welding position of plates


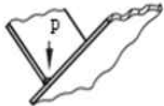
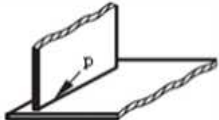
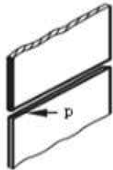
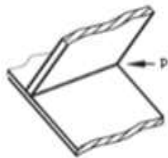
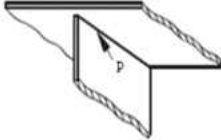
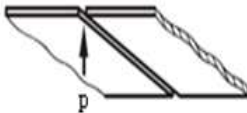
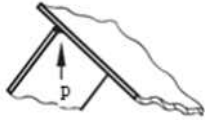
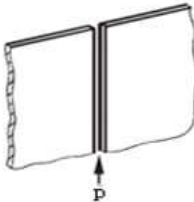



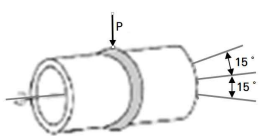

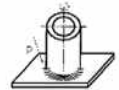
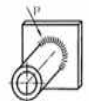
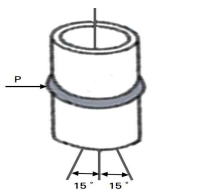
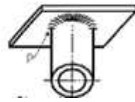
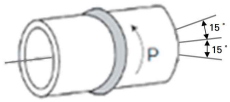
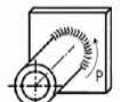
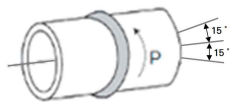

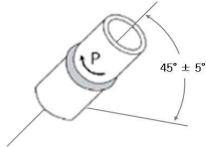

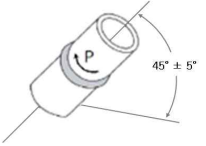

Welding position		Description of welding position	
		Butt welds	Fillet welds
Flat	PA		
Horizontal vertical	PB	-	
Horizontal	PC		
Horizontal overhead	PD	-	
Overhead	PE		
Vertical up	PF		
Vertical down	PG		
Upwards	PH	-	-
Downwards	PJ	-	-
Inclined upwards	PH-45	-	-
Inclined downwards	PJ-45	-	-

Table 2.2.23-3 Welding position of pipes

Welding position		Description of welding position	
		Butt welds	Fillet welds
Flat	PA	 <p>pipe rotating</p>	 <p>pipe rotating</p>
Horizontal vertical	PB	-	 <p>pipe fixed or rotating</p>  <p>pipe rotating</p>
Horizontal	PC	 <p>pipe fixed or rotating</p>	-
Horizontal overhead	PD	-	 <p>pipe fixed or rotating</p>
Overhead	PE	-	-
Vertical up	PF	-	-
Vertical down	PG	-	-
Upwards	PH	 <p>pipe fixed</p>	 <p>pipe fixed</p>
Downwards	PJ	 <p>pipe fixed</p>	 <p>pipe fixed</p>
Inclined upwards	PH-45	 <p>pipe fixed</p>	 <p>pipe fixed</p>
Inclined downwards	PJ-45	 <p>pipe fixed</p>	 <p>pipe fixed</p>

### 503. Testing procedure

#### 1. General

- (1) The test assemblies are not to be changed their up-and-down or right-and-left position throughout the welding operation.
- (2) The test assemblies are not to be subjected to peening or heat treatment throughout the period before, during and after the welding.
- (3) The backing strips of the test assemblies may be used steel plates, copper plate, ceramic, similar materials to obtain the enough penetration or backing gas used for WPS or pWPS.
- (4) Welding of the test assemblies and testing of test specimens should be witnessed by the Surveyor.

#### 2. Test assemblies

- (1) Test assemblies for butt welds and for fillet welds are to be prepared as shown in **Fig 2.2.13** to **Fig 2.2.20** in each qualification test.
- (2) Materials used for tests are to be those specified in **502. 5** or those which are considered equivalent by the Society.

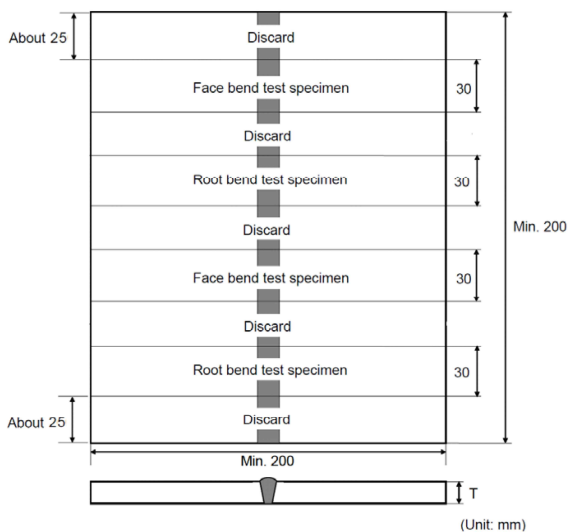


Fig 2.2.13 Dimensions and types of test assembly for butt welds (2023)

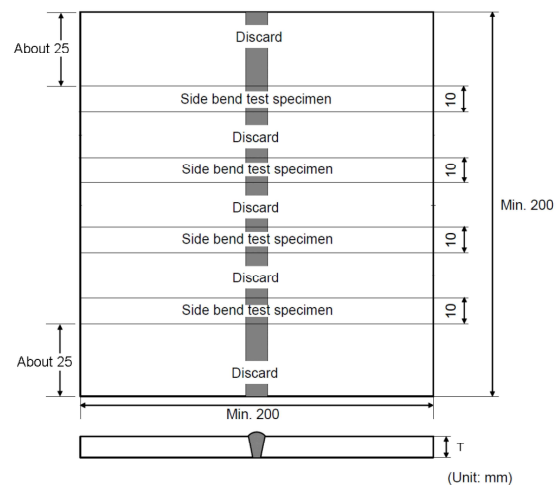


Fig 2.2.14 Dimensions and types of test assembly for butt welds ( $T \geq 12\text{mm}$ )

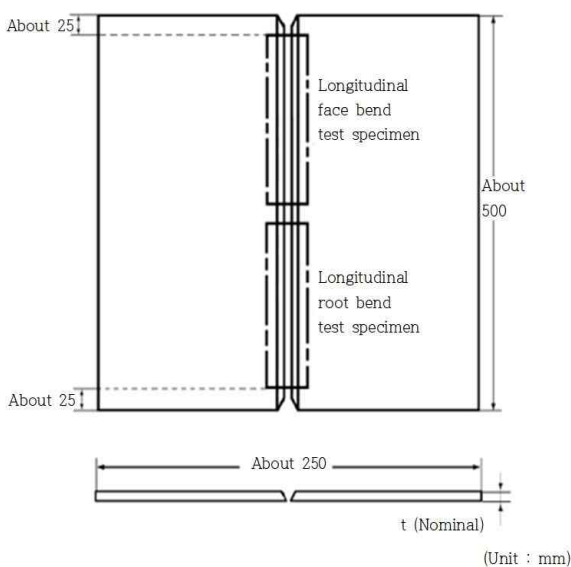


Fig 2.2.15 Dimensions and types of test assembly for butt welds (For 9%nickel alloys)

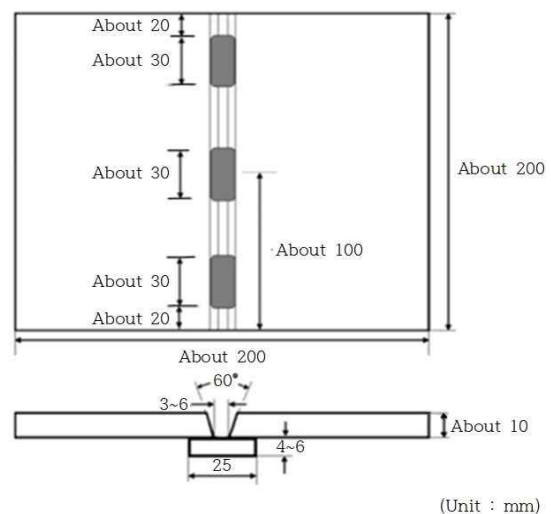


Fig 2.2.16 Dimensions and types of test assembly for tack butt welds

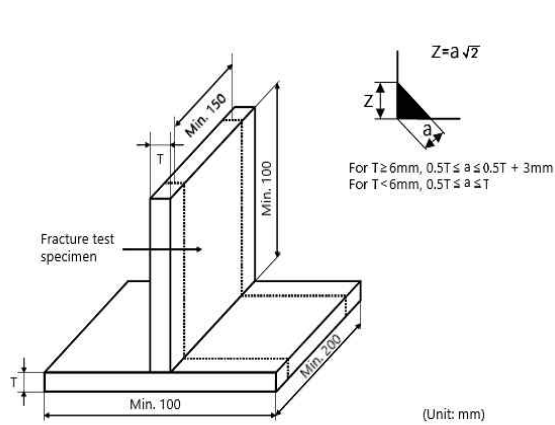


Fig 2.2.17 Dimensions and types of test assembly for fillet welds

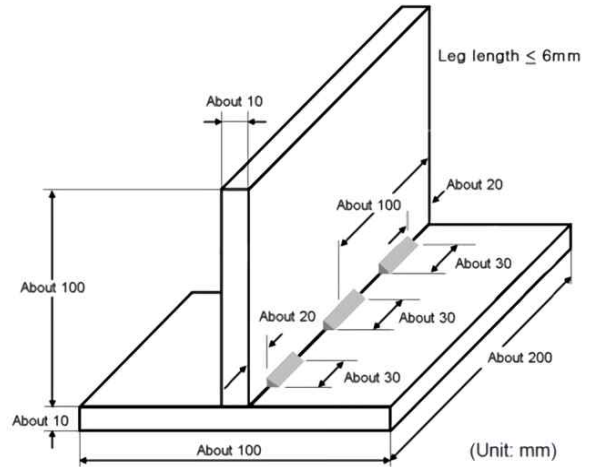


Fig 2.2.18 Dimensions and types of test assembly for tack fillet welds

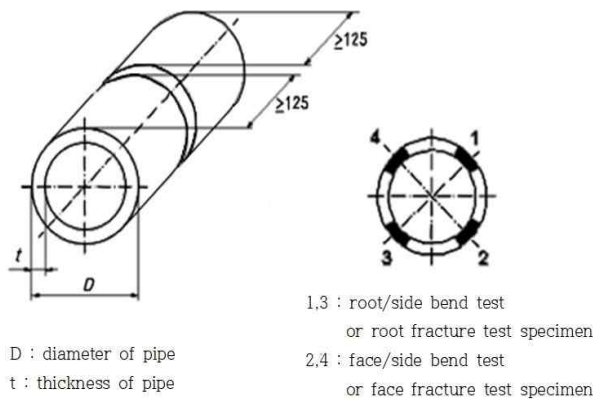


Fig 2.2.19 Dimensions and types of test assembly for pipe butt welds

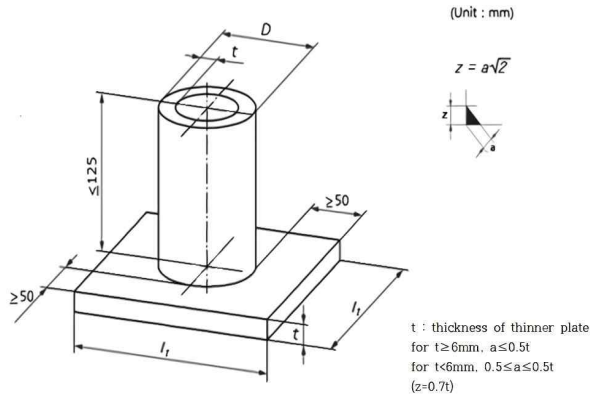


Fig 2.2.20 Dimensions and types of test assembly for pipe fillet welds

- (3) The dimensions and types of welded joint are to be in accordance with WPS or pWPS.
- (4) Welding consumables used in qualification tests should be type approved one or those which are considered equivalent by the Society.
- (5) For other than fully mechanized and automatic welding, root run and capping run need each to have a minimum of one stop and restart. The welders are allowed to remove minor imperfections only in the stop by grinding before restart welding. (2019)
- (6) Test assembly for automatic welding is to comply with 404. 3 and 405. 3. For butt welded joints, the width of test assembly is not to be less than 300 mm and the length not to be less than 400 mm. For fillet welded joints, the width of test assembly is not to be less than 150 mm and the length not to be less than 400 mm.
- (7) Test assemblies used in the qualification test of gas welding are to be of without backing, and gas welding rods are to be those for mild steel complying with a KS D7005 (Gas welding rods for mild steel) or EN 12536 or those considered appropriate by the Society.

### 3. Examination and test

- (1) Examination and test are as specified in Table 2.2.24.

**Table 2.2.24 Examination and test for Welder Qualification (2022)**

Kinds	Examination and test <sup>(6)</sup>
Butt welds	Visual inspection, Bend test <sup>(1)(2)(3)(4)</sup>
Fillet welds	Visual inspection, Fracture test <sup>(5)</sup>
Tack welds	Visual inspection, Fracture test

NOTES

(1) Radiographic test or fracture test may be carried out in lieu of bend test except the welding processes in the **Table** below.

Material	Welding process(see <b>Table 2.2.20</b> )
Carbon steels, Stainless steels	131, 135, 138, 311(Oxyacetylene welding)
Nickel alloys	131, 135
Aluminium alloys	131
Copper and copper alloy	All welding processes

And the radiographic test may be replaced by ultrasonic test for thickness 8 mm or above on ferritic steels(e.g. carbon steel, etc.) only.

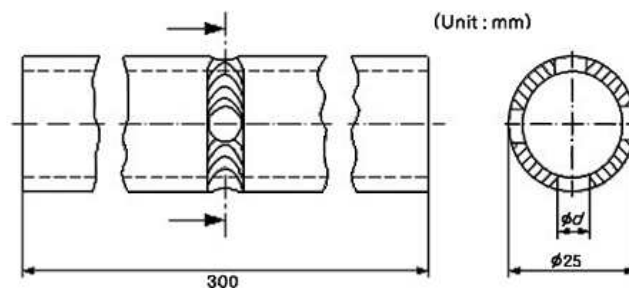
(2) For 9%nickel alloy in plates, longitudinal bend test specimens may be used as shown in **Fig 2.2.11**.

(3) For nickel alloy in tubes, radiographic tests or fracture test mayh be carried out in lieu of bend test notwithstanding (1) above.

(4) For pipe with outer diameters  $D \leq 25$  mm, the bend or fracture tests may be replaced by a notched tensile test of the complete test assemblies as shown in **Fig 2.2.21**.

(5) Two macro sections may be taken in lieu of the fracture test.

(6) Additional tests may be required, at the discretion of the Society. **[See Guidance]**



(Note)

1. The size of is as follows:

(1)  $t \geq 1.8\text{mm}$  :  $d = 4.5\text{mm}$

(2)  $t < 1.8\text{mm}$  :  $d = 3.5\text{mm}$

$d$ : diameter of the hole in weld

(Holes are not allowed in start and stop areas)

2. Notch profiles  $s$  and  $q$  are also permitted in circumferential direction according to *ISO 9017*

**Fig 2.2.21 Notch tensile test for pipe assemblies outer diameter  $D \leq 25$  mm**

**(2) Visual examination**

(a) The welds should be visually examined prior to the cutting of the test specimen for the bend test.

(b) The result of the examination is to show the absence of cracks or other serious imperfections. Imperfections detected are to be assessed in accordance with quality level B in **(KS B) ISO 5817:2014(ISO 10042:2018**, class B for aluminium alloys), except for im-



perfection type such as excess weld metal, excess penetration, excessive convexity and excessive throat thickness for which level C applies. (2022) (2023)

(3) **Bend test**

- (a) Two face bend test and two root bend test specimens are to be tested for initial qualification test. For thickness 12 mm and over, four side specimens with 10 mm in thickness may be tested as an alternative.
- (b) One face and one root bend test specimens for maintenance of approval. For thickness 12 mm and over, two side specimens with 10 mm in thickness may be tested as an alternative.
- (c) At least one bend test specimen is to be included one stop and restart in the bending part, for root run or for cap run.
- (d) Bend test specimens are to be of size and dimensions given in **Table 2.2.2** according to the kind of test assemblies.
- (e) The mandrel diameter to thickness ratio (i.e. D/t) is to be that specified in each article of **Pt 2, Ch 2, Sec 6** of the Rules +1 except for aluminium alloy for which requirements in **Table 2.2.65** of **Pt 2, Ch 2, 608** of the Rules applies.
- (f) The test specimens are to be bent through 180 degrees. After the test, the test specimens should not reveal any open defects in any direction greater than 3mm. Defects appearing at the corners of a test specimen during testing should be investigated case by case.  
**[See Guidance]**
- (g) For roller bend test of gas welding, the radii of the plunger of the jig and support roller are to be 10 mm, and the roller spans to be 53 mm.

(4) **Non-destructive testing**

- (a) When radiographic testing or ultrasonic testing is used in lieu of bend test, imperfections detected are to be assessed in accordance with **(KS B) ISO 5817:2014**, level B(**ISO 10042:2018**, class B for aluminium alloys). (2022) (2023)
- (b) Where deemed the excess of the amount of heat input by visual inspection after welding, bend tests other than radiographic testing may be required additionally.

(5) **Fracture test**

- (a) When fracture test is used for butt welds, full test specimen in length is to be tested in accordance with **ISO 9017:2017** and **ISO 9606-1:2012, 9606-2/3/4**. Imperfections detected are to be assessed in accordance with **(KS B) ISO 5817:2014**, level B(**ISO 10042:2018**, class B for aluminium alloys). (2022) (2023)
- (b) The fracture test of fillet welds is to be carried out in accordance with the requirements specified in **Pt 2, Ch 2, 405. 8** of the Rules. Evaluation should concentrate on cracks, porosity and pores, inclusions, lack of fusion and incomplete penetration. Imperfections that are detected should be assessed in accordance with **(KS B) ISO 5817:2014**, level B(**ISO 10042:2018**, class B for aluminium alloys). (2022)

(6) **Macro examination**

When macro examination is used for fillet welds, examination procedures and acceptance criteria are to be as follows;

- (a) Two test specimens are to be prepared from different cutting positions; at least one macro examination specimen is to be cut at the position of one stop and restart in either root run or cap run.
- (b) The test specimens are to be prepared and etched on one side to clearly reveal the weld metal, fusion line, root penetration and the heat affected zone.
- (c) Macro sections should include about 10mm of unaffected base metal.
- (d) The examination is to reveal a regular weld profile, through fusion between adjacent layers of weld and base metal, sufficient root penetration and the absence of defects such as cracks, lack of fusion etc.

**4. Retest**

- (1) When a welder fails a qualification test, the following should apply.
  - (a) In cases where the welder fails to meet the requirements in part of the tests, a retest may be welded immediately, consisting of another test assembly of each type of welded joint and position that the welder failed. In this case, the test is to be done for duplicate test specimens of each failed test. All retest specimens are fully comply with all of the specified requirements.
  - (b) In cases where the welder fails to meet the requirements in all parts of the required tests or in the retest prescribed in (a) above, the welder should undertake further training and practice.

- (c) When there is specific reason to question the welder's ability or the period of effectiveness has lapsed, the welder is to be re-qualified, not retested.
- (2) Where any test specimen does not comply with dimensional specifications due to poor machining, a replacement test assembly should be welded and tested.

#### 5. Certification

- (1) Qualification certificates are normally issued to shipbuilder or manufacturer when the welder has passed the qualification test in accordance with the Society's Rules. Each Shipyard and Manufacturer is to be responsible for the control of the validity of the certificate and the range of the approval. (2022)
- (2) The following items should be specified in the certificate:
  - (a) Range of qualification for materials, welding processes, filler metal type, types of welded joint, plate thicknesses and welding positions;
  - (b) Expiry date of the validity of the qualification;
  - (c) Name, date of birth, identification and the photograph of the welder;
  - (d) Name of shipbuilder / manufacturer.
- (3) When a certificate is issued, the relative documents such as test reports and/or re-validation records are to be archived as annexes to the copy of certificate.

### 504. General requirements for qualification validity

#### 1. Initial approval

- (1) Normally the validity of the welder's approval begins from the issue date of qualification certificate when all the required tests are satisfactorily completed.
- (2) Where welder has not engaged in a particular process and equipment for a period exceeding six months, his qualification is automatically withdrawn. All the following conditions are fulfilled for maintaining welder's qualification. If any of these conditions are not fulfilled, the Society is to be informed and the certificate is to be cancelled.
  - (a) The welder should be engaged with reasonable continuity on welding work within the current range of approval. The welder's work should in general be in accordance with the technical conditions under which the approval test is carried out.
  - (b) The qualification validity of welder is to be confirmed at six-month intervals by the shipyards/manufacturers responsible for weld quality. After this confirmation, the certificate is to be signed by the shipyards/manufacturers.
  - (c) The status of approvals of each individual qualification is to be demonstrated to the Society when requested.
  - (d) There shall be no specific reason to question the welder's skill and knowledge.
- (3) Where welder has failed to meet the requirements of the Society in welding work as follows, his qualification is to be suspended.
  - (a) When welder quits his job from the company where he had employed and certified.
  - (b) Where there is some specific reason to question a qualified welder's ability.
- (4) The effectiveness of qualification of welder who has switched his job specified in (3) (a) above may be considered as remaining, provided that the all followings are satisfied. For remaining, the certificate may be issued to last shipyards/manufacturers.
  - (a) It is to be proved that the welders have kept performance qualification at previous company.
  - (b) It is to be proved that welding condition is similar to those of previous company, and the welders carried out qualified work with acceptance welding performance.
  - (c) It is to be proved that welders had worked with a particular process and equipment for a period exceeding six months before quitting.

#### 2. Maintenance of the approval

- (1) Revalidation is to be carried out by the Society. The skill of the welder is to be periodically verified by one of the following (A) ~ (C) options. The chosen maintenance option scheme of qualification is in accordance with (A) or (B) or (C) shall be stated on the certificate at the time of issue: (2022)
  - (A) The welder is to be re-tested every 3 years. The welder is to be performed the test for re-validation within 6 months before the expiration date of qualification. These tests revalidate the welder's qualifications for an additional 3 years. (2022)
  - (B) Every 2 years, two welds made during the last 6 months of the 2 years validity period are

- to be tested by radiographic or ultrasonic testing or destructive testing and shall be recorded. The weld tested shall reproduce the initial test conditions except for the thickness and the outer diameter. These tests revalidate the welder's qualifications for an additional 2 years.
- (C) A welder's qualification for any certificate shall be valid as long as it is signed according to 1. (2) above subject that all the following conditions are fulfilled. In this option, the fulfilment of all the conditions is to be verified by the Society. The frequency of verification by the Society is to be no longer than 3 years and is to be agreed between the Society and the shipyards/manufacturers. This can be replaced by a method recognized by the Society. (2020) (2022) [See Guidance]
- (a) The welder is working for the same shipyard/manufacturer which is responsible for production weld quality as indicated on his or her qualification certificate.
  - (b) The Society shall verify that the welder quality management system of the shipyard/manufacturer includes as minimum:
    - (i) A designated person responsible for the coordination of the welder quality management system.
    - (ii) List of welders and welding supervisors in shipyard/manufacturer
    - (iii) If applicable, list of subcontracted welders
    - (iv) Qualification certificate of welders and description of the associated management system
    - (v) Training requirements for welder qualification programme
    - (vi) Identification system for welders and WPS used on welds
    - (vii) Procedure describing the system in place to monitor each welder performance based on results of welds examination records(e.g. repair rate, etc.) including the criteria permitting the maintenance of the welder qualification without retesting.
  - (c) The shipyards/manufacturers have to document at least once a year that the welder has produced acceptable welds in accordance with construction quality standards and Society's requirements in the welding positions, type of welds and backing conditions covered by its certificate. Which documents are required and how to document the evidences should be in agreement between the Society and the shipyards/manufacturers.
- (D) If, despite the preceding (A) ~ (C), you have completed the revalidation of the qualification within one month after the expiration date of qualification, you may be deemed to have maintained the approval for the period from the expiration date to the completion of the revalidation. When the revalidation is completed, the validity of the qualifications is to be as given in (A) ~ (C).
- (2) The welder has to be verified compliance with the conditions of (1) above and the maintenance of the welder's qualification certificate is to be signed by the Surveyor.
  - (3) Welders who are not engaged in plates(including steel castings and forgings) welding for hull structural may omit the revalidation of qualifications. At this time, the manufacturer(shipbuilder) is to distinguish between the welders engaged in hull structural plate(including steel castings and forgings) welding and the other welders. (2019) (2023)

## Section 6 Welding Consumables

### 601. General

#### 1. Application

- (1) The covered electrodes for manual welding and gravity welding, wire/flux combinations for two run or multirun submerged arc welding, solid wire/gas combinations for arc welding, flux cored wires with or without gas for arc welding and consumables for use in electroslag and electrogas vertical welding specified in the Rules are to be approved by the Society in accordance with the requirements in this Section.
- (2) The welding consumables which are used in welding processes differing from those specified in (1) or where it is considered impracticable to apply the requirements in this Section are to be of the type approved by the Society.
- (3) The approval test for welding consumables which are not covered by this Section is to be left to the discretion of the Society. **【See Guidance】**

#### 2. Process of manufacture

The approved welding consumables are to be manufactured of uniform quality, under the manufacturer's responsibility, by the process approved by the Society, at works approved by the Society.

#### 3. Test assemblies

- (1) The test assemblies are to be prepared under the supervision of the Surveyor, and all tests are to be carried out in his presence.
- (2) When a welded joint is performed, the edges of the plates are to be bevelled either by mechanical machining or by oxygen cutting; in the later case, a descaling of the bevelled edges is necessary.
- (3) The welding conditions used such as amperage, voltage, travel speed, etc are to be within the range recommended by the manufacturer for normal good welding practice. Where a filler material is stated to be suitable for both alternating current (AC) and direct current (DC), AC is to be used for the preparation of the test assemblies.

#### 4. Approval test

- (1) The approved welding consumables are subject to the approval tests and inspections specified in **602.** to **609.** in this Section.
- (2) Welding consumables are to be approved at each manufacturing plant and for each brand. However, where are specified in (a) and/or (b) below, a reduced test programme at least equivalent to annual tests is permitted if the manufacturer can certify that the materials used and the fabrication process are identical with those used in the main works. However, should there be any doubt, complete test-series may be required.
  - (a) Where welding consumables which have been approved are intended to manufacture at manufacturing plants other than those of the manufacturers who manufacture the said welding consumables.
  - (b) Where welding consumables which have been approved are intended to manufacture according to technical licensing agreements with those parties who manufacture the said welding consumables.
- (3) Wire flux combination for submerged arc welding. If a unique powder flux is combined with different wires coming from several factories belonging to the same firm, it may be admitted to perform only one test-series if the different wires are conformable to the same technical specification, after approval of the Society.
- (4) Where deemed necessary by the Society, tests other than those specified in this Section may be required.

#### 5. Periodical inspection

The manufacturer of welding materials is annually to be subjected to the periodical inspection in the presence of Surveyor for each brands of the welding materials at each manufacturing plant. (2024)

#### 6. Alterations to approved consumables

- (1) In case when the particulars of the welding materials which being mentioned in the certificate of approval, such as grade, welding position, maximum diameter of welding materials or shield gas,

- are changed, the manufacturer is to submit a copy of application form for change to the Society, and necessary additional approval tests are to be carried out accordingly.
- (2) When the significant changes in compositions or manufacturing process of the wire and flux or removal of manufacturing plant is made, the manufacturer is to submit a single copy of notification of alternation in any preferred form to the Society, and necessary confirmation survey and test may be carried out accordingly.
  - (3) Upgrading and uprating of welding consumables will be considered only at manufacturer's request, preferably at the time of annual testing. Generally, for upgrading of the strength or toughness, tests from butt weld assemblies will be required in addition to the normal annual approval tests. Generally, for uprating of hydrogen, hydrogen test will be required in addition to the normal annual approval tests. (2017)

## 7. Retests

- (1) *Tensile test and bend test*
  - (a) Where the tensile test and bend test fail to meet the requirements, twice as many test specimens as the number of specimens of failed test are to be selected from the first test material or from a test material welded under the same welding conditions, and if all of test specimens pass the tests, then the tests are considered to be successful.
  - (b) Where insufficient original welded assembly is available, a new assembly is to be prepared using welding consumables from the same batch.
  - (c) If the new assembly is made with the same procedure (particularly the number of runs) as the original assembly, only the duplicate re-test specimens needs to be prepared and tested. Otherwise, all test specimens should be prepared as for re-testing.
- (2) *Impact test*
  - (a) Where the result of the impact test is unsatisfactory, additional tests may be carried out, with the exception of the cases specified in (i) and (ii) below, by taking a set of test specimens out of the same test material from which the above-mentioned test specimens have been taken.
    - (i) The absorbed energy of all test specimens is under the required average absorbed energy.
    - (ii) The absorbed energy of two of the test specimens is under 70 % the required average absorbed energy.
  - (b) In case of the previous (a), the test specimens may be accepted, provided that the average absorbed energy of the six test specimens, including those which have been rejected as unsatisfactory, is not less than the required average absorbed energy, and that not more than two individual results are lower than the required average absorb energy and of these, not more than one result is below 70 % of the required average absorbed energy.
- (3) Where the retest fails to meet the requirements, the test may be made over again with changed welding conditions. In this case, if the whole tests specified for the test assembly are carried out and are in compliance with the requirements, the test is accepted as successful.

## 8. Revocation of approval

In the following cases, the approval of welding consumables by the Society shall be revoked, after notice is given to the manufacturer:

- (1) When the Society has recognized that the quality is remarkably worse than that approved or is not uniform.
- (2) When the welding consumables have failed the requirements in the annual inspections.
- (3) When the welding consumables are not inspected annually as required by the Rules.

## 9. Data

The Society may require the submission of the data with respect to the properties of welding consumables if necessary.

## 10. Packings and markings

- (1) The approved welding consumables are to be packed throughly to keep the quality during their transportation and storage.
- (2) All packages of approved welding consumables are to clearly marked with the following descriptions. (2019)
  - (a) Brand

- (b) Specification and classification
- (c) Name of manufacturer and supplier
- (d) Number (lot, control or heat number) of production (2024)
- (e) Special notices on the treatment

**602. Electrodes for manual arc welding for normal strength steels, higher strength steels and steels for low temperature service**

**1. Application**

- (1) Electrodes for manual arc welding for normal strength steels, higher strength steels and steels for low temperature service given in the following (a) and (b) (hereinafter referred to as "electrodes") are to be subjected to the approval test and annual inspections in accordance with the requirements in **602..**
  - (a) Electrodes for manual welding
    - (i) For butt welds
    - (ii) For fillet welds
    - (iii) For both butt welds and fillet welds
  - (b) Electrodes used in gravity welding or similar set-ups
    - (i) For fillet welds
    - (ii) For both butt welds and fillet welds
- (2) Any requirements regarding one side welding without backing are left to the discretion of the Society. **【See Guidance】**

**2. Grades and marks of electrode**

- (1) Electrodes are classified as specified in **Table 2.2.25**.

**Table 2.2.25 Grades and Marks (2017) (2021)**

For normal strength steel	For higher strength steel	For steel for low temperature service
1, 2, 3	2Y, 3Y, 4Y, 5Y, 2Y40, 3Y40, 4Y40, 5Y40, 3Y47	L 1, L 2, L 3, L 51, L 91

- (2) For low hydrogen electrodes which have passed the hydrogen test specified in **Par 6**, the suffixes given in **Table 2.2.32** are to be added to the grade marks of the said electrodes. (e.g. 2Y H5)

**3. General provisions for tests**

- (1) Kinds of test, number, thickness and dimension of test assemblies, diameter of electrodes used for welding, welding positions, grades and number of test specimens to be taken from each test assembly for electrodes given in **Par 1 (1) (a) (i) and (iii)** are to be as given in **Table 2.2.26**. However, where deemed necessary by the Society, hot cracking tests may be required by the Society in addition to tests specified in this Table. **【See Guidance】**
- (2) Kinds of test, number, thickness and dimension of test assemblies, diameter of electrodes used for welding and welding positions, together with grades and number of test specimens to be taken from each test assembly for electrodes given in **Par 1 (1) (a) (ii)**, are to be as given in **Table 2.2.27**.
- (3) Tests for electrodes given in **Par 1 (1) (b)** are to be in accordance with the requirements in the following (a) and (b):
  - (a) For electrodes given in **Par 1 (1) (b) (i)**, tests given in **Table 2.2.27** specified in the preceding (2) are to be conducted.
  - (b) For electrodes given in **Par 1 (1) (b) (ii)**, tests specified in the preceding (a) and butt weld test given in **Table 2.2.27** specified in the preceding (1) are to be conducted.

Table 2.2.26 Kinds of Test for Electrode

Kind of test	Test assembly					Kind and No. of test specimens taken from test assembly
	Welding position	Diameter of electrode (mm)	No. of test assemblies	Dimensions of test assembly	Thickness (mm)	
Deposited metal test	Flat	4	1 <sup>(1)</sup>	Fig 2.2.22	20	Tensile test specimen : 1 Impact test specimen : 3
		max. diameter	1 <sup>(1)</sup>			
Butt weld test	Flat	First run. 4; Subsequent runs:5 or over; Last two runs. max. dia.	1	Fig 2.2.24	15~20	Tensile test specimen : 1 Face bend specimen : 1 Root bend specimen : 1 Impact test specimen : 3 <sup>(5)</sup>
		First run. 4; Second run,5 or 6; Subsequent runs. max. dia.	1 <sup>(2)</sup>			
	Horizontal <sup>(4)</sup>	First run. 4 or 5 Subsequent runs, 5	1			
	Vertical upward	First run. 3.2; Subsequent runs. 4 or 5	1			
	Vertical downward	<sup>(3)</sup>	1			
	Overhead	First run. 3.2; Subsequent runs. 4 or 5	1			
Fillet weld test <sup>(6)</sup>	Horizontal	One side; max. dia. The other side; min. dia.	1	Fig 2.2.25	20	Macro structure test specimen : 3 <sup>(8)</sup> Hardness test specimen : 3 <sup>(8)</sup> Fracture test specimen : 2
Hydrogen test <sup>(7)</sup>	Flat	4	4	<sup>(9)</sup>	12	Hydrogen test specimen : 1

NOTES:

- (1) Where the diameter of the manufactured electrodes is of one type, there is to be one test assembly. If 4 mm is the largest size, two test assemblies including 4 mm and other largest size are required. (2019)
- (2) Where the tests are conducted solely in the downhand position, this test assembly has been added.
- (3) Electrodes with diameters specified by the manufacturers are to be used.
- (4) For electrodes which have passed butt weld tests in the downhand and vertical upward positions, test in the horizontal position may be omitted subject to approval by the Society.
- (5) Impact tests are not to conduct for overhead welds.
- (6) This test is added solely for electrodes used in both butt welds and fillet welds.
- (7) This test is to conduct solely for low hydrogen electrodes.
- (8) Test specimens used in macro structure test and hardness tests are considered to be the same.
- (9) Dimensions of test assembly are to be as specified in 602. 6.

- (4) Where electrodes are intended to be used for both items specified in Par 1 (1) (a) and (b), approval tests required for each electrode are to be conducted. However, deposited metal tests may be omitted for electrodes given in Par 1 (1) (b).
- (5) Steel plates to be used in preparation of test assemblies are to be as given in Table 2.2.28 according to the grades of electrode.
- (6) The welding conditions used such as amperage, voltage, travel speed, etc. are to be within the range recommended by the manufacturer for normal good welding practice. Where a filler metal is stated to be suitable for both alternating current (AC) and direct current (DC), AC is to be used for the preparation of the test assemblies.
- (7) For the approval of electrodes, the tests specified in the preceding (1) to (4) are to be conducted for each brand of electrodes.
- (8) After welding, the test assemblies are not to be subjected to any heat treatment.

Table 2.2.27 Kinds of Test for Electrode

Kind of test	Test assembly					Kind and No. of test specimens taken from test assembly
	Welding position	Diameter of electrode (mm)	No. of test assemblies	Dimensions of test assembly	Thickness (mm)	
Deposited metal test	Flat	4	1	Fig 2.2.22	20	Tensile test specimen : 1 Impact test specimen : 3
		max. diameter	1			
Fillet weld test	Flat	One side; max. dia. The other side; min. dia.	1	Fig 2.2.25	20	Macro structure test specimen : 3 <sup>(1)</sup> Hardness test specimen : 3 <sup>(1)</sup> Fracture test specimen : 2
	Horizontal-vertical		1			
	Vertical upward		1			
	Vertical downward		1			
	Overhead		1			
Hydrogen test <sup>(2)</sup>	Flat	4	4	<sup>(3)</sup>	12	Hydrogen test specimen : 1

NOTES:  
 (1) Test specimens used in macro tests and hardness tests are considered to be the same.  
 (2) This test is to conduct solely for low hydrogen electrodes.  
 (3) Dimensions of test assembly are to be as specified in 602. 2. 6.



**Table 2.2.28 Grade of Steels used for Test Assembly (2017) (2021)**

Grade of electrode	Grade of steels used for test assembly <sup>(1)(2)</sup>
1	A
2	A, B or D
3	A, B, D or E
2Y	AH 32, AH 36, DH 32 or DH 36
3Y	AH 32, AH 36, DH 32, DH 36, EH 32 or EH 36
4Y	AH 32, AH 36, DH 32, DH 36, EH 32, EH 36, FH 32 or FH 36
5Y	AH 32, AH 36, DH 32, DH 36, EH 32, EH 36, FH 32 or FH 36
2Y40	AH 40 or DH 40
3Y40	AH 40, DH 40 or EH 40
4Y40	AH 40, DH 40, EH 40 or FH 40
5Y40	AH 40, DH 40, EH 40 or FH 40
3Y47	EH 47-H
L 1	E or RL 24A
L 2	E, RL 235A, RL 235B, RL 325A or RL 325B
L 3	RL 325A, RL 325B or RL 355
L 51	RL 5N390
L 91	RL 9N490
<p>NOTES:</p> <p>(1) Notwithstanding the requirements in this Table normal strength or higher strength steel may be used for the deposited metal test assembly. In this case, test assemblies of grade L 91 are to be appropriately buttered.</p> <p>(2) The tensile strength of higher strength steels AH 32, DH 32, EH 32, and FH 32 used in butt weld test assemblies is to be greater than 490 N/mm<sup>2</sup>.</p>	

- (9) It is recommended that the welded assemblies be subjected to a radiographic examination to ascertain that there are any defects in the weld prior to the preparation of test specimens.

#### 4. Deposited metal test

##### (1) Welding of deposited metal test assemblies

- (a) Test assembly as shown in **Fig 2.2.22** is to be welded in the downhand position according to the normal practice.
- (b) The weld metal is to be deposited in single or multi-run layers according to normal practice, and the direction of each run is to alternate from each end of the plate, each run of weld metal being not less than 2 mm but not more than 4 mm thick.
- (c) After each run, the test assembly is to be left in still air until it has cooled to less than 25 0°C but not below 100°C, the temperature being taken at the centre of the weld on the surface of seam.

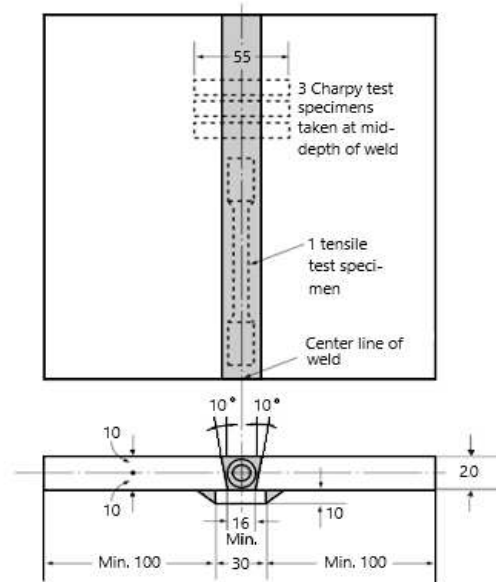


Fig 2.2.22 Deposited Metal Test Assembly for Electrode for Manual Arc Welding (unit : mm)

(2) *Chemical analysis*

The chemical analysis of the deposited weld metal in each test assembly is to be supplied by the manufacturer and is to include the content of all significant alloying element.

(3) *Deposited metal tensile test*

- The tensile test specimen, one from each test assembly, is to be machined to dimensions R14A test specimen as shown in **Table 2.2.1**, care being taken that the longitudinal axis coincides with the centre of weld and the mid-thickness of plates.
- The tensile test specimen may be subjected to a temperature not exceeding 250 °C for a period not exceeding 16 hours for hydrogen removal prior to testing.
- The tensile strength, yield strength and elongation of each test specimen are to comply with the requirements given in **Table 2.2.29**, where the upper limit of tensile strength is exceeded, special consideration will be given to the approval of the electrode, taking into consideration of the other mechanical properties shown in the test results and the chemical composition of deposited metal.

(4) *Deposited metal impact tests*

- One set of three impact test specimens, from each test assembly, are to be machined to dimensions charpy V-notch impact test specimen as shown in **Table 2.1.3**. The test specimen is to be cut with its longitudinal axis transverse to the direction of welding, and the test specimen is to coincide with the mid-thickness of the plate shown in **Fig 2.2.23**.
- The notch is to be positioned in the centre of weld and is to be cut in the face of test specimens perpendicular to the surface of plate.

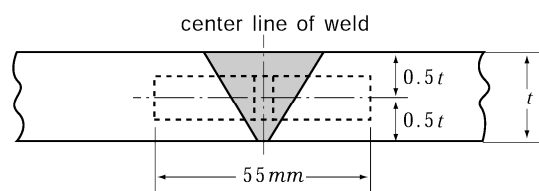


Fig 2.2.23 Position of Butt Weld Impact Test Specimen  
(Unit : mm, t : plate thickness)

- Test temperature and average absorbed energy are to comply with the requirements given in **Table 2.2.29**.

**Table 2.2.29 Tensile and impact Test Requirements for Deposited Metal (2017) (2021)**

Grade of electrode	Tensile strength (N/mm <sup>2</sup> )	Yield strength (N/mm <sup>2</sup> )	Elongation (%)	Impact test	
				Test temp. (°C)	Average absorbed energy(J)
1	400 ~ 560	305 min.	22 min.	20	47 min.
2				0	
3				-20	
2Y	490 ~ 660	375 min.	22 min.	0	
3Y				-20	
4Y				-40	
5Y				-60	
2Y40	510 ~ 690	400 min.	22 min.	0	
3Y40				-20	
4Y40				-40	
5Y40				-60	
3Y47	570 ~ 720	460 min.	19 min.	-20	64 min.
L 1	400 ~ 560	305 min.	22 min.	-40	34 min.
L 2	440 ~ 610	345 min.	22 min.	-60	
L 3	490 ~ 660	375 min.	21 min.	-60	
L 51	530 min.	375 min. <sup>(1)</sup>	25 min.	-120	27 min.
L 91	590 min.	375 min. <sup>(1)</sup>	25 min.	-196	27 min.
NOTE: (1) 0.2 % Yield strength					

(d) When the absorbed energy of two or more test specimens among a set of test specimens is less in value than the specified average absorbed energy or when the absorbed energy of a single test specimen is less in value than 70 % of the specified average absorbed energy, the test is considered to have failed.

## 5. Butt weld test

### (1) Welding of butt weld test assemblies

- Test assembly as shown in **Fig 2.2.24** is to be welded in each welding position (flat, horizontal-vertical, vertical-upward, vertical downward and overhead) which is recommended by the manufacturer, according to the normal practice.
- Test assembly is to be left in still air until it has cooled to less than 250°C but not below 100°C, the temperature being taken at the centre of the weld on the surface of seam.

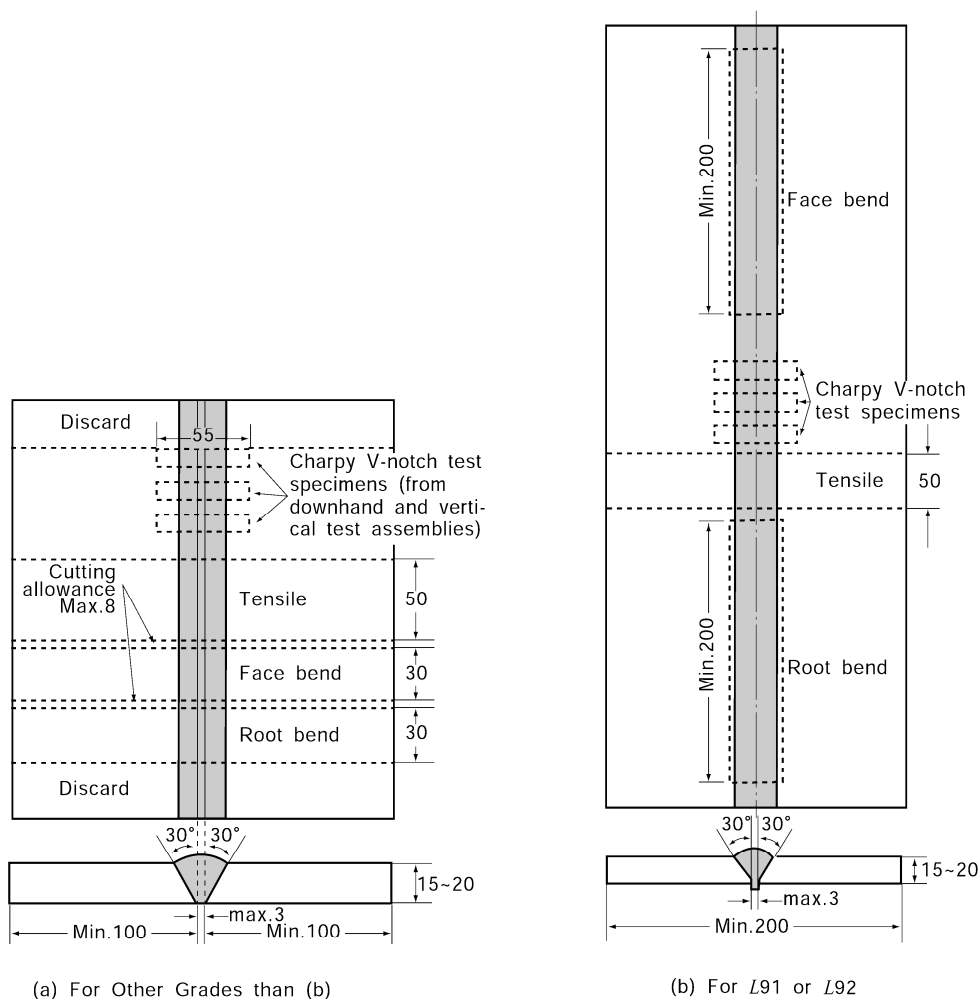


Fig 2.2.24 Butt weld Test Assembly for Electrode for Manual Arc Welding (Unit: mm)

- (c) In all cases, the back sealing runs are to be made with 4 mm electrode in the welding position appropriate to each test assembly, after cutting out the root run to clean metal. For electrodes suitable for downhand welding only, the test assemblies may be turned over to carry out the back sealing run.
- (2) *Butt weld tensile tests*
- The tensile test specimen is to be *R2A* specimen shown in **Table 2.2.1** and the test specimen is to be taken from each test assembly.
  - The surface of weld is to be machined flush with the surface of plate.
  - The tensile strength of test specimen is to comply with the requirements given in **Table 2.2.30**.
- (3) *Butt weld bend test*
- The face and root bend test specimens are to be *RB4* specimen shown in **Table 2.2.2**, and test specimens are to be taken from each test assembly. However, for *L91*, the face and root bend specimens are to be *RB1* specimen shown in **Table 2.2.2**, and test specimens are to be taken longitudinally from each test assembly.
  - The upper and lower surfaces of the weld are to be filed, ground or machined flush with the surface of the plate and the sharp corners of the specimens rounded to a radius not exceeding 2 mm.
  - The test specimens are to be capable of withstanding, without crack exceeding 3 mm long on the outer surface of other defects, being bent through an angle of 120 degrees over a former having a radius of 1.5 times (2 times for 3Y47) the thickness of test specimen. The radius and angle of the former for *L91*, however, are to be 2 times the thickness of the specimen and 180 degrees respectively.

**Table 2.2.30 Tensile and impact Test Requirements for butt weld (2017) (2021)**

Grade of electrode	Tensile strength (N/mm <sup>2</sup> )	Impact test		
		Test temp. (°C)	Average absorbed energy (J)	
			Flat, Horizontal, Overhead	Vertical upward Vertical downward
1	400 min.	20	47 min.	34 min.
2		0		
3		-20		
2Y	490 min.	0		
3Y		-20		
4Y		-40		
5Y		-60		
2Y40	510 min.	0	39 min.	
3Y40		-20		
4Y40		-40		
5Y40		-60		
3Y47	570 min.	-20	64 min.	64 min.
L 1	400 min.	-40	27 min.	27 min.
L 2	440 min.	-60		
L 3	490 min.	-60		
L 51	530 min.	-120		
L 91	630 min.	-196		

(4) *Butt weld impact tests*

- (a) One set of three impact test specimens, from each test assembly, are to be machined to dimensions charpy V-notch impact test specimens as shown in **Table 2.1.3**.
- (b) The test specimens are to be prepared as shown in **Fig 2.2.23** and the dimensions, form, position and direction of notches are to be as specified in **Par 4. (4)**.
- (c) Test temperature and average absorbed energy are to comply with the requirements given in **Table 2.2.30**, appropriate to the grades of the electrode and welding position.
- (d) When the absorbed energy of two or more test specimens among a set of test specimens is less in value than the specified average absorbed energy or when the absorbed energy of a single test specimen is less in value than 70 % of the specified average absorbed energy, the test is considered to have failed.

**6. Hydrogen test**

The hydrogen test to be carried out by the mercury method or thermal conductivity detector method. The use of the glycerine method may be admitted at the Society discretion. (2017)

- (1) The mercury method to be as specified in the Standard *ISO 3690:2018. (2017) (2023)*
- (2) The thermal conductivity detector method is to be as specified in *ISO 3690:2018*. Four weld assemblies are to be prepared. The temperature of the specimens and minimum holding time are to be complied with **Table 2.2.31**, according to the measuring method respectively. (2017) (2023)
- (3) Glycerin method
  - (a) *Welding of test assemblies*
    - (i) As a rule, mild and high tensile steels are to be used for the test assembly, and four test specimens are to be prepared measuring 12 mm by 25 mm in cross section by about 125 mm in length. Before welding, the specimens are to be weighed to the nearest 0.1 gram. On the 25 mm surface of each test specimen, a single bead of welding is to be deposited, about 100 mm in length, by a 4 mm electrode, using about 150 mm of the electrode. The welding is to be carried out with as short an arc as possible and with a current of about 150 amp.

- (ii) The electrodes, prior to welding, can be submitted to the normal drying process recommended by the manufacturer.
- (b) After welding, each test specimen prepared to the hydrogen test specified in (a) above is to be quenched in water at a temperature of approximately 20 °C for 30 sec, after removing the slag within a period of 30 sec. Subsequently, the test specimens are to be cleaned and be sealed into a hydrogen collector by means of the glycerin replacement method. The glycerin is to be kept at a temperature of approximately 45°C during the test. The test time required for all the four test specimens from welding to the enclosure in the hydrogen collector is to be within 30 min. After immersing into glycerin for 48 hours, the test specimens are to be cleaned with water and alcohol and weighed with an accuracy of 0.1 g after being dried to measure the weight of the deposited metal. The volume of hydrogen gas collected is to be measured with an accuracy of 0.05 cm<sup>3</sup> and converted into that under the conditions 20 °C and 1 atmospheric pressure (760 mm Hg).

**Table 2.2.31 Test temperature and minimum holding time (2017)**

Measuring method		Test temperature	Minimum holding time
Thermal conductivity detector method <sup>(1)</sup>	Gas chromatography	45 °C	72 hour
		150 °C	6 hour
NOTES:			
(1) The use of hot carrier gas extraction method may be considered subject to verification of the testing procedure to confirm that collection and measurement of the hydrogen occurs continuously until all of the diffusible hydrogen is quantified.			

- (4) Average diffusible hydrogen contents of the four specimens is to comply with the requirements given in **Table 2.2.32** according to the test procedures specified in preceding articles or the type of suffixes to be added to the grade marks.

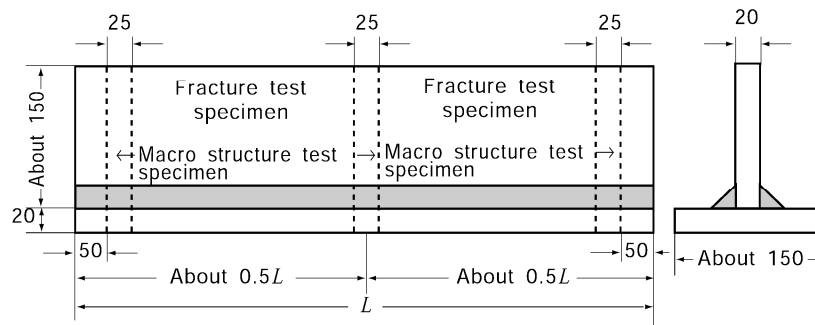
**Table 2.2.32 Requirements for Hydrogen Contents (ml/100g) (2017)**

Mark	Mercury method	Thermal conductivity detector method	Glycerine method
H15	15 max.	15 max.	10 max.
H10	10 max.	10 max.	5 max.
H5	5 max.	5 max.	-

## 7. Fillet weld test

### (1) Welding of fillet weld test assemblies

- (a) Test assembly as shown in **Fig 2.2.25** is to be welded in each welding position (flat, horizon-vertical, vertical-up ward, vertical-downward and overhead) which is recommended by the manufacturer.
- (b) The first side is to be welded using the maximum size of electrode manufactured and the second side is to be welded using the minimum size of electrode manufactured.
- (c) The leg length of fillet welds may will in general be determined by the electrode size and the welding current employed during testing.
- (d) In case of fillet welds using gravity or similar contact welding method, the fillet welding is to be carried out with electrodes of maximum length. Where approval is requested for the welding of both normal strength and higher strength steel, the assemblies are to be prepared using higher strength steel.



(The length of the test assemblies  $L$  is to be sufficient to allow at least the deposition of the entire length of the electrode being tested.)

Fig 2.2.25 Fillet Weld Test Assembly (Unit : mm)

(2) *Fillet weld macro-structure test*

- (a) For macro-structure test specimens, those with breadths of 25 mm are selected from three places shown in Fig 2.2.25.
- (b) The macro-etching test is conducted on the transverse section of fillet weld joint and welded joints are to be free from excessive difference of leg length between upper and lower, cracks and other injurious defects.

- (3) *Fillet weld hardness test* The hardness of weld metal, heat affected zone and base metal are to be measured at places given in Fig 2.2.26 for each test specimen which underwent the macro-etching test specified in preceding (1) and the respective hardnesses are to be in accordance with those deemed appropriate by the Society. **[See Guidance]**

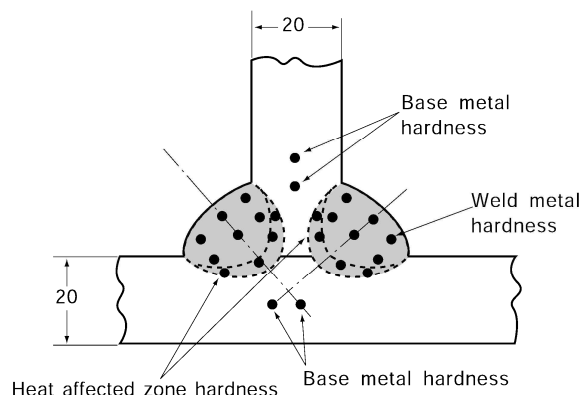


Fig 2.2.26 Hardness Test (Unit : mm)

(4) *Fillet weld fracture test*

- (a) One of the remaining sections of the fillet weld is to have the weld on the first side gouged or machined to facilitate breaking the fillet weld as shown in Fig 2.2.27, on the second side by closing the two plates together, submitting the root of the weld to tension. On the other remaining section the weld on the second side is to be gouged or machined and the section fractured using the same procedure.
- (b) The fractured surfaces are to be examined and there should be no evidence of incomplete penetration, or internal cracking and they should be reasonably free from porosity.

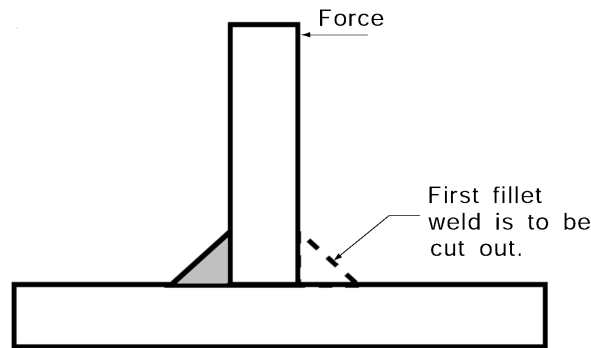


Fig 2.2.27 Fracture Test

### 8. Annual inspections

- (1) In the annual inspections, tests specified in the following (2) and (3) are to be conducted for each brand of the approved electrodes and they are to be passed satisfactorily.
- (2) The kinds of test, etc. in the annual inspections for manual arc welding electrodes are to be as given in **Table 2.2.33**.

Table 2.2.33 Kind of Test for Annual Inspection (2019)

Kind of test <sup>(2)</sup>	Test assembly					Kind and no. of test specimens taken from test assembly
	Welding position	Diameter of electrode (mm)	Number	Dimensions	Thickness (mm)	
Deposited metal test	Flat	4 <sup>(1)</sup>	1	Fig 2.2.21	20	Tensile test specimen : 1 Impact test specimen : 3
		max. diameter <sup>(1)</sup>	1			
NOTES: (1) Where the diameter of the manufactured electrodes is of one type, there is to be one test assembly. If 4 mm is the largest size, two test assemblies including 4 mm and other largest size are required. (2) For low hydrogen electrodes, an hydrogen test can also be required at the discretion of the Society.						

- (3) The kinds of test, etc. in the annual inspections of electrodes used in gravity welding or other welding using similar welding devices are to be as given in **Table 2.2.34**.
- (4) The welding procedures and requirements for test assemblies of tests specified in the preceding (2) and (3) are to be as specified in **Par 4**.

Table 2.2.34 Kind of Test for Annual Inspection

Kind of test	Test assembly					Kind and no. of test specimens taken from test assembly
	Welding position	Diameter of electrode (mm)	Number	Dimensions	Thickness (mm)	
Deposited metal test	Flat	4 min.	1	Fig 2.2.21	20	Tensile test specimen : 1 Impact test specimen : 3

### 9. Changes in grades

- (1) Where changes in the grades relating to the strength or toughness or hydrogen of electrodes approved are to be made, tests specified in the following (2), (3) and (4) are to be carried out



- and satisfactorily passed in accordance with the requirements in **601. 6 (3)**. (2017)
- (2) For changes in the grades relating to strength, the butt weld tests, specified in the annual inspection of **Par 8** and in the requirements of **Par 3 (1)**, are to be conducted.
  - (3) For changes in the grades relating to toughness, the butt weld impact tests, specified in the annual inspection of **Par 8** and in the requirements of **Par 3 (1)**, are to be conducted.
  - (4) For uprating of hydrogen, the hydrogen test, specified in the annual inspection of **Par 8** and in the requirements of **Par 3 (1)**, are to be conducted. (2017)

**603. Automatic welding consumables for normal strength steels, higher strength steels and steels for low temperature service**

**1. Application**

- (1) Welding consumables for normal strength steels, higher strength steels and steels for low temperature service given in the following (a) through (c) (hereinafter referred to as "automatic welding consumables") are to be subjected to the approval tests and annual inspections in accordance with the requirements in **603**.
  - (a) Submerged arc automatic welding consumables (Wire flux combinations)
  - (b) Gas shielded arc automatic welding consumables (Flux cored wire and solid wire automatic welding consumables with shielding gas)
  - (c) Self-shielded arc automatic welding consumables (flux-cored or flux-coated wires without a shielding gas)
- (2) Wire-flux combinations for multiple electrode submerged arc welding will be subject to separate approval tests. They are to be carried out generally in accordance with the requirements in **603**.
- (3) At the discretion of the Society, wires or wire-gas combinations approved for semi-automatic multirun welding may also be approved, without additional tests, for automatic multirun welding approval. This is generally the case when automatic multirun welding is performed in the same conditions of welding current and energy as semi automatic welding with the concerned wire-gas combination.

**2. Grades and marks**

- (1) The automatic welding consumables are classified as specified in **Table 2.2.35**.

**Table 2.2.35 Grade and Marks (2017) (2021)**

For normal strength steel	For higher strength steel	For steel for low temperature service
1, 2, 3	1Y, 2Y, 3Y, 4Y, 5Y 2Y40, 3Y40, 4Y40, 5Y40, 3Y47	L 1, L 2, L 3, L 51, L 91

- (2) Automatic welding materials which have passed the tests for each welding process given in **Table 2.2.38** are to be appended with the suffixes shown in **Table 2.2.36** at the end of their marks.
- (3) In the preceding (2), a suffix G will be added to the grade mark for gas shielded arc automatic welding consumables, and a suffix N will be added for self-shielded wire automatic welding consumables. Further, the type of gas used is to be as specified in **Table 2.2.37**, and the suffix given in **Table 2.2.37** will be added after the suffix G. (e.g. 3YTM G(M1))

**Table 2.2.36 Marks**

Welding technique	Mark
Multi-run technique <sup>(1)</sup>	M
Two-run technique <sup>(2)</sup>	T
Multi-run and two-run technique	TM
NOTES:	
(1) Multi-run technique refers to a welding process involving multiple passes.	
(2) Two-run technique refers to a welding process involving a single pass on both sides.	

Table 2.2.37 Kinds of Gas

Group	Type	Gas composition (Vol.%)			
		CO <sub>2</sub>	O <sub>2</sub>	H <sub>2</sub>	Ar <sup>(1)(2)</sup>
M 1	M 11	1~5	-	1~5	Rest
	M 12	1~5	-	-	Rest
	M 13	-	1~3	-	Rest
	M 14	1~5	1~3	-	Rest
M 2	M 21	6~25	-	-	Rest
	M 22	-	4~10	-	Rest
	M 23	6~25	1~8	-	Rest
M 3	M 31	26~50	-	-	Rest
	M 32	-	11~15	-	Rest
	M 33	6~50	9~15	-	Rest
C	C 1	100	-	-	-
	C 2	Rest	1~30	-	-
I	I 1	-	-	-	100
E	E 1	Except above			
NOTE:					
(1) Argon may be substituted by Helium up to 95 % of the Argon content.					
(2) Approval covers gas mixtures with equal or higher Helium contents only.					

### 3. General provisions for tests

- (1) Steel plates to be used for test assemblies are to be as given in **Table 2.2.38**, appropriate to the kind of automatic welding consumables.
- (2) Kinds of test, number, thickness and dimensions of test assemblies, grades and number of test specimens to be taken from each test assembly for automatic welding consumables are to be as given in **Table 2.2.39**.
- (3) For the approval of automatic welding consumables, the tests specified in the preceding (2) are to be conducted for each brand of automatic welding consumables.
- (4) For gas shielded arc automatic welding consumables, the test in the preceding (3) is to be performed for each type of gas given in **Table 2.2.37**. When the manufacturer of the material recommends gas types of the group of M1, M2, M3 or C in **Table 2.2.37** and the test is satisfactorily conducted in accordance with the preceding (3) on one of the gas type, the test on the other gas types belonging to the same group is allowed to be dispensed with at the discretion of the Society.
- (5) Unless otherwise agreed by the Society, additional approval tests are required when a shielding gas is used other than that used for the original approval tests.
- (6) The welding conditions used such as amperage, voltage, travel speed, etc. are to be within the range recommended by the manufacturer for normal good welding practice. Where a filler metal is stated to be suitable for both alternating current (AC) and direct current (DC), AC is to be used for the preparation of the test assemblies.

Table 2.2.38 Grades of Steel used for Test Assembly (2017) (2021)

Grade of welding consumable	Grade of steel used for test assembly <sup>(1)(2)</sup>
1	A
2	A, B or D
3	A, B, D or E
1Y	AH32 or AH36
2Y	AH32, AH36, DH32 or DH36
3Y	AH32, AH36, DH32, DH36, EH32 or EH36
4Y	AH32, AH36, DH32, DH36, EH32, EH36, FH32 or FH36
5Y	AH32, AH36, DH32, DH36, EH32, EH36, FH32 or FH36
2Y40	AH40 or DH40
3Y40	AH40, DH40 or EH40
4Y40	AH40, DH40, EH40 or FH40
5Y40	AH40, DH40, EH40 or FH40
3Y47	EH47-H
L1	E or RL235A
L2	E, RL235A, RL235B, RL325A or RL325B
L3	RL325A, RL325B or RL355
L51	RL5N390
L91	RL9N490
<p>NOTES:</p> <p>(1) Notwithstanding the requirements in this Table, normal strength steel or higher strength steels may be used for deposited metal test assembly. In this case, test assemblies of grade L91 are to be appropriately buttered.</p> <p>(2) The tensile strength of higher strength steels AH32, DH32, EH32 and FH32 used in butt weld test assemblies is to be greater than 490 N/mm<sup>2</sup></p>	

Table 2.2.39 Kinds of Test of Automatic Welding Consumables (2017)

Welding technique <sup>(7)</sup>	Kind of test <sup>(8)</sup>		Grade of welding consumables	Test assembly			Kinds and no. of test specimens taken from test assembly
				Number	Dimensions	Thickness (mm) <sup>(3)</sup>	
Multi-run technique	Deposited metal test		1, 2, 3	1	<b>Fig 2.2.28</b>	20	Tensile test specimen: 2 Impact test specimen: 3
	Butt weld test		1Y, 2Y, 3Y, 4Y, 5Y 2Y40, 3Y40, 4Y40, 5Y40 L1, L2, L3, L51, L91	1 <sup>(4)</sup>	<b>Fig 2.2.29</b>	20~25	Tensile test specimen: 2 <sup>(4)</sup> Face bend test specimen: 2 <sup>(4)(6)</sup> Root bend test specimen: 2 <sup>(4)(6)</sup> Impact test specimen: 3
Two-run technique	Butt weld test	Submerged arc welding	1, 1Y	1	<b>Fig 2.2.30</b>	12~15	Tensile test specimen: 2 Longitudinal tensile test specimen: 1 <sup>(5)</sup>
				1		20~25	Face bend test specimen: 1 Root bend test specimen: 1 Impact test specimen: 3
		Gas shielded and self-shielded arc welding	2, 3 2Y, 3Y, 4Y, 5Y 2Y40, 3Y40, 4Y40, 5Y40	1		20~25	Tensile test specimen: 2 Longitudinal tensile test specimen: 1 <sup>(5)</sup> Face bend test specimen: 1 Root bend test specimen: 1 Impact test specimen: 3
				1		30~35	
	Butt weld test	Gas shielded and self-shielded arc welding	1, 2, 3 1Y, 2Y, 3Y, 4Y, 5Y 2Y40, 3Y40, 4Y40, 5Y40	1		12~15 <sup>(1)</sup>	Tensile test specimen: 2 Longitudinal tensile test specimen: 1 <sup>(5)</sup> Face bend test specimen: 1 Root bend test specimen: 1 Impact test specimen: 3
						20 <sup>(2)</sup>	
			20~25 <sup>(1)</sup>				
			acceptable maximum thickness <sup>(2)</sup>				
Butt weld test		L1, L2, L3, L51, L91	1	12~15	Tensile test specimen: 2 Longitudinal tensile test specimen: 1 <sup>(5)</sup> Face bend test specimen: 1 Root bend test specimen: 1 Impact test specimen: 3		
			1	20 or acceptable maximum thickness			

NOTES:

- (1) Thickness of test assemblies where applied maximum plate thickness is not more than 25 mm.
- (2) Thickness of test assemblies where applied maximum plate thickness is more than 25 mm.
- (3) Where thickness is restricted by welding process, thickness of test assemblies may be changed upon approval of the Society. Test assemblies shall then be welded using plates of 12 to 15 mm and 20 to 25 mm irrespective of the grade for which the approval is requested.
- (4) The number of butt weld test assemblies for multi-run gas shielded and self-shielded arc welding techniques is to be one for each welding position. However, where there is more than one welding position, the number of tensile test specimens and bend test specimens selected from the test assemblies for each welding position may be half of the specified number.
- (5) Test specimens are to be selected from only the thicker of two test assemblies.
- (6) The number of face bend and root bend test specimens selected from the butt weld test assemblies for L 91 is to be one each.
- (7) Tests on both multi-run and two-run technique are to be conducted for multi-run and two-run welding respectively, and the number, dimensions and thickness of test assemblies, along with the grades and number of test specimens selected from each test assembly are to be according to each of the welding processes. However, the number of tensile test specimens in the deposited metal test for the multi-pass welding technique is to be one.
- (8) The hydrogen test may be applied by request of the manufacturer.
- (9) Where approval is requested for welding of both normal strength and higher strength steel two assemblies are to be prepared using higher strength steel. Two assemblies prepared using normal strength steel may also be required at the discretion of the Society.

- (7) After welding, the test assemblies are not to be subjected to any heat treatment.
- (8) It is recommended that the welded assemblies be subjected to a radiographic examination to ascertain that there are any defects in the weld prior to the preparation of test specimens.

#### 4. Deposited metal test with multi-run technique

(1) *Welding of deposited metal test assemblies*

- (a) Test assemblies as shown in **Fig 2.2.28** are to be welded in the flat position by multirun technique according to the normal practice. The direction of deposition of each run is to alternate from each end of the plate. After completion of each run, the flux and welding slag is to be removed.
- (b) The thickness of layer is not to be less than the diameter of wire nor less than 4 mm whichever is the greater for submerged arc automatic welding consumables. For gas shield and self-shielded arc automatic welding consumables the thickness of layer is not to be less than 3 mm.
- (c) After each run, the test assembly is to be left in still air until it has cooled to less than 25 0°C but not below 100°C, the temperature being taken at the centre of the weld on the surface of seam.

(2) *Chemical analysis*

The chemical analysis of the deposited weld metal in each test assembly is to be supplied by the manufacturer and is to include the content of all significant alloying element.

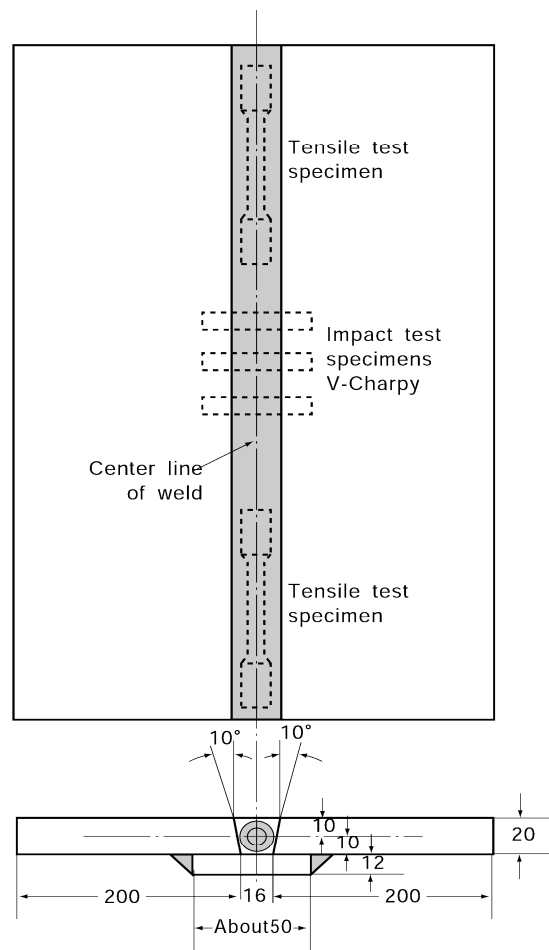


Fig 2.2.28 Deposited Metal Test Assembly with Multi-run Technique (Automatic Welding, Unit : mm)

- (3) *Deposited metal tensile test with multi-run technique*
- The tensile test specimens, two from each test assembly, are to be machined to dimensions R14A test specimen as shown in **Table 2.2.1**, care being taken that the longitudinal axis coincides with the centre of weld and the mid-thickness of plates.
  - The tensile strength, yield point and elongation of each test specimen are to comply with the requirements given in **Table 2.2.40**, where the upper limit of tensile strength is exceeded, special consideration will be given to the approval of the electrode, taking into consideration of the other mechanical properties shown in the test results and the chemical composition of deposited metal.
  - The tensile test specimens may be subjected to a temperature not exceeding 250 °C for a period not exceeding 16 hours for hydrogen removal prior to testing.
- (4) *Deposited metal impact test with multi-run technique*
- One set of three impact test specimens, from each test assembly, are to be machined to dimensions R4 test specimen as shown in **Table 2.1.3**. The test specimen is to be cut with its longitudinal axis transverse to the direction of welding, and the test specimen is to coincide with the mid-thickness of the plate shown in **Fig 2.2.22**.
  - Test temperature and average absorbed energy are to comply with the requirements given in **Table 2.2.40**.

**Table 2.2.40 Tensile and Impact Test Requirements for Deposited Metal test (2017) (2021)**

Grade of welding material	Tensile strength (N/mm <sup>2</sup> )	Yield strength (N/mm <sup>2</sup> )	Elongation (%)	Impact test	
				Test temp. (°C)	Average absorbed energy (J)
1	400 ~ 560	305 min.	22 min.	20	34 min.
2				0	
3				-20	
1Y	490 ~ 660	375 min.	22 min.	20	
2Y				0	
3Y				-20	
4Y				-40	
5Y				-60	
2Y40	510 ~ 690	400 min.	22 min.	0	39 min.
3Y40				-20	
4Y40				-40	
5Y40				-60	
3Y47	570 ~ 720	460 min.	19 min.	-20	64 min.
L 1	400 ~ 560	305 min.	22 min.	-40	27 min.
L 2	440 ~ 610	345 min.	22 min.	-60	
L 3	490 ~ 660	375 min.	21 min.	-60	
L 51	530 min.	375 min. <sup>(1)</sup>	25 min.	-120	
L 91	590 min.	375 min. <sup>(1)</sup>	25 min.	-196	
NOTE: (1) 0.2 % yield stress					

- (c) The notch is to be positioned in the centre of weld and is to be cut in the face of test specimens perpendicular to the surface of plate.
- (d) When the absorbed energy of two or more test specimens among a set of test specimens is less in value than the specified average absorbed energy or when the absorbed energy of a single test specimen is less in value than 70 % of the specified average absorbed energy, the test is considered to have failed.

#### 5. Butt weld test with multi-run technique

##### (1) Welding of butt weld test assemblies with multi-run technique

- (a) The face side of the test assemblies as shown in **Fig 2.2.29** is to be multi-pass welded in flat position, and the corresponding welding procedure is to follow the requirements of the preceding 4. (1). However, for gas shield arc and self shielded arc wire automatic welding consumables, the welding position is to be as specified by the manufacturer.
- (b) After completing the face welding in downhand position, back welding is performed. In this instance, back chipping may be carried out to expose sound deposited metal at the root.

##### (2) Butt weld tensile test with multi-run technique

- (a) The tensile test specimens are to be prepared to R2A specimen shown in **Table 2.2.1** and two test specimens are to be taken from each test assembly.
- (b) The surface of weld is to be machined flush with the surface of plate.
- (c) The tensile strength of test specimen is to comply with the requirements given in **Table 2.2.41**.

##### (3) Butt weld bend test with multi-run technique

- (a) The face bend and root bend test specimens are to be RB4 specimen shown in **Table 2.2.2**, and two test specimens are to be taken from each test assembly. However, for L 91, the

face bend and root bend specimens are to be *RB1* specimen shown in **Table 2.2.2**, and test specimens are to be taken longitudinally from each test assembly. (2017)

- (b) The test specimens are to be capable of withstanding, without crack exceeding 3 mm long on the outer surface of other defects, being bent through an angle of 120 degrees over a former having a radius of 1.5 times (2 times for 3/47) the thickness of test specimen. The radius and angle of the former for *L91*, however, are to be 2 times the thickness of the specimen and 180 degrees respectively. (2017) (2021)

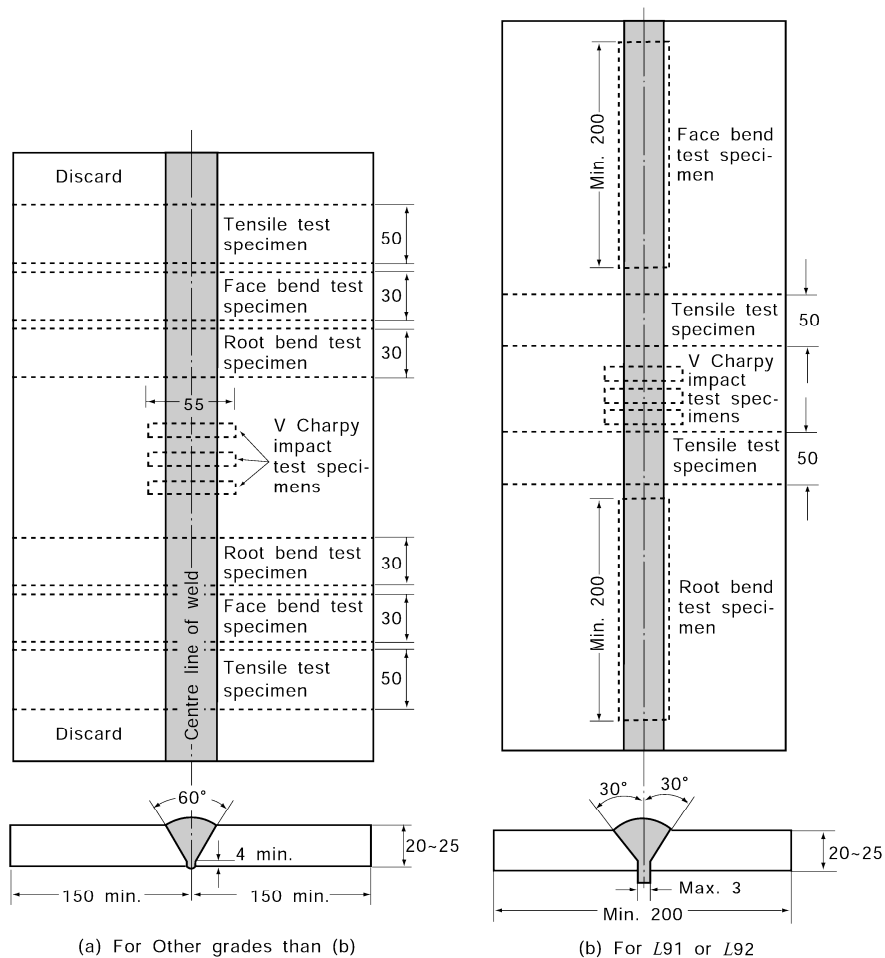


Fig 2.2.29 Butt Weld Test Assembly with Multi-run Technique (Automatic welding, Unit : mm)



**Table 2.2.41 Tensile and Impact Test Requirements for butt weld test with multi-run technique (2017) (2021)**

Grade of welding material	Tensile strength(N/mm <sup>2</sup> )	Impact test	
		Test temp. (°C)	Average absorbed energy (J)
1	400 min.	20	34 min.
2		0	
3		-20	
1Y	490 min.	20	
2Y		0	
3Y		-20	
4Y		-40	
5Y		-60	
2Y40	510 min.	0	
3Y40		-20	
4Y40		-40	
5Y40		-60	
3Y47	570 min.	-20	64 min.
L 1	400 min.	-40	27 min.
L 2	440 min.	-60	
L 3	490 min.	-60	
L 51	530 min.	-120	
L 91	630 min.	-196	

(4) *Butt weld impact test with multi-run technique*

- (a) One set of three impact test specimens, from each test assembly, are to be machined to dimensions R4 test specimens as shown in **Fig 2.1.3**. The test specimen is to be cut with its longitudinal axis perpendicular to the direction of welding, and the test specimen is to coincide with the mid-thickness of the plate shown in **Fig 2.2.23**.
- (b) Test temperature and average absorbed energy are to comply with the requirements given in **Table 2.2.41**.
- (c) The requirements in **Par 4.** (4), (c) and (d) are to correspondingly apply to this Paragraph.

**6. Butt weld test with two-run technique**

(1) *Welding of Butt weld test assemblies with two-run technique*

- (a) Test assemblies are to be prepared as shown in **Fig 2.2.30**, and the diameter of wire and edge preparation are to be as shown in **Fig 2.2.31**, but some deviation may be allowed where accepted by the Society.
- (b) Test assemblies are to be welded according to the normal practice in downhand position by two-run technique where each run is to be started alternately from each end of the plate. After completing the first run, the assembly is to be left in still air until it has cooled to 10 °C or below, the temperature being taken at the centre of weld on the surface of seam.

(2) *Chemical analysis*

The chemical analysis of the weld metal is to be supplied by the manufacturer, and is to include the content of all significant alloying elements.

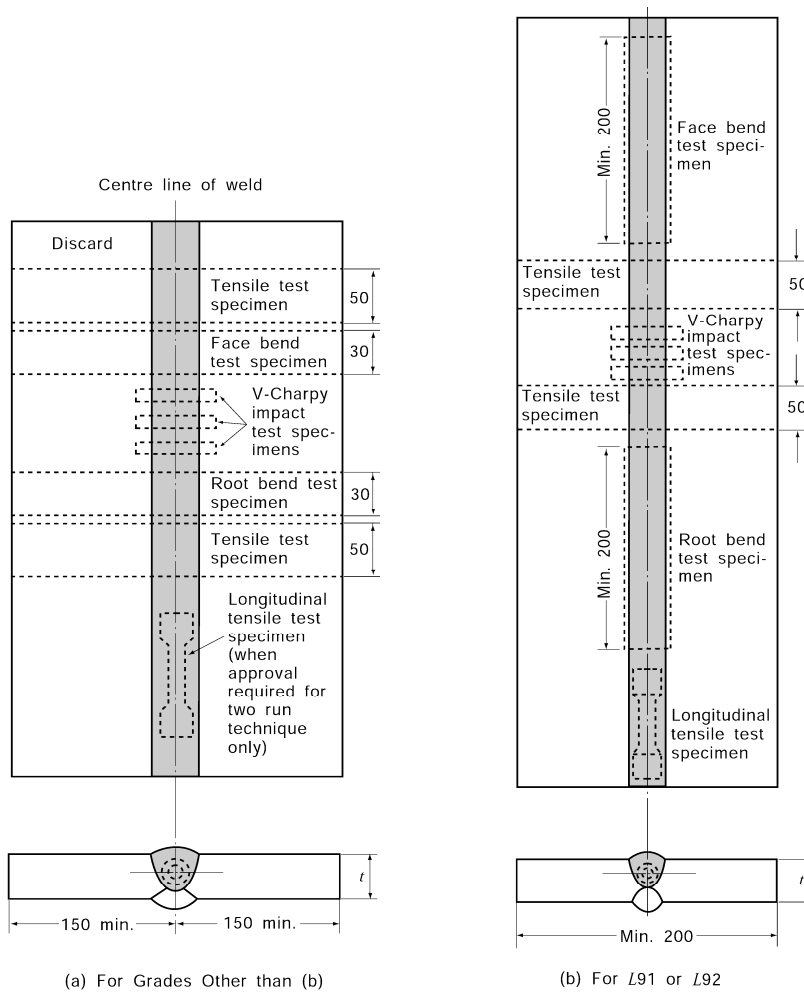


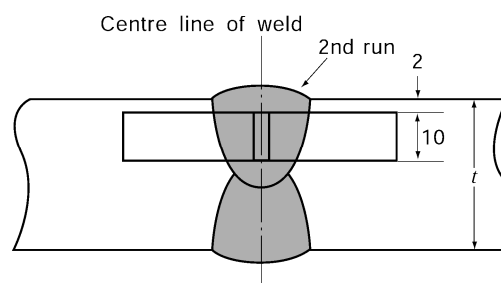
Fig 2.2.30 Buttt Weld Test Assembly with Two-run Technique (Automatic welding, Unit : mm, t : plate thickness)

(A) Submerged arc welding consumables			(B) Gas shielded arc and self shielded arc welding consumables		
Thickness of test assembly	Edge preparation <sup>(1)</sup>	Max. dia. of core	Thickness of test assembly	Edge preparation <sup>(2)</sup>	Max. dia. of wire
12-15		5	12-15		Maximum diameter of wire used is to be reported for information by manufacturer.
20-25		6			
30-35		7	20-25		

NOTES:  
 (1) Root gap is not to be greater than 1.0 mm.  
 (2) For assemblies using plate over 25 mm in thickness, the edge preparation used is to be specified by the manufacturer and the thickness of assembly is to comply with Table 2.2.28. (2).

Fig 2.2.31 Edge Preparation of Buttt Weld Test Assembly with Two-run Technique (t : plate thickness, Unit : mm)

- (3) *Butt weld tensile tests with two-run technique*
- The tensile test specimens are to be R2A specimen shown in **Table 2.2.1** and two test specimens are to be taken from each welded assembly.
  - The surface of weld is to be machined flush with the surface of plate.
  - The tensile strength of test specimen is to comply with the requirements given in **Table 2.2.41**.
  - One longitudinal tensile test specimen of R14A shown in **Table 2.2.1** is to be machined from the thicker of the test assembly specified in **Table 2.2.38** and the longitudinal direction of the test specimen is to be parallel to the weld line and the centre line of the test specimen is to coincide with the centre of second layer.
  - The longitudinal tensile test specimen in the preceding (4) may be subjected to a temperature not exceeding 250°C for a period not exceeding 16 *hours* for hydrogen removal prior to testing.
  - The requirements of tensile test specified in the preceding (d) and (e) are to be as given in **Table 2.2.33**. Where the upper limit of tensile strength is exceeded, special consideration will be given to the approval of the welding consumables, taking into consideration of the other mechanical properties shown in the test results and the chemical composition of deposited metal.
- (4) *Butt weld bend test with two-run technique*
- The face and root bend test specimens are to be RB4 or RB5 specimen shown in **Table 2.2.2** and test specimens are to be taken from each test assembly. However, for L91, the face and root bend test specimens are to be RB1 test specimens and test specimens shown in **Table 2.2.2** are to be taken longitudinally from each test assembly. (2017)
  - The requirements in **Par 5**. (3), (b) are to correspondingly apply to this Paragraph.
- (5) *Butt weld impact test with two-run technique*
- One set of three impact test specimens, from each test assembly, are to be machined to dimensions charpy V-notch impact test specimens as shown in **Table 2.1.3**, and the longitudinal direction of the test specimen is to be perpendicular to the weld line and the surface of weld about 2 mm apart is to coincide with the surface of specimen as shown in **Fig 2.2.32**.



**Fig 2.2.32 Position of impact Test Specimen for Butt Weld Test Assembly with Two-Run Technique**  
(Unit : mm, t : plate thickness)

- Test temperature and average absorbed energy are to comply with the requirements given in **Table 2.2.41**.
- The requirements in **Par 4**. (4), (c) and (d) are to correspondingly apply to this Paragraph.

## 7. Hydrogen test

The hydrogen test is to be in accordance with **602. 6** of the Rules

## 8. Annual inspections

- In the annual inspection, tests specified in the following (2) are to be conducted for each brand of the approved consumables, and they are to be passed satisfactorily.
- The kinds of test, etc. involved in the annual inspections are to be as given in **Table 2.2.42**.
- The welding procedures and requirements for test assemblies of tests specified in the preceding (2) are to be as specified in **Pars 4** through **6**.

Table 2.2.42 Kinds of Test for Annual Inspection (2017) (2021)

Grade of welding consumables	Welding technique (1)	Kind of test		Test assembly			Kinds and no. of test specimens taken from test assembly
				Number	Dimensions	Thickness (mm)	
1, 2, 3 1Y, 2Y, 3Y, 4Y, 5Y 2Y40, 3Y40, 4Y40, 5Y40, 3Y47 L1, L2, L3, L51, L91	Multi-run technique	Deposited metal test		1	Fig 2.2.28	20	Tensile test specimen: 1 Impact test specimen: 3
	Two-run technique	Butt weld test	Submerged arc welding	1	Fig 2.2.30	20	Tensile test specimen: 1 Longitudinal tensile test specimen: 1 Face bend test specimen: 1 Root bend test specimen: 1 Impact test specimen: 3
			Gas shielded and self shielded arc welding	1		20~25	Tensile test specimen: 1 Longitudinal tensile test specimen: 1 Face bend test specimen: 1 Root bend test specimen: 1 Impact test specimen: 3
<p>NOTE:</p> <p>(1) Tests on both multi-run and two run technique are to be conducted for multi-run and two run welding respectively. However, longitudinal tensile test of two run technique are not required.</p>							

### 9. Changes in grades

- (1) Where changes in the grades relating to the strength or toughness of automatic welding consumables approved are to be made, tests specified in the following (2), (3) and (4) are to be carried out and satisfactorily passed in accordance with the requirements in 601. 6 (3).
- (2) Changes in grades relating to the strength or toughness of multi-run automatic welding consumables are to be in accordance with the requirements in the following (a) and (b).
  - (a) For changes in the grades relating to strength, the butt weld tests, specified in the annual inspection of Par 8 and in the requirements of Par 3 (1), are to be conducted.
  - (b) For changes in the grades relating to toughness, the butt weld impact tests, specified in the annual inspection of Par 8 and in the requirements of Par 3 (1), are to be conducted.
- (3) Changes in grades relating to the strength or toughness of two-run automatic welding consumables are to be in accordance with the requirements in the following (a) and (b).
  - (a) For changes in the grades relating to strength, all tests specified in Par 3 (1) are to be conducted.
  - (b) For changes in the grades relating to toughness, the butt weld impact tests, specified in the annual inspections of Par 8 and in the requirements of the preceding (a), are to be conducted.
- (4) Changes in the grades relating to the strength or toughness of automatic welding consumables for multi-run and two-run use are to be as specified in the preceding (2) and (3).

**604. Semi-automatic welding consumables for normal strength steels, higher strength steels and steels for low temperature service**

**1. Application**

Welding consumables for semi-automatic welding for normal strength steels, higher strength steels and steels for low temperature service given in the following (a) and (b) (hereinafter referred to as "semi-automatic welding consumables") are to be subjected to the approval test and annual inspections in accordance with the requirements in **604**.

- (a) Gas shielded arc semi-automatic welding consumables (flux cored wire and solid wire semi-automatic welding consumables with shielding gas)
- (b) Self-shielded arc semi-automatic welding consumables (solid wire and flux cored wire semi-automatic welding consumables without shielding gas).

**2. Grades and marks**

- (1) The semi-automatic welding consumables are classified as specified in **Table 2.2.43**.

**Table 2.2.43 Grades and Marks (2017) (2021)**

For normal strength steel	For higher strength steel	For steel for low temperature service
1, 2, 3	1Y, 2Y, 3Y, 4Y 5Y 2Y40, 3Y40, 4Y40, 5Y40, 3Y47	L1, L2, L3, L51, L91

- (2) A suffix "S" will be added after the grade mark to indicate approval for semi-automatic multi-run welding. For wires intended for both semi-automatic and automatic welding, the suffixes will be added in combination. (eg. 3YSM)
- (3) A suffix G will be added to the grade marks for semi-automatic welding consumables which use shield gas, and a suffix N will be added for semi-automatic welding consumables which do not use shield gas. Further, the type of shield gas used is to be as specified in **Table 2.2.37**, and the suffix given in **Table 2.2.37** will be added after the suffix G. (e.g. 3YS G(M1))
- (4) For low hydrogen electrodes, which have passed the hydrogen test specified in **602. 6**, the suffixes given in **Table 2.2.32** are to be added to the end of the grade marks of the said electrode. (e.g. 3YS H5)

**3. General provisions for tests**

- (1) Kinds of test, number, thickness and dimensions of test assemblies, diameter of wire used for welding, welding position, grades and number of test specimens to be taken from each test assembly, position for semi-automatic welding consumables used in butt welds or in both butt and fillet welds are to be as given in **Table 2.2.44**.
- (2) Kinds of test, number, thickness and dimensions of test assemblies, diameter of wire used for welding, welding position, grades and number of test specimens to be taken from each test assembly for semi-automatic welding materials used in fillet welds only are to be as given in **Table 2.2.27**.
- (3) Steel plates to be used for test assemblies are to be as given in **Table 2.2.45**, appropriate to the kind of semi-automatic welding consumables.
- (4) For the approval of semi-automatic welding consumables, the test specified in the preceding (1) and (2) are to be conducted for each brand of semi-automatic welding consumables.
- (5) For semi-automatic welding consumables, the test in the preceding (4) is to be performed for each type of gas given in **Table 2.2.37**. When the manufacturer of the material recommends gas types of the group of M1, M2, M3 or C in **Table 2.2.37** and the test is satisfactorily conducted in accordance with the preceding (3) on one of the gas type, the test on the other gas types belonging to the same group is allowed to be dispensed with at the discretion of the Society.
- (6) The welding conditions used such as amperage, voltage, travel speed, etc. are to be within the range recommended by the manufacturer for normal good welding practice. Where a filler metal is stated to be suitable for both alternating current (AC) and direct current (DC), AC is to be used for the preparation of the test assemblies.
- (7) After welding, the test assemblies are not to be subjected to any heat treatment.

- (8) It is recommended that the welded assemblies be subjected to a radiographic examination to ascertain that there are any defects in the weld prior to the preparation of test specimens.

**Table 2.2.44 Kinds of Test for Semi-automatic Welding Consumables**

Kind of test <sup>(8)</sup>	Test assembly					Kinds and no. of test specimens taken from test assembly
	Welding position	Wire diameter (mm)	Number	Dimensions	Thickness (mm)	
Deposited metal test	Flat	maximum diameter	1 <sup>(1)</sup>	<b>Fig 2.2.22</b>	20	Tensile test specimen: 1 Impact test specimen: 3
		minimum diameter	1 <sup>(1)</sup>			
Butt weld test	Flat	First-run: minimum diameter Remaining-run: maximum diameter <sup>(4)</sup>	1 <sup>(2)</sup>	<b>Fig 2.2.24</b>	15~20	Tensile test specimen: 1 Face bend test specimen :1 Root bend test specimen: 1 Impact test specimen: 3 <sup>(3)</sup>
	Horizontal <sup>(5)</sup>		1			
	Vertical upward		1			
	Vertical downward		1			
	Overhead		1			
Fillet weld test <sup>(6)</sup>	Horizontal	One side: maximum diameter The other side: minimum diameter	1	<b>Fig 2.2.25</b>	20	Macro test specimen: 3 <sup>(7)</sup> Hardness test specimen: 3 <sup>(7)</sup> Fracture test specimen: 2

NOTES:

- (1) Where the core diameter to be manufactured is of single variety, the number of test assembly is to be one.
- (2) Where tests are conducted solely in the Flat position. one test assembly welded with wire of different diameters is to be added. Where only one diameter is manufactured, only one deposited metal assembly is to be prepared.
- (3) Impact tests are not required for welding in overhead position.
- (4) The butt weld assemblies in positions other than downhand, are to be welded using, for the first run, wire of the smallest diameter to be approved, and, for the remaining runs, the largest diameter of wire recommended by the manufacturer for the position concerned.
- (5) For semi-automatic welding consumables which have passed butt weld tests in the downhand and vertical upward positions, the horizontal butt weld test may be omitted. at the discretion of the Society.
- (6) This test is to be added solely against welding consumables for use in both butt and fillet weld.
- (7) The test specimens used in the macro-etching test and hardness test are to be the same.
- (8) For low hydrogen welding consumables, an hydrogen test may be conducted by the application of the manufacturer, and test assembly is to be as specified in **602. 6 (1)**.

**Table 2.2.45 Grades of Steel for Test Assembly (2017) (2021)**

Grade of welding consumables	Grade of steel for test assembly <sup>(1)(2)</sup>
1S	A
2S	A, B or D
3S	A, B, D or E
1YS	AH32 or AH36
2YS	AH32, AH36, DH32 or DH36
3YS	AH32, AH36, DH32, DH36, EH32 or EH36
4YS	AH32, AH36, DH32, DH36, EH32, EH36, FH32 or FH36
5YS	AH32, AH36, DH32, DH36, EH32, EH36, FH32 or FH36
2Y40S	AH40 or DH40
3Y40S	AH40, DH40 or EH40
4Y40S	AH40, DH40, EH40 or FH40
5Y40S	AH40, DH40, EH40 or FH40
3Y47S	EH47-H
L 1S	E or RL 235A
L 2S	E, RL 235A, RL 235B, RL 325A or RL 325B
L 3S	RL 325A, RL 325B or RL 355
L 51S	RL 5N390
L 91S	RL 9N490
<p>NOTES:</p> <p>(1) Notwithstanding the requirements in this Table, normal or higher strength steels may be used for deposited metal test assembly. In this case, test assemblies of grade L 91 are to be appropriately buttered.</p> <p>(2) The tensile strength of higher strength steels AH32, DH32, EH32 and FH32 used in butt weld test assemblies is to be greater than 490 N/mm<sup>2</sup>.</p>	

#### 4. Deposited metal test

##### (1) *Welding of Deposited metal test assemblies*

- (a) Test assembly as shown in **Fig 2.2.22** is to be welded in the flat position according to the normal practice.
- (b) Test assembly is to be welded in single or multi-run layers, and the direction of deposition of each run is to alternate from each end of the plate, each run of weld metal being not less than 2 mm but not more than 6 mm thick.
- (c) After each run, the test assembly is to be left in still air until it has cooled to less than 25 °C but not below 100°C, the temperature being taken at the centre of the weld on the surface of seam.

##### (2) *Chemical analysis*

The chemical analysis of the deposited weld metal in each test assembly is to be supplied by the manufacturer and is to include the content of all significant alloying element.

##### (3) *Deposited metal tensile test*

- (a) The tensile test specimen, one from each test assembly, is to be machined to dimensions R14A test specimen as shown in **Table 2.2.1**, care being taken that the longitudinal axis coincides with the centre of weld and the mid-thickness of plates.
- (b) The tensile test specimen may be subjected to a temperature not exceeding 250°C for a period not exceeding 16 hours for hydrogen removal prior to testing.
- (c) The tensile strength, yield strength and elongation of each test specimen are to comply with

the requirements given in **Table 2.2.46**, where the upper limit of tensile strength is exceeded, special consideration will be given to the approval of the electrode, taking into consideration of the other mechanical properties shown in the test results and the chemical composition of deposited metal.

**Table 2.2.46 Tensile and Impact Test Requirements for Deposited Metal test (2017) (2021)**

Grade of welding consumables	Tensile strength (N/mm <sup>2</sup> )	Yield strength (N/mm <sup>2</sup> )	Elongation (%)	Impact test	
				Test temp. (°C)	Average absorbed energy (J)
1S	400 ~ 560	305 min.	22 min.	20	47 min.
2S				0	
3S				-20	
1YS	490 ~ 660	375 min.	22 min.	20	
2YS				0	
3YS				-20	
4YS				-40	
5YS				-60	
2Y40S	510 ~ 690	400 min.	22 min.	0	
3Y40S				-20	
4Y40S				-40	
5Y40S				-60	
3Y47S	570 ~ 720	460 min.	19 min.	-20	64 min.
L 1S	400 ~ 560	305 min.	22 min.	-40	34 min.
L 2S	440 ~ 610	345 min.	22 min.	-60	
L 3S	490 ~ 660	375 min.	21 min.	-60	
L 51S	530 min	375 min. <sup>(1)</sup>	25 min.	-120	27 min.
L 91S	590 min	375 min. <sup>(1)</sup>	25 min.	-196	27 min.

NOTE:  
(1) 0.2 % yield stress

(4) *Deposited metal impact tests*

- (a) One set of three impact test specimens, from each test assembly, are to be machined to dimensions charpy V-notch impact test specimens as shown in **Table 2.1.3**. The test specimen is to be cut with its longitudinal axis transverse to the direction of welding, and the test specimen is to coincide with the mid-thickness of the plate shown in **Fig 2.2.23**.
- (b) Test temperature and average absorbed energy are to comply with the requirements given in **Table 2.2.39**.
- (c) The notch is to be positioned in the centre of weld and is to be cut in the face of test specimens perpendicular to the surface of plate.
- (d) When the absorbed energy of two or more test specimens among a set of test specimens is less in value than the specified average absorbed energy or when the absorbed energy of a single test specimen is less in value than 70 % of the specified average absorbed energy, the test is considered to have failed.

**5. Butt weld test**

- (1) *Welding of butt weld test assemblies*



- (a) Test assembly as shown in **Fig 2.2.24** is to be welded in each welding position (flat, horizontal-vertical, vertical-upward, vertical-downward and overhead) which is recommended by the manufacturer.
- (b) After each run, the test assembly is to be left in still air until it has cooled to less than 25 0°C but not below 100°C, the temperature being taken at the centre of the weld on the surface of seam.
- (2) *Butt weld tensile tests*
- (a) The tensile test specimen is to be *R2A* test specimen shown in **Table 2.2.1** and the test specimen is to be taken from each test assembly.
- (b) The surface of weld is to be machined flush with the surface of plate.
- (c) The tensile strength of test specimen is to comply with the requirements given in **Table 2.2.47**.

**Table 2.2.47 Tensile and Impact Test Requirements for Butt weld test (2017) (2021)**

Grade of welding consumables	Tensile strength (N/mm <sup>2</sup> )	Impact test				
		Test temp. (°C)	Average absorbed energy (J)			
			Flat, Horizontal Overhead	Vertical upward, Vertical downward		
1S	400 min.	20	47 min.	34 min.		
2S		0				
3S		-20				
1YS	490 min.	20				
2YS		0				
3YS		-20				
4YS		-40				
5YS		-60				
2Y40S	510 min.	0			27 min.	39 min.
3Y40S		-20				
4Y40S		-40				
5Y40S		-60				
3Y47S	570 min.	-20	64 min.	64 min.		
L 1S	400 min.	-40	27 min.	27 min.		
L 2S	440 min.	-60				
L 3S	490 min.	-60				
L 51S	530 min.	-120				
L 91S	630 min.	-196				

- (3) *Butt weld bend test*
- (a) The face and root bend test specimens are to be RB4 specimen shown in **Table 2.2.2**, and test specimens are to be taken from each test assembly. However, for *L 91*, the face and root bend specimens are to be RB1 specimen shown in **Table 2.2.2**, and test specimens are to be taken longitudinally from each test assembly. (2017)
- (b) The test specimens are to be capable of withstanding, without crack exceeding 3 mm long on the outer surface of other defects, being bent through an angle of 120 degrees over a former having a radius of 1.5 times (2 times for 3Y47) the thickness of test specimen. The radius and angle of the former for *L 91*, however, are to be 2 times the thickness of the specimen and 180 degrees respectively. (2017) (2021)

(4) *Butt weld impact test*

- (a) One set of three impact test specimens, from each test assembly, are to be machined to dimensions charpy V-notch impact test specimens as shown in **Table 2.1.3**. The test specimen is to be cut with its longitudinal axis transverse to the direction of welding, and the test specimen is to coincide with the mid-thickness of the plate shown in **Fig 2.2.23**.
- (b) Test temperature and average absorbed energy are to comply with the requirements given in **Table 2.2.47**.
- (c) The requirements in **Par 4** (4), (c) and (d) are to correspondingly apply to this Paragraph.

**6. Fillet weld test assemblies**

- (1) *Welding of fillet weld test assemblies* The test assemblies are to be in accordance with the requirements in **602. 7** (1).
- (2) *Fillet weld macro-structure test* The macro-structure test is to be correspondingly in accordance with the requirements in **602. 7** (2).
- (3) *Fillet weld hardness test* The hardness test is to be correspondingly in accordance with the requirements in **602. 7** (3).
- (4) *Fillet weld fracture test* The fracture test is to be correspondingly in accordance with the requirements in **602. 7** (4).

**7. Hydrogen test**

Flux-cored or flux-coated wires which have satisfied the requirements for Grades 2S, 2YS, 2Y40S, 3S, 3YS, 3Y40S, 4YS or 4Y40S may, at manufacturer's option, be submitted to the hydrogen test as detailed in **602. 6** using the manufacturer's recommended welding conditions and adjusting the deposition rate to give a weight of weld deposit per sample similar to that deposited when using manual electrodes.

**8. Annual inspections**

- (1) In the annual inspections, tests specified in the following (2) are to be conducted for each brand of the approved consumables, and they are to be passed satisfactorily.
- (2) The kinds of test, etc. in the annual inspection are to be as given in **Table 2.2.48**.

**Table 2.2.48 Kind of Test for Annual Inspection**

Kind of test	Test assembly					Kind and no. of test specimens taken from test assembly
	Welding position	Diameter of wire (mm)	Number	Dimension	Thickness (mm)	
Deposited metal test	Flat	(1)	1	<b>Fig 2.2.22</b>	20	Tensile test specimen : 1 Impact test specimen : 3
NOTE: (1) The diameters of the wire are to be within the range specified by the manufacturers.						

- (3) The welding procedures and requirements for test assemblies of tests specified in the preceding (2) are to be as specified in **Par 4**.

**9. Changes in grades**

- (1) Where changes in the grades relating to the strength or toughness or hydrogen of welding consumables approved are to be made, tests specified in the following (2), (3) and (4) are to be carried out and satisfactorily passed in accordance with the requirements in **601. 6** (3). (2017)
- (2) For changes in the grades relating to strength, the butt weld tests, specified in the annual inspection of **Par 8** and in the requirements of **Par 3** (1), are to be conducted.
- (3) For changes in the grades relating to toughness, the butt weld impact tests, specified in the annual inspection of **Par 8** and in the requirements of **Par 3** (1), are to be conducted.
- (4) For uprating of hydrogen, the hydrogen test, specified in the annual inspection of **Par 8** and in the requirements of **Par 3** (1), are to be conducted. (2017)

## 605. Electro-slag and electro-gas welding consumables

### 1. Application

Electro-slag and electro-gas welding consumables for normal strength and higher strength steels (hereinafter referred to as "welding consumables") are to be in accordance with the requirements in 605.

### 2. Grades and marks

Welding consumables are classified as specified in **Table 2.2.49**.

**Table 2.2.49 Grades and Marks (2021)**

For normal strength steel	For higher strength steel
1V, 2V, 3V	1YV, 2YV, 3YV, 4YV, 5YV 2Y40V, 3Y40V, 4Y40V, 5Y40V, 3Y47V

### 3. General provisions for tests

(1) Kinds of test, number, thickness and dimensions of test assemblies, grades and number of test specimens to be taken from each test assembly for welding consumables are to be as given in **Table 2.2.50**.

**Table 2.2.50 Kinds of Test for Electro-Slag and Electro-Gas Welding Consumables**

Kind of test	Test assembly <sup>(1)</sup>			Kinds and no. of test specimens taken from test assembly
	Number	Dimensions	Thickness (mm) <sup>(2)</sup>	
Butt weld test	1	Fig 2.2.33	20 ~ 25	Tensile test specimen: 2 Longitudinal tensile test specimen: 2 Side bend test specimen: 2 Impact test specimen: 6 Macro structure test specimen: 2
	1		35 ~ 40	
NOTE:				
(1) Where approval is requested for welding of both normal strength and higher strength steel two assemblies are to be prepared using higher strength steel. Two assemblies prepared using normal strength steel may also be required at the discretion of the Society.				
(2) Where thickness is restricted by welding process, thickness of test assemblies may be changed upon approval of the Society. In this case, the maximum test thickness is to be taken as the maximum applicable thickness.				

(2) Steel plates to be used for test assemblies are to be as given in **Table 2.2.51**, appropriate to the kind of welding consumables.

(3) For the approval of welding consumables, the tests specified in the preceding (1) are to be conducted for each brand of welding consumables.

(4) The welding conditions used such as amperage, voltage, travel speed, etc. are to be within the range recommended by the manufacturer for normal good welding practice. Where a filler metal is stated to be suitable for both alternating current (AC) and direct current (DC), AC is to be used for the preparation of the test assemblies.

(5) After welding, the test assemblies are not to be subjected to any heat treatment.

(6) It is recommended that the welded assemblies be subjected to a radiographic examination to ascertain that there are any defects in the weld prior to the preparation of test specimens.

Table 2.2.51 Grades of Steel used for Test Assembly (2021)

Grade of welding material	Grade of steel used for test assembly <sup>(1)(2)</sup>
1V	A
2V	A, B or D
3V	A, B, D or E
1YV	AH32 or AH36
2YV	AH32, AH36, DH32 or DH 36
3YV	AH32, AH36, DH 32, DH36, EH32 or EH36
4YV	AH32, AH36, DH32, DH36, EH32, EH36, FH32 or FH36
5YV	AH32, AH36, DH32, DH36, EH32, EH36, FH32 or FH36
2Y40V	AH40 or DH40
3Y40V	AH40, DH40 or EH40
4Y40V	AH40, DH40, EH40 or FH40
5Y40V	AH40, DH40, EH40 or FH40
3Y47V	EH47-H

NOTE:  
 (1) The tensile strength of higher strength steels of AH32, DH32, EH32 and FH32 used in the test assemblies is to be greater than 490 N/mm<sup>2</sup>.  
 (2) This is in respect of the content of grain refining elements, and if general approval is required, a niobium treated steel is to be used for the approval tests.

4. Butt weld test

(1) Welding of butt weld test assemblies

(a) Test assemblies as shown in Fig 2.2.33 are to be welded upward in vertical position in one Pass.

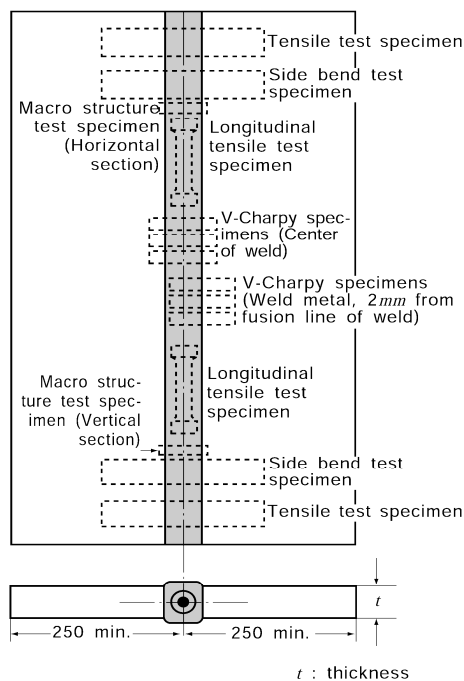


Fig 2.2.33 Butt Weld Assembly (Electro-slag and electrode-gas welding, Unit : mm)

- (b) The welding conditions and edge preparation are to be within the range recommended by the manufacturer.
- (2) *Tensile test*
- (a) Two tensile test specimens to be R2A specimen and two longitudinal tensile test specimens to be R14A specimen as shown in **Table 2.2.1** are to be taken from each test assembly. The longitudinal axis of test specimen coincides with the centre of weld and the mid-thickness of plates.
- (b) The longitudinal tensile test specimens may be subjected to the heat treatment not exceeding 250°C for a period not exceeding 16 hours for hydrogen removal prior to testing.
- (c) Tensile strength of each test specimen R2A and tensile strength, yield strength and elongation of each longitudinal test specimen R14A are to comply with the requirements in **Table 2.2.52**. Where the upper limit of tensile strength is exceeded, special consideration will be given to the approval of the welding consumables, taking into consideration of the other mechanical properties shown in the test results and chemical composition of deposited metal.

**Table 2.2.52 Tensile and Impact Test Requirements for Butt weld test (2021)**

Grade of welding consumables	Tensile strength (N/mm <sup>2</sup> )	Longitudinal Tensile Test			Impact test	
		Tensile strength (N/mm <sup>2</sup> )	Yield strength (N/mm <sup>2</sup> )	Elongation (%)	Test temp. (°C)	Average absorbed energy (J)
1V	400 min.	400 ~ 560	305 min.	22 min.	20	34 min.
2V					0	
3V					-20	
1YV	490 min.	490 ~ 660	375 min.	22 min.	20	
2YV					0	
3YV					-20	
4YV					-40	
5YV					-60	
2Y40V	510 min.	510 ~ 690	400 min.	22 min.	0	39 min.
3Y40V					-20	
4Y40V					-40	
5Y40V					-60	
3Y47V	570 min.	570 ~ 720	460 min.	19 min.	-20	64 min.

- (3) *Bend test*
- (a) Bend test specimens are to be RB6 specimens shown in **Table 2.2.2** and two side bend test specimens are to be taken from each test assembly.
- (b) The test specimens are to be capable of withstanding, without crack exceeding 3 mm long on the outer surface of other defects, being bent through an angle of 180 degrees over a former having a radius of two times the thickness of test specimen.
- (4) *Impact test*
- (a) Two sets of six impact test specimens, from each test assembly, are to be machined to dimensions Charpy V-notch impact test specimens as shown in **Table 2.1.3** and the longitudinal direction of the test specimen is to be perpendicular to the weld line and the surface of weld about 2 mm apart is to coincide with the surface of specimen as shown in **Fig 2.2.34**.
- (b) The position of the notch is to be in accordance with **Fig 2.2.34** (a) and (b) respectively, and its longitudinal direction is to be perpendicular to the surface of the test assembly.

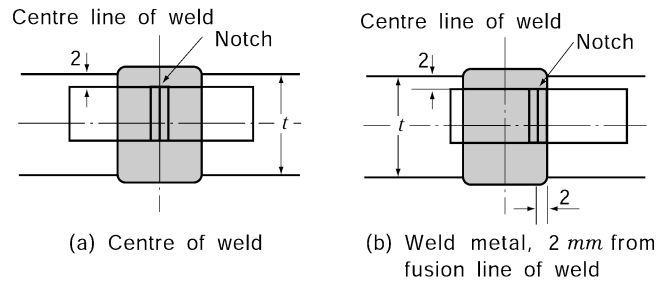


Fig 2.2.34 Position of Impact Specimen (Unit : mm, t = Plate thickness)

- (c) Test temperature and average absorbed energy are to comply with the requirements given in **Table 2.2.52**.
- (d) When the absorbed energy of two or more test specimens among a set of test specimens is less in value than the specified average absorbed energy or when the absorbed energy of a single test specimen is less in value than 70 % of the specified average absorbed energy, the test is considered to have failed.
- (5) *Macro-structure test*
  - (a) Two macro-structure test specimens are to be taken from the position shown in **Fig 2.2.33**. As for the surface to be tested, one is to be normal to the assembly surface and the other parallel to the assembly surface.
  - (b) Both the welded parts and the weld boundaries are to show complete fusion, penetration and sound metallurgical structure.

#### 5. Annual inspections

- (1) In the annual inspection, tests specified in the following (2) are to be conducted for each brand of the approved materials, and they are to be passed satisfactorily.
- (2) The kinds of test, etc. in the annual inspections are to be as given in **Table 2.2.53**.
- (3) The welding procedures and requirements for test assemblies of tests specified in the preceding (2) are to be as specified in **Par 4**.

Table 2.2.53 Kind of Test for Annual Inspection

Kind of test	Test assembly			Kinds and no. of test specimens taken from test assembly
	Number	Dimensions	Thickness (mm) <sup>(1)</sup>	
Butt weld test	1	<b>Fig 2.2.33</b>	20 ~ 25	Tensile test specimen: 1 Longitudinal Tensile test specimen: 1 Side bend test specimen: 2 Impact test specimen: 6 <sup>(1)</sup>
NOTE:				
(1) One set of three impact test specimens may be taken from the centre of welded part. where approved by the Society.				

#### 6. Changes in grades

Where changes in the grades relating to the strength or toughness of welding consumables approved are to be made, tests specified in **Par 3** (1) are to be conducted and satisfactorily passed in accordance with the requirements in **601. 6** (3).

**606. One side welding consumables for normal strength steels, higher strength steels and steels for low temperature service.**

**1. Application**

- (1) Welding consumables for normal strength steels, higher strength steels and steels for low temperature service given in the following (a) through (c) (hereinafter referred to as "one side automatic welding consumables") are to be subjected to the approval tests and annual inspections in accordance with the requirements in **606**.
  - (a) Submerged arc one side automatic welding consumables
  - (b) Gas shielded arc one side automatic welding consumables (solid wire or flux cored wire with shielding gas)
  - (c) Self-shielded arc one side automatic welding consumables (flux cored wire or flux coated wire without shielding gas)
- (2) Approval tests and annual inspections of one side covered electrodes for normal strength steels, higher strength steels and steels for low temperature service, and one side semi-automatic welding consumables are to be as deemed appropriate by the Society. **【See Guidance】**
- (3) Approval tests and annual inspections for one side automatic welding consumables of multiple electrodes are to be as deemed appropriate by the Society. **【See Guidance】**

**2. Grades and marks**

- (1) One side automatic welding consumables are classified as specified in **603. 2**. Further, one side automatic welding consumables which have passed the tests for each welding procedure given in **Table 2.2.55** are to be appended with the suffixes given in **Table 2.2.54** at the end of their marks.
- (2) In the preceding (1), a suffix G will be added to the grade mark for gas shielded arc one side automatic welding consumables, and a suffix N will be added for self-shielded wire one side automatic welding consumables. Further, the type of gas used is to be as specified in **Table 2.2.37** and the suffix given in **Table 2.2.37** will be added after the suffix G. (e.g. 3Y *SMR G(M1)*)

**Table 2.2.54 Marks**

Welding technique <sup>(1)</sup>	Marks
One-run technique	<i>SR</i>
Multi-run technique	<i>MR</i>
One-run and multi-run technique	<i>SMR</i>
NOTE:	
(1) One-run or multi-run technique refers to a welding process which performed in one pass or multiple passes respectively regardless of the number of electrodes.	

**3. General provisions for tests**

- (1) Kinds of test, number, thickness and dimensions of test assemblies, grades and number of test specimens to be taken from each test assembly for one side automatic welding consumables are to be as given in **Table 2.2.55**.
- (2) Steel plates to be used for test assemblies are to be as given in **Table 2.2.56**.
- (3) For the approval of one side automatic welding consumables, the tests specified in the preceding (1) are to be conducted for each brand of one side automatic welding consumables.
- (4) For gas shield arc one side automatic welding consumables, the test in the preceding (3) is to be performed for each type of gas given in **Table 2.2.37**. When the manufacturer of the material recommends gas types of the group of *M1*, *M2*, *M3* or *C* in **Table 2.2.37** and the test is satisfactorily conducted in accordance with the preceding (3) on one of the gas type, the test on the other gas types belonging to the same group is allowed to be dispensed with at the discretion of the Society.

Table 2.2.55 Kinds of Test for One-side Automatic Welding Consumables (2017) (2021)

Grade of welding consumables	Welding technique	Kind of test <sup>(4)</sup>	Test assembly			Kind and number of test specimens taken from test assembly
			Number	Thickness (mm) <sup>(1)</sup>	Dimension	
1, 2, 3, 1Y, 2Y, 3Y, 4Y, 5Y, 2Y40, 3Y40, 4Y40, 5Y40, 3Y47 L1, L2, L3, L51, L91	One-run technique	Butt weld test	1	12 ~ 15	Fig 2.2.35	Tensile test specimen: 2 Longitudinal tensile test specimen: 1 Face bend specimen: 1 Root bend specimen: 1 Impact test specimen: 6 Macro-structure test specimen: 1
			1	Maximum thickness		
	Multi-run technique		1	15 ~ 25		
			1	35		
	One-run and Multi-run technique		1	Maximum thickness <sup>(2)</sup>		
			1	35 <sup>(3)</sup>		

NOTES:

(1) Where thickness is restricted by welding process, thickness of test assemblies may be changed upon approval of the Society. In this case, the maximum test thickness is to be taken as the maximum applicable thickness.

(2) Thickness of test assembly for one run technique.

(3) Thickness of test assembly for multi-run technique.

(4) The hydrogen test may be carried out according to the manufacturer's request.



**Table 2.2.56 Grades of Steel used for Test Assembly (2017) (2021)**

Grade of welding consumables	Grade of steel used for test assembly <sup>(1)</sup>
1	A
2	A, B or D
3	A, B, D or E
1Y	AH32 or AH36
2Y	AH32, AH36, DH32 or DH36
3Y	AH32, AH36, DH32, DH36, EH32 or EH36
4Y	AH32, AH36, DH32, DH36, EH32, EH36, FH32 or FH36
5Y	AH32, AH36, DH32, DH36, EH32, EH36, FH32 or FH36
2Y40	AH40 or DH40
3Y40	AH40, DH40 or EH40
4Y40	AH40, DH40, EH40 or FH40
5Y40	AH40, DH40, EH40 or FH40
3Y47	EH47-H
L1	E or RL235A
L2	E, RL235A, RL235B, RL325A or RL325B
L3	RL325A, RL325B or RL355
L51	RL5N390
L91	RL9N490
NOTE: (1) The tensile strength of higher strength steels AH32, DH32, EH32 and FH32 used in the test assemblies is to be greater than 490 N/mm <sup>2</sup>	

- (5) The combination of one side automatic welding materials are classified as given in **Table 2.2.57**, appropriate to the welding procedure.

**Table 2.2.57 Combinations of One Side Automatic Welding Consumables**

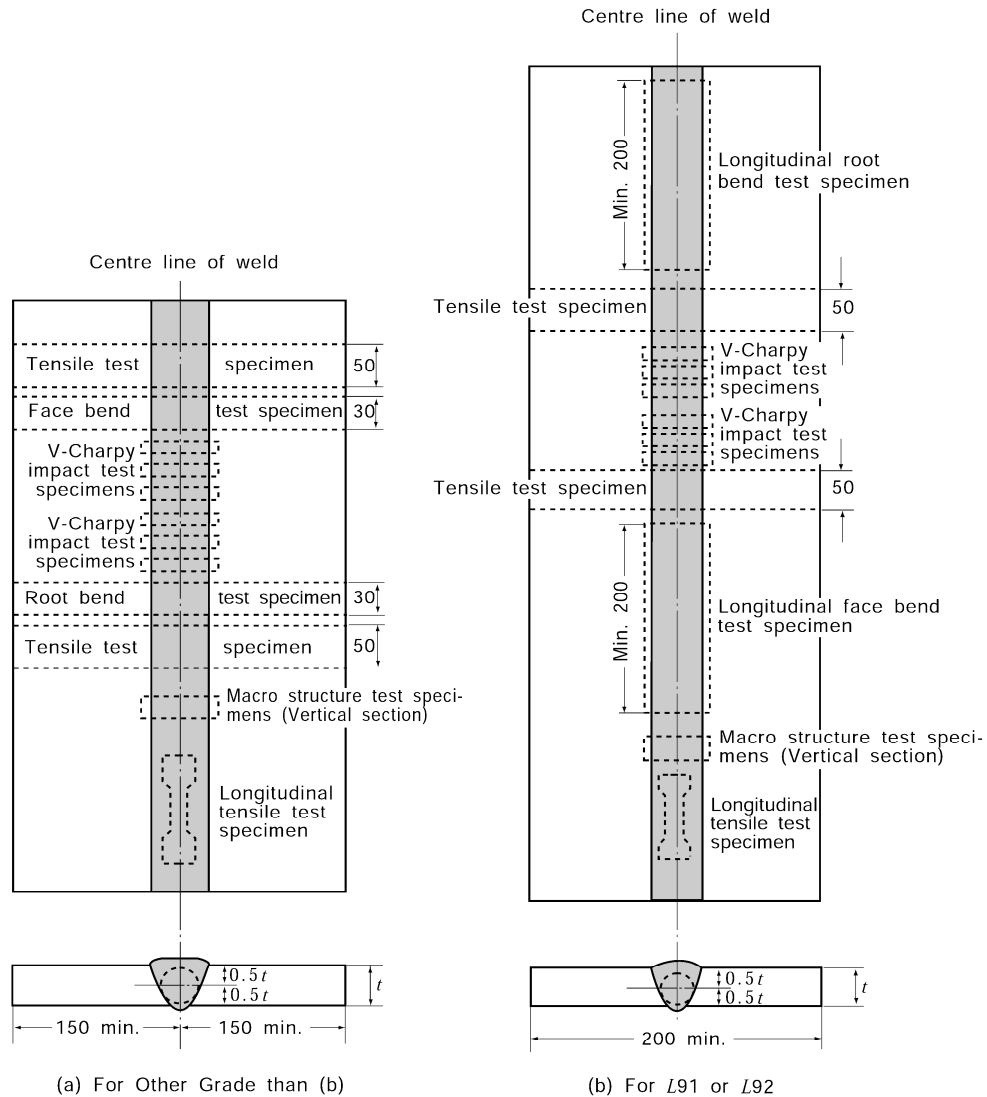
Welding technique	Combinations of welding consumables
Submerged one side automatic welding	Wire + Flux + Iron powder + Backing
Gas shielded arc one side automatic welding	Wire + Gas + Iron powder + Backing
Self-shielded arc one side automatic welding	Wire + Iron powder + Backing
NOTE: Where iron powder is not used, iron powder is excluded in this Table.	

- (6) The welding conditions used such as amperage, voltage, travel speed, etc. are to be within the range recommended by the manufacturer for normal good welding practice. Where a filler metal is stated to be suitable for both alternating current (AC) and direct current (DC), AC is to be used for the preparation of the test assemblies.
- (7) After welding, the test assemblies are not to be subjected to any heat treatment.
- (8) It is recommended that the welded assemblies be subjected to a radiographic examination to ascertain that there are any defects in the weld prior to the preparation of test specimens.

#### 4. Butt weld test assemblies with one-run and multi-run technique

(1) *Welding of butt weld test assemblies with one-run and multi-run technique*

- (a) Test assemblies are to be prepared as shown in **Fig 2.2.35**, and the diameter of wire, root gap and edge preparation are to be within the range specified by the manufacturer.



**Fig 2.2.35** Butt Weld Test Assembly with One-run and Multi-run Technique (Unit : mm,  $t$ = Plate thickness)

- (b) Test assemblies are to be welded in downhand position by one-run technique or multi-run technique according to the procedures specified by the manufacturer. However, for gas shield and self-shielded arc one side automatic welding consumables, the welding position is to be specified by the manufacturer.
- (c) After completing each run the test assembly is to be left in still air until it has cooled to less than 250°C but not below 100°C, the temperature being taken at the centre of weld on the surface of seam.
- (2) *Butt weld tensile test with one-run and multi-run technique*
- (a) Two tensile test specimens to be *R2A* specimen and one longitudinal tensile test specimen to be *R14A* specimen as shown in **Table 2.2.1** are to be taken from each test assembly. The longitudinal axis of test specimen coincides with the centre of weld and the mid-thickness of plate.
- (b) The longitudinal tensile test specimen may be subjected to a temperature not exceeding 25 0°C for a period not exceeding 16 hours for hydrogen removal prior to testing.

- (c) Tensile strength of each test specimen  $R2A$  is to comply with the requirements in **Table 2.2.41**. Tensile strength, yield strength and elongation of longitudinal tensile test specimens  $R14$  are to comply with the requirements given in **Table 2.2.40**. Where the upper limit of tensile strength is exceeded, special consideration will be given to the approval of the welding consumables, taking into consideration of the other mechanical properties shown in the test results and chemical composition of deposited metal.
- (3) *Butt weld bend test with one-run and multi-run technique* The bend tests are to comply with the requirements in **603. 6. (4)**.
- (4) *Butt weld impact test with one-run and multi-run technique*
- (a) Two sets of impact test specimens, from each test assembly, are to be machined to dimensions  $R4$  test specimen as shown in **Table 2.1.3**. Longitudinal direction of the test specimen is to be perpendicular to the weld line as shown in **Fig 2.2.36**.
- (b) Test temperature and average absorbed energy are to comply with the requirements given in **Table 2.2.41**.

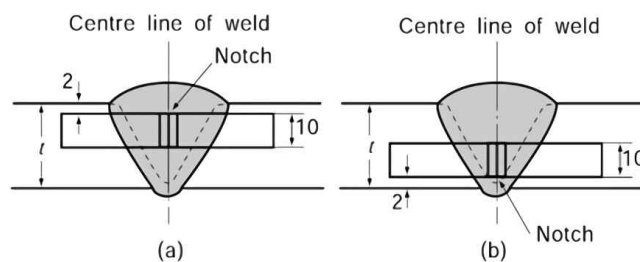


Fig 2.2.36 Position of Impact Test Specimen for Butt Weld with One-run and Multi-run Technique (Unit : mm,  $t$  = Plate thickness)

- (c) The notch is to be positioned in the centre of weld and is to be cut in the face of test specimens perpendicular to the surface of plate.
- (d) When the absorbed energy of two or more test specimens among a set of test specimens is less in value than the specified average absorbed energy or when the absorbed energy of a single test specimen is less in value than 70 % of the specified average absorbed energy, the test is considered to have failed.
- (5) *Butt weld macro-structure test with one-run and multirun technique*
- (a) Macro-structure test specimens are to be taken from the position shown in **Fig 2.2.35**. The surface to be tested is to be perpendicular to the surface of the test assembly.
- (b) Both the welded parts and the weld boundaries are to show complete fusion, penetration and sound metallurgical structure.

## 5. Hydrogen test

The hydrogen test is to be in accordance with **602. 6** of the Rules

## 6. Annual inspections

- (1) In the annual inspection, tests specified in the following (2) are to be conducted for each brand of the approved consumables, and they are to be passed satisfactorily.
- (2) The kinds of test, etc. in the annual inspection are to be as given in **Table 2.2.58**.

Table 2.2.58 Kinds of Test for Annual Inspection (2017) (2021)

Grade of welding consumables	Welding technique	Kind of test	Test assembly			Kind and number of test specimens taken from test assembly
			Number	Dimension	Thickness (mm) <sup>(1)</sup>	
1, 2, 3, 1Y, 2Y, 3Y, 4Y, 5Y, 2Y40, 3Y40, 4Y40, 5Y40, 3Y47, L1, L2, L3, L51, L91	One-run technique	Butt weld test <sup>(2)</sup>	1	Fig 2.2.35	20	Tensile test specimen: 1 Longitudinal tensile test specimen: 1 Face bend specimen: 1 Root bend specimen: 1 Impact test specimen: 3 <sup>(3)</sup>
	Multi-run technique		1		20~25	Tensile test specimen: 1 Longitudinal tensile test specimen: 1 Face bend specimen: 1 Root bend specimen: 1 Impact test specimen: 3 <sup>(3)</sup>
	One-run and Multi-run technique		1		20~25	Tensile test specimen: 1 Longitudinal tensile test specimen: 1 Face bend specimen: 1 Root bend specimen: 1 Impact test Specimen: 3 <sup>(3)</sup>
NOTES:						
(1) Where the thickness of test assemblies is changed according to Note (1) of Table 2.2.55, the maximum test thickness for approval test is to be applied.						
(2) The butt weld tests for one-run and multi-run technique are to be carried out by one-run technique.						
(3) The positions of notch and selection of impact test specimens are to be as given in Fig 2.2.36 (b).						

(3) The welding procedures and requirements of test assemblies for tests in the preceding (2) are to be as specified in Par 4.

### 7. Changes in grades

Where changes in the grades relating to the strength or toughness of one side automatic welding consumables approved are to be made, all the tests specified in Par 3 (1) are to be carried out and satisfactorily passed in accordance with the requirements in 601. 6 (3).

## 607. Welding consumables for stainless steel

### 1. Application

- (1) Welding consumables for stainless steels specified in Ch 1, Sec 3 (hereinafter referred to as "welding consumables") are to be subjected to the approval tests and annual inspections in accordance with the requirements in 607.
- (2) Welding consumables for duplex stainless steel is to be in accordance with the Guidance in relating to Rules. **[See Guidance]**

### 2. Grades and marks

- (1) Welding consumables are classified as specified in Table 2.2.59.
- (2) Submerged arc welding consumables which have passed the tests for each welding process given in Table 2.2.61 are to be appended with the suffixes shown in Table 2.2.60 at the end of their marks.
- (3) For flux cored wire semi-automatic welding consumables in the preceding (1), a suffix G will be added to the grade mark for welding consumables which use shield gas, and a suffix N will be added to the grade marks for welding consumables which do not used shield gas. Further, the type of shield gas used is to be as specified in Table 2.2.37 and the suffix given in Table 2.2.37 will be added after the suffix G. (e.g. RW308G (C))

**Table 2.2.59 Grades and Marks of Welding Consumables**

Electrode for manual arc welding	Material for TIG and MIG welding	Flux cored wire semi-automatic welding	Consumables for submerged welding
<i>RD 308</i>	<i>RY308</i>	<i>RW308</i>	<i>RU308</i>
<i>RD 308L</i>	<i>RY308L</i>	<i>RW308L</i>	<i>RU308L</i>
<i>RD 309</i>	<i>RY309</i>	<i>RW309</i>	<i>RU309</i>
<i>RD 309L</i>	<i>RY309L</i>	<i>RW309L</i>	-
<i>RD 309Mo</i>	<i>RY309Mo</i>	<i>RW309Mo</i>	<i>RU309Mo</i>
<i>RD 309MoL</i>	-	<i>RW309MoL</i>	-
<i>RD 310</i>	<i>RY310</i>	<i>RW310</i>	<i>RU310</i>
-	<i>RY310S</i>	-	-
<i>RD 310Mo</i>	-	-	-
<i>RD 316</i>	<i>RY316</i>	<i>RW316</i>	<i>RU316</i>
<i>RD 316L</i>	<i>RY316L</i>	<i>RW316L</i>	<i>RU316L</i>
<i>RD 317</i>	<i>RY317</i>	<i>RW317</i>	<i>RU317</i>
<i>RD 317L</i>	<i>RY317L</i>	<i>RW317L</i>	<i>RU317L</i>
-	<i>RY321</i>	-	-
<i>RD 347</i>	<i>RY347</i>	<i>RW347</i>	<i>RU347</i>

**Table 2.2.60 Marks**

Welding technique	Marks
Multi-run technique	<i>M</i>
Two-run technique	<i>T</i>
Multi-run and Two-run technique	<i>TM</i>

### 3. General provisions for tests

- (1) Kinds of test, number, thickness and dimensions of test assemblies, diameter of wire used for welding, grades and number of test specimens to be taken from each test assembly in each welding position for welding consumables are to be as given in **Table 2.2.61**. However, additional tests appropriate to steels, such as test on corrosion-resistance test, impact test, macro etching test, etc., except the test given in **Table 2.2.61** may be required where deemed necessary by the Society. **[See Guidance]**
- (2) Steel plates to be used for test assemblies are to be as given in **Table 2.2.62** according to the grades of welding consumables, or other materials recognized by the Society may be used. (2020)
- (3) For the approval of welding consumables, the tests specified in the preceding (1) are to be conducted for each brand of welding consumables.
- (4) For flux cored wire semi-automatic welding materials, which use shield gas, the test in the preceding (3) is to be performed for each type of gas given in **Table 2.2.37**. When the manufacturer of the consumables recommends gas types of the group of *M1*, *M2*, *M3* or *C* in **Table 2.2.37** and the test is satisfactorily conducted in accordance with the preceding (3) on one of the gas type, the test on the other gas types belonging to the same group is allowed to be dispensed with at the discretion of the Society.
- (5) The welding conditions used such as amperage, voltage, travel speed, etc. are to be within the range recommended by the manufacturer for normal good welding practice. Where a filler metal is stated to be suitable for both alternating current (AC) and direct current (DC), AC is to be used for the preparation of the test assemblies.

Table 2.2.61 Kinds of Test of Welding Consumables for Stainless Steel

Kind of welding consumables	Kind of test	Test assembly					Kind and number of test specimens taken from test assembly	
		Thick-ness (mm)	No.	Welding position	Dia. of electrode or wire <sup>(1)</sup> (mm)	Dimension		
Electrode for manual arc welding	Deposited metal test	12	1	Flat	3.2	Fig 2.2.37	Tensile test specimen: 1	
		20	1		4.0			
	Butt weld test	15~20	1	1	Flat	3.2 or 4.0	Fig 2.2.38	Tensile test specimen: 1 Face bend Specimen: 1 Root bend specimen: 1
					Horizontal			
					Vertical upward			
					Vertical downward			
Overhead	1	1	1	Overhead	2.0~3.2	Fig 2.2.38	Tensile test specimen: 1 Face bend specimen: 1 Root bend specimen: 1	
				Horizontal				
				Vertical upward				
				Vertical downward				
				Overhead				
Consumables for TIG welding	Deposited metal test	12	1	Flat	2.4	Fig 2.2.37	Tensile test specimen: 1	
		20	1		3.2			
	Butt weld test	15~20	1	1	Flat	2.0~3.2	Fig 2.2.38	Tensile test specimen: 1 Face bend specimen: 1 Root bend specimen: 1
					Horizontal			
					Vertical upward			
					Vertical downward			
Overhead	1	1	1	Overhead	1.2~2.0	Fig 2.2.38	Tensile test specimen: 1 Face bend specimen: 1 Root bend specimen: 1	
				Horizontal				
				Vertical upward				
				Vertical downward				
				Overhead				
Consumables for MIG welding	Deposited metal test	12	1	Flat	1.2	Fig 2.2.37	Tensile test specimen: 1	
		20	1		1.6			
	Butt weld test	15~20	1	1	Flat	1.2~2.0	Fig 2.2.38	Tensile test specimen: 1 Face bend specimen: 1 Root bend specimen: 1
					Horizontal			
					Vertical upward			
					Vertical downward			
Overhead	1	1	1	Overhead	1.2~2.4	Fig 2.2.37	Tensile test specimen: 1	
				Horizontal				
				Vertical upward				
				Vertical downward				
				Overhead				
Flux cored wire for semi-automatic welding	Deposited metal test	12	1	Flat	1.2~2.4	Fig 2.2.37	Tensile test specimen: 1	
		20	1		3.2 or max. dia			
	Butt weld test	15~20	1	1	Flat	1.2~3.2	Fig 2.2.38	Tensile test specimen: 1 Face bend specimen: 1 Root bend specimen: 1
					Horizontal			
					Vertical upward			
					Vertical downward			
Overhead	1	1	1	Overhead	1.2~4.0	Fig 2.2.37	Tensile test specimen: 1	
				Horizontal				
				Vertical upward				
				Vertical downward				
				Overhead				
Consumables for submerged arc welding <sup>(2)</sup>	Multi-run technique	Deposited metal test	19~25	1	Flat	1.2~4.0	Fig 2.2.37	Tensile test specimen: 1
	Two-run technique	Butt weld test	12	1	Flat	1.2~2.4	Fig 2.2.39 (b)	Tensile test specimen: 1 Face bend specimen: 1 Root bend specimen: 1
			19	1	Flat	4.0		

NOTES:

- (1) Where approved by the Society, the diameter of electrodes or wires may be changed.
- (2) Tests on both multi-run and two run technique are to be conducted for multi-run and two run welding respectively and the number, dimensions and thickness of test assemblies, along with the grades and number of test specimens selected from each test assembly are to be according to each of the welding processes. However, longitudinal tensile test of two run technique are not required.

**Table 2.2.62 Grades of Steel for Test Assembly**

Grade of welding consumables	Grade of steel for test assembly <sup>(1)</sup>
<i>RD 308, RY308, RW308, RU 308</i>	<i>RSTS304</i>
<i>RD 308L, RY308L, RW308L, RU308L</i>	<i>RSTS304L</i>
<i>RD 309, RY309, RW309, RU 309</i>	<i>RSTS309S</i>
<i>RD 309L, RY309L, RW309L</i>	
<i>RD 309Mo, RY309Mo, RW309Mo, RU 309Mo</i>	
<i>RD 309MoL, RW309MoL</i>	<i>RSTS310S</i>
<i>RD 310, RY310, RW310, RU 310</i>	
<i>RY310S</i>	
<i>RD 310Mo</i>	<i>RSTS316</i>
<i>RD 316, RY316, RW316, RU 316</i>	
<i>RD 316L, RY316L, RW316L, RU316L</i>	<i>RSTS316L</i>
<i>RD 317, RY317, RW317, RU 317</i>	<i>RSTS317</i>
<i>RD 317L, RY317L, RW317L, RU317L</i>	<i>RSTS317, RSTS317L</i>
<i>RY321</i>	<i>RSTS321</i>
<i>RD 347, RY347, RW347, RU 347</i>	<i>RSTS321, RSTS347</i>
NOTE: (1) Notwithstanding the requirements in this table, mild steel or higher strength steel may be used for deposited metal test assembly. In this case, test assemblies are to be appropriately buttered.	

- (6) After welding, the test assemblies are not to be subjected to any heat treatment.  
(7) It is recommended that the welded assemblies be subjected to a radiographic examination to ascertain that there are any defects in the weld prior to the preparation of test specimens.

#### 4. Deposited metal test

- (1) *Welding of deposited metal test assemblies*  
(a) Test assemblies as shown in **Fig 2.2.37** are to be welded in the flat position according to the welding procedure recommended by the manufacturer.  
(b) After each run, the test assembly is to be left in still air until it has cooled to less than 15 0°C but not below 15°C, the temperature being taken at the centre of the weld on the surface of seam.
- (2) *Chemical composition*  
(a) Deposited metals of electrodes for manual arc welding and of welding consumables for flux cored wire semi-automatic welding and submerged arc welding are to have the chemical composition given in **Tables 2.2.63, 2.2.65 and 2.2.66** respectively.  
(b) TIG and MIG welding consumables are to have the chemical composition of ladle analysis value complied with the requirements as given in **Table 2.2.64**.
- (3) *Deposited metal tensile test*  
(a) One tensile test specimens to be R10 shown in **Table 2.2.1** is to be taken from each test assembly. Further, where approved by the Society, one R14A tensile test specimen may be taken, the longitudinal axis of test specimen coincides with the centre of weld and the mid-thickness of plate.  
(b) The tensile test specimens may be subjected to a temperature not exceeding 250°C for a period not exceeding 16 hours for hydrogen removal prior to testing.  
(c) Deposited metal tensile tests are to comply with the requirements in **Table 2.2.67**.

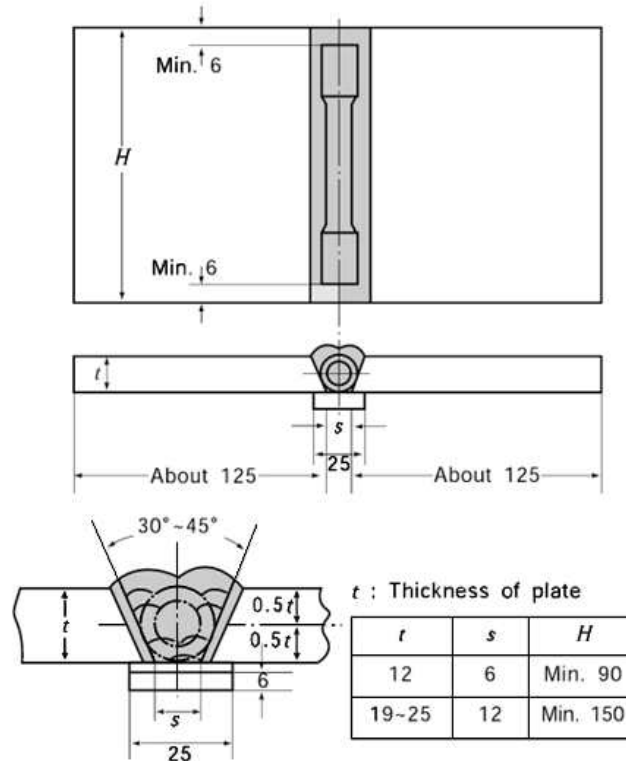


Fig 2.2.37 Deposited Metal Test Assembly for Stainless Steel (Unit : mm)

Table 2.2.63 Chemical Composition of Deposited Metal for Electrodes

Grade	Chemical composition (%)								
	C(max.)	Si(max.)	Mn(max.)	P(max.)	S(max.)	Ni	Cr	Mo	Others
RD 308	0.08	0.90	2.50	0.04	0.03	9.0 ~ 11.0	18.0 ~ 21.0	-	-
RD 308L	0.04	0.90	2.50	0.04	0.03	9.0 ~ 12.0	18.0 ~ 21.0	-	-
RD 309	0.15	0.90	2.50	0.04	0.03	12.0 ~ 14.0	22.0 ~ 25.0	-	-
RD 309L	0.04	0.90	2.50	0.04	0.03	12.0 ~ 16.0	22.0 ~ 25.0	-	-
RD 309Mo	0.12	0.90	2.50	0.04	0.03	12.0 ~ 14.0	22.0 ~ 25.0	2.0 ~ 3.0	-
RD 309MoL	0.04	0.90	2.50	0.04	0.03	12.0 ~ 14.0	22.0 ~ 25.0	2.0 ~ 3.0	-
RD 310	0.20	0.75	2.50	0.03	0.03	20.0 ~ 22.0	25.0 ~ 28.0	-	-
RD 310Mo	0.12	0.75	2.50	0.03	0.03	20.0 ~ 22.0	25.0 ~ 28.0	2.0 ~ 3.0	-
RD 316	0.08	0.90	2.50	0.04	0.03	11.0 ~ 14.0	17.0 ~ 20.0	2.0 ~ 2.75	-
RD 316L	0.04	0.90	2.50	0.04	0.03	11.0 ~ 16.0	17.0 ~ 20.0	2.0 ~ 2.75	-
RD 317	0.08	0.90	2.50	0.04	0.03	12.0 ~ 14.0	18.0 ~ 21.0	3.0 ~ 4.0	-
RD 317L	0.04	0.90	2.50	0.04	0.03	12.0 ~ 16.0	18.0 ~ 21.0	3.0 ~ 4.0	-
RD 347	0.08	0.90	2.50	0.04	0.03	9.0 ~ 11.0	18.0 ~ 21.0	-	Nb8×C (%)~1.0



Table 2.2.64 Chemical Composition of Deposited Metal for TIG Electrodes or MIG Wires

Grade	Chemical composition (%)								
	C(max.)	Si(max.)	Mn	P(max.)	S(max.)	Ni	Cr	Mo	Others
<i>RY308</i>	0.08	0.65	1.0 ~ 2.5	0.03	0.03	9.0 ~ 11.0	19.0 ~ 22.0	-	-
<i>RY308L</i>	0.03	0.65	1.0 ~ 2.5	0.03	0.03	9.0 ~ 11.0	19.0 ~ 22.0	-	-
<i>RY309</i>	0.12	0.65	1.0 ~ 2.5	0.03	0.03	12.0 ~ 14.0	23.0 ~ 25.0	-	-
<i>RY309L</i>	0.03	0.65	1.0 ~ 2.5	0.03	0.03	12.0 ~ 14.0	23.0 ~ 25.0	-	-
<i>RY309Mo</i>	0.12	0.65	1.0 ~ 2.5	0.03	0.03	12.0 ~ 14.0	23.0 ~ 25.0	2.0 ~ 3.0	-
<i>RY310</i>	0.15	0.65	1.0 ~ 2.5	0.03	0.03	20.0 ~ 22.5	25.0 ~ 28.0	-	-
<i>RY310S</i>	0.08	0.65	1.0 ~ 2.5	0.03	0.03	20.0 ~ 22.5	25.0 ~ 28.0	-	-
<i>RY316</i>	0.08	0.65	1.0 ~ 2.5	0.03	0.03	11.0 ~ 14.0	18.0 ~ 20.0	2.0 ~ 3.0	-
<i>RY316L</i>	0.03	0.65	1.0 ~ 2.5	0.03	0.03	11.0 ~ 14.0	18.0 ~ 20.0	2.0 ~ 3.0	-
<i>RY317</i>	0.08	0.65	1.0 ~ 2.5	0.03	0.03	13.0 ~ 15.0	18.5 ~ 20.5	3.0 ~ 4.0	-
<i>RY317L</i>	0.03	0.65	1.0 ~ 2.5	0.03	0.03	13.0 ~ 15.0	18.5 ~ 20.5	3.0 ~ 4.0	-
<i>RY321</i>	0.08	0.65	1.0 ~ 2.5	0.03	0.03	9.0 ~ 10.5	18.5 ~ 20.5	-	Ti9×C (%) ~ 1.0
<i>RY347</i>	0.08	0.65	1.0 ~ 2.5	0.03	0.03	9.0 ~ 11.0	19.0 ~ 21.5	-	Nb10×C (%) ~ 1.0

Table 2.2.65 Chemical Composition of Deposited Metal for Flux Cored Wire Semi-automatic Welding

(a) With Gas

Grade	Chemical composition (%)								
	C(max.)	Si(max.)	Mn	P(max.)	S(max.)	Ni	Cr	Mo	Others
<i>RW308</i>	0.08	1.0	0.5 ~ 2.5	0.04	0.03	9.0 ~ 11.0	18.0 ~ 21.0	-	-
<i>RW308L</i>	0.04	1.0	0.5 ~ 2.5	0.04	0.03	9.0 ~ 12.0	18.0 ~ 21.0	-	-
<i>RW309</i>	0.10	1.0	0.5 ~ 2.5	0.04	0.03	12.0 ~ 14.0	22.0 ~ 25.0	-	-
<i>RW309L</i>	0.04	1.0	0.5 ~ 2.5	0.04	0.03	12.0 ~ 14.0	22.0 ~ 25.0	-	-
<i>RW309Mo</i>	0.12	1.0	0.5 ~ 2.5	0.04	0.03	12.0 ~ 14.0	22.0 ~ 25.0	2.0 ~ 3.0	-
<i>RW309MoL</i>	0.04	1.0	0.5 ~ 2.5	0.04	0.03	12.0 ~ 14.0	22.0 ~ 25.0	2.0 ~ 3.0	-
<i>RW310</i>	0.20	1.0	0.5 ~ 2.5	0.04	0.03	20.0 ~ 22.0	25.0 ~ 28.0	-	-
<i>RW316</i>	0.08	1.0	0.5 ~ 2.5	0.04	0.03	11.0 ~ 14.0	17.0 ~ 20.0	2.0 ~ 3.0	-
<i>RW316L</i>	0.04	1.0	0.5 ~ 2.5	0.04	0.03	11.0 ~ 14.0	17.0 ~ 20.0	2.0 ~ 3.0	-
<i>RW317</i>	0.08	1.0	0.5 ~ 2.5	0.04	0.03	12.0 ~ 14.0	18.0 ~ 21.0	3.0 ~ 4.0	-
<i>RW317L</i>	0.04	1.0	0.5 ~ 2.5	0.04	0.03	12.0 ~ 16.0	18.0 ~ 21.0	3.0 ~ 4.0	-
<i>RW347</i>	0.08	1.0	0.5 ~ 2.5	0.04	0.03	9.0 ~ 11.0	18.0 ~ 21.0	-	Nb8×C (%) ~ 1.0

Table 2.2.65 Chemical Composition of Deposited Metal for Flux Cored Wire Semi-automatic Welding

(b) Without Gas

Grade	Chemical composition (%)								
	C(max.)	Si(max.)	Mn	P(max.)	S(max.)	Ni	Cr	Mo	Others
<i>RW308</i>	0.08	1.0	0.5 ~ 2.5	0.04	0.03	9.0 ~ 11.0	19.5 ~ 22.0	-	-
<i>RW308L</i>	0.04	1.0	0.5 ~ 2.5	0.04	0.03	9.0 ~ 12.0	19.5 ~ 22.0	-	-
<i>RW309</i>	0.10	1.0	0.5 ~ 2.5	0.04	0.03	12.0 ~ 14.0	23.0 ~ 25.5	-	-
<i>RW309L</i>	0.04	1.0	0.5 ~ 2.5	0.04	0.03	12.0 ~ 14.0	23.0 ~ 25.5	-	-
<i>RW309Mo</i>	0.12	1.0	0.5 ~ 2.5	0.04	0.03	12.0 ~ 14.0	22.0 ~ 25.0	2.0 ~ 3.0	-
<i>RW309MoL</i>	0.04	1.0	0.5 ~ 2.5	0.04	0.03	12.0 ~ 14.0	22.0 ~ 25.0	2.0 ~ 3.0	-
<i>RW310</i>	0.20	1.0	0.5 ~ 2.5	0.04	0.03	20.0 ~ 22.0	25.0 ~ 28.0	-	-
<i>RW316</i>	0.08	1.0	0.5 ~ 2.5	0.04	0.03	11.0 ~ 14.0	18.0 ~ 20.5	2.0 ~ 3.0	-
<i>RW316L</i>	0.04	1.0	0.5 ~ 2.5	0.04	0.03	11.0 ~ 14.0	18.0 ~ 20.5	2.0 ~ 3.0	-
<i>RW317</i>	0.08	1.0	0.5 ~ 2.5	0.04	0.03	13.0 ~ 15.0	18.5 ~ 21.0	3.0 ~ 4.0	-
<i>RW317L</i>	0.04	1.0	0.5 ~ 2.5	0.04	0.03	13.0 ~ 15.0	18.5 ~ 21.0	3.0 ~ 4.0	-
<i>RW347</i>	0.08	1.0	0.5 ~ 2.5	0.04	0.03	9.0 ~ 11.0	19.0 ~ 21.5	-	Nb8×C (%) ~ 1.0

Table 2.2.66 Chemical Composition of Deposited Metal for Submerged Arc Welding

Grade	Chemical composition (%)								
	C(max.)	Si(max.)	Mn(max.)	P(max.)	S(max.)	Ni	Cr	Mo	Others
<i>RU308</i>	0.08	1.0	2.5	0.04	0.03	9.0 ~ 11.0	18.0 ~ 21.0	-	-
<i>RU308L</i>	0.04	1.0	2.5	0.04	0.03	9.0 ~ 12.0	18.0 ~ 21.0	-	-
<i>RU309</i>	0.15	1.0	2.5	0.04	0.03	12.0 ~ 14.0	22.0 ~ 25.0	-	-
<i>RU309Mo</i>	0.12	1.0	2.5	0.04	0.03	12.0 ~ 14.0	22.0 ~ 25.0	2.0 ~ 3.0	-
<i>RU310</i>	0.20	1.0	2.5	0.04	0.03	20.0 ~ 22.0	25.0 ~ 28.0	-	-
<i>RU316</i>	0.08	1.0	2.5	0.04	0.03	11.0 ~ 14.0	17.0 ~ 20.0	2.0 ~ 2.75	-
<i>RU316L</i>	0.04	1.0	2.5	0.04	0.03	11.0 ~ 16.0	17.0 ~ 20.0	2.0 ~ 2.75	-
<i>RU317</i>	0.08	1.0	2.5	0.04	0.03	12.0 ~ 14.0	18.0 ~ 21.0	3.0 ~ 4.0	-
<i>RU317L</i>	0.04	1.0	2.5	0.04	0.03	12.0 ~ 16.0	18.0 ~ 21.0	3.0 ~ 4.0	-
<i>RU347</i>	0.08	1.0	2.5	0.04	0.03	9.0 ~ 11.0	18.0 ~ 21.0	-	Nb8×C (%) ~ 1.0

Table 2.2.67 Tensile Test Requirements for Deposited Metal

Electrode for manual arc welding	Consumables for TIG and MIG welding	Flux cored wire for semi-automatic welding	Consumables for submerged arc welding	Tensile strength (N/mm <sup>2</sup> )	Yield strength (N/mm <sup>2</sup> )	Elongation (%)
<i>RD308</i>	<i>RY308</i>	<i>RW308</i>	<i>RU308</i>	550 min.	225 min.	35 min.
<i>RD308L</i>	<i>RY308L</i>	<i>RW308L</i>	<i>RU308L</i>	510 min.	205 min.	35 min.
<i>RD309</i>	<i>RY309</i>	<i>RW309</i>	<i>RU309</i>	550 min.	225 min.	30 min.
<i>RD309L</i>	<i>RY309L</i>	<i>RW309L</i>	-	510 min.	205 min.	30 min.
<i>RD309Mo</i>	<i>RY309Mo</i>	<i>RW309Mo</i>	<i>RU309Mo</i>	550 min.	225 min.	30 min.
<i>RD309MoL</i>	-	<i>RW309MoL</i>	-	510 min.	205 min.	30 min. <sup>(1)</sup>
<i>RD310</i>	<i>RY310</i>	<i>RW310</i>	<i>RU310</i>	550 min.	225 min.	30 min.
-	<i>RY310S</i>	-	-	550 min.	225 min.	30 min.
<i>RD310Mo</i>	-	-	-	550 min.	225 min.	30 min.
<i>RD316</i>	<i>RY316</i>	<i>RW316</i>	<i>RU316</i>	550 min.	225 min.	30 min.
<i>RD316L</i>	<i>RY316L</i>	<i>RW316L</i>	<i>RU316L</i>	510 min.	205 min.	35 min.
<i>RD317</i>	<i>RY317</i>	<i>RW317</i>	<i>RU317</i>	550 min.	225 min.	30 min.
<i>RD317L</i>	<i>RY317L</i>	<i>RW317L</i>	<i>RU317L</i>	510 min.	205 min.	30 min.
-	<i>RY321</i>	-	-	550 min.	225 min.	30 min.
<i>RD347</i>	<i>RY347</i>	<i>RW347</i>	<i>RU347</i>	550 min.	225 min.	30 min.

NOTE:  
(1) Elongation of *RW309MoL* is to be not less than 20 (%).

## 5. Butt weld test

### (1) *Welding of butt weld test assemblies*

- (a) Test assemblies as shown in **Figs 2.2.38** and **2.2.39** are to be welded in each welding position (flat, horizontal, vertical upward, vertical downward and overhead) which is recommended by the manufacturer.
- (b) After each run, the test assembly is to be left in still air until it has cooled to less than 15 0°C but not below 15°C, the temperature being taken at the centre of the weld on the surface of seam.

### (2) *Butt weld tensile test*

- (a) One tensile test specimens to be R2A shown in **Table 2.2.1** is to be taken from each test assembly.
- (b) The tensile strength of each test specimen is to comply with the requirements given in **Table 2.2.68**.
- (c) Submerged arc welding materials used only in the two-run technique are to be selected as one R14A tensile test specimen of **Table 2.2.1**, such that the longitudinal centre line of the test specimen coincides with the weld centre line of the test assemblies and centre of thickness.
- (d) The longitudinal tensile test specimens specified in the preceding (3) may be subjected to the heat treatment not exceeding 250°C for a period not exceeding 16 hours for hydrogen removal prior to testing.
- (e) The tensile strength, yield point and elongation of the test specimens specified in the preceding (c) and (d) are to comply with the requirements given in **Table 2.2.67**.

### (3) *Butt weld bend test*

- (a) The face and root bend test specimens are to be RB4 specimen shown in **Table 2.2.2**, and test specimens are to be taken from each test assembly.
- (b) The test specimens are to be capable of withstanding, without crack exceeding 3 mm long on the outer surface of the specimen or other defects, being bent through an angle of 120 degrees over a former having a radius of 1.5 times the thickness of test specimen.

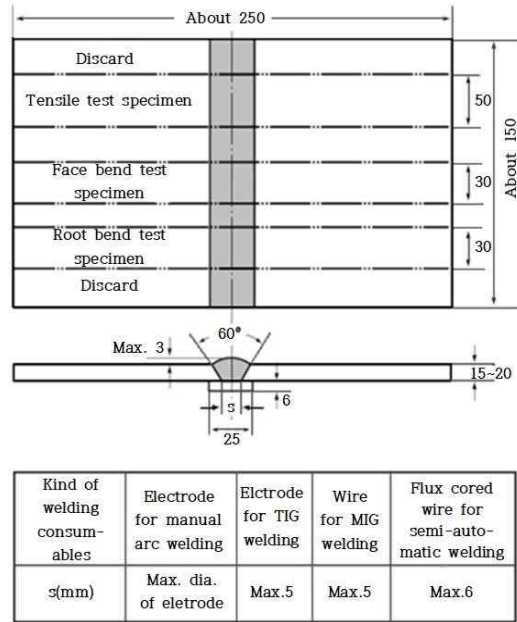


Fig 2.2.38 Butt Weld Test Assembly for Stainless Steel(Except for Submerged arc welding, Unit : mm)

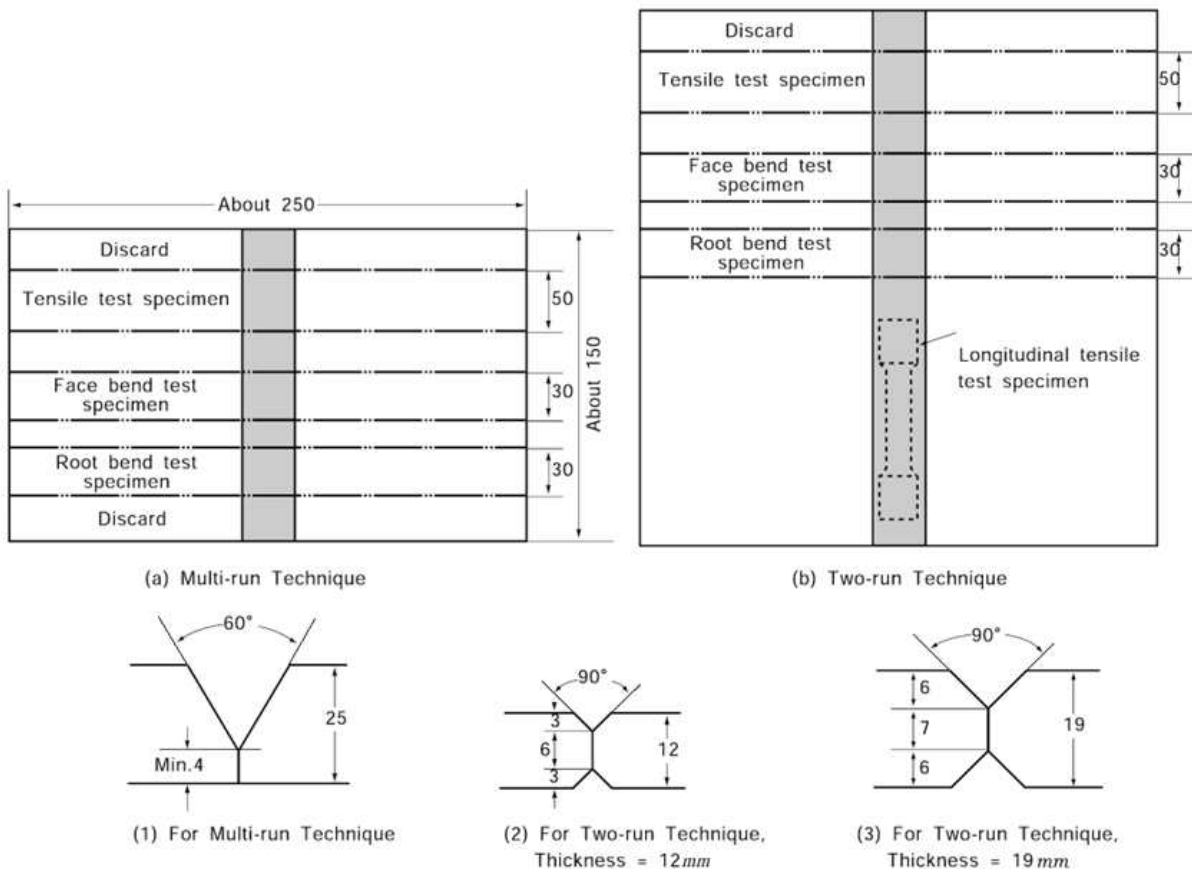


Fig 2.2.39 Butt Weld Test Assembly for Stainless Steel(Submerged arc welding, Unit : mm)

**Table 2.2.68 Tensile Test Requirements for Butt Weld**

Electrode for manual arc welding	Consumables for TIG and MIG welding	Flux cored wire for semi-automatic welding	Consumables for submerged arc welding	Tensile strength (N/mm <sup>2</sup> )
<i>RD308</i>	<i>RY308</i>	<i>RW308</i>	<i>RU308</i>	520 min.
<i>RD308L</i>	<i>RY308L</i>	<i>RW308L</i>	<i>RU308L</i>	480 min.
<i>RD309</i>	<i>RY309</i>	<i>RW309</i>	<i>RU309</i>	520 min.
<i>RD309L</i>	<i>RY309L</i>	<i>RW309L</i>	-	520 min.
<i>RD309Mo</i>	<i>RY309Mo</i>	<i>RW309Mo</i>	<i>RU309Mo</i>	520 min.
<i>RD309MoL</i>	-	<i>RW309MoL</i>	-	520 min.
<i>RD310</i>	<i>RY310</i>	<i>RW310</i>	<i>RU310</i>	520 min.
-	<i>RY310S</i>	-	-	520 min.
<i>RD310Mo</i>	-	-	-	520 min.
<i>RD316</i>	<i>RY316</i>	<i>RW316</i>	<i>RU316</i>	520 min.
<i>RD316L</i>	<i>RY316L</i>	<i>RW316L</i>	<i>RU316L</i>	480 min.
<i>RD317</i>	<i>RY317</i>	<i>RW317</i>	<i>RU317</i>	520 min. <sup>(1)</sup>
<i>RD317L</i>	<i>RY317L</i>	<i>RW317L</i>	<i>RU317L</i>	520 min. <sup>(1)</sup>
-	<i>RY321</i>	-	-	520 min.
<i>RD347</i>	<i>RY347</i>	<i>RW347</i>	<i>RU347</i>	520 min.

NOTE:  
(1) Where the test assembly is made of *RSTS317L*, the tensile strength is not to be less than 480 N/mm<sup>2</sup>.

### 6. Annual inspections

- (1) In the annual inspections, tests specified in the following (2) are to be conducted for each brand of approved consumables, and they are to be passed satisfactorily.
- (2) The kinds of test, etc. in the annual inspections are to be as given in **Table 2.2.69**.
- (3) The welding procedures and requirements of test assemblies for tests in the preceding (2) are to be as specified in **Pars 4** through **5**.

**Table 2.2.69 Kinds of Test at Annual Inspection**

Kind of welding consumables	Kind of test	Welding procedure for test assembly					Kind and number of test specimens taken from test assembly	
		Welding position	Dia. of electrode or wire (mm)	Number	Dimension	Thickness (mm)		
Electrode for manual arc welding	Deposited metal test	Flat	3.2 ~ 4.0	1	<b>Fig 2.2.37</b>	12 ~ 19	Tensile test specimen: 1	
Consumables for TIG welding			2.4 ~ 3.2					
Consumables for MIG welding			1.2 ~ 1.6					
Flux cored wire for semi-automatic welding			1.2 ~ 3.2					
Consumables for submerged arc welding <sup>(1)</sup>	Multi-run technique	Deposited metal test	Flat	1.2 ~ 4.0	1	<b>Fig 2.2.37</b>	19 ~ 25	Tensile test specimen: 1
	Two-run technique	Butt weld test	Flat	2.4 ~ 4.0	1	<b>Fig 2.2.39(b)</b>	12 ~ 19	Tensile test specimen: 1 Longitudinal tensile test specimen: 1 Face bend specimen: 1 Root bend specimen: 1

NOTE:  
(1) Tests on both multi-run and two run technique are to be conducted for multi-run and two run welding respectively and the number, dimensions and thickness of test assemblies, along with the grades and number of test specimens selected from each test assembly are to be according to each of the welding processes. However, longitudinal tensile test of two run technique are not required.

## 608. Welding consumables for aluminium alloys

### 1. Application

- (1) Welding consumables used for aluminium alloys mentioned in the following (a) and (b)(hereinafter referred to as "welding consumables") are to be subjected to the approval tests and annual inspections in accordance with these requirements.
  - (a) Rod-gas combinations for tungsten inert gas arc welding (TIG welding) or plasma arc welding
  - (b) Wire electrode and wire-gas combinations for metal arc inert gas welding (MIG welding), tungsten inert gas arc welding(TIG welding) or plasma arc welding
- (2) Where no special requirements are given herein, e.g. for the approval procedure or for the welding of test assemblies and testing, those as specified in **601.** through **605.** apply in analogous manner.

### 2. Grades and marks of welding consumables

- (1) Grades and marks of welding consumables are classified as given in **Table 2.2.70.**

**Table 2.2.70 Grades and Marks**

Kind of welding consumables	Grade and Mark
Electrode	<i>RA, RB, RC, RD</i>
Wire	<i>WA, WB, WC, WD</i>

- (2) Approval of a wire or a rod will be granted in conjunction with a specific shielding gas according to **Table 2.2.67** with suffixed mark "G"(e.g. *RBG(l-3)*). or defined in terms of composition and purity of "special" gas to be designated with group sign "S"(eg. *RBS(CO<sub>2</sub>, 100%)*). The composition of the shielding gas is to be reported. The approval of a wire or rod with any particular gas can be applied or transferred to any combination of the same wire or rod and any gas in the same numbered group as defined in **Table 2.2.71**, subject to the agreement of the Society.

**Table 2.2.71 Kind of Gas**

Group	Kinds	Gas composition(%)	
		He	Ar
I	I-1	-	100
	I-2	100	-
	I-3	> 0 - 33	Rest
	I-4	> 33 - 66	Rest
	I-5	> 66 - 95	Rest
S		Others	

### 3. General provisions of tests

- (1) Kinds of test, number, thickness and dimensions of test assemblies, kind and number of test specimens taken from each test assembly for welding consumables are to be as given in **Table 2.2.72.**
- (2) The aluminium alloys used in preparation for test assembly corresponding to welding consumables are to be as given in **Table 2.2.73.**
- (3) For the approval of welding consumables, the tests specified in (1) are to be successfully conducted for each brand of welding consumables.
- (4) For welding consumables using a shielding gas, the tests specified in (1) are to be conducted for each kind of gas designated among **Table 2.2.71** by the manufacturer. However, where the manufacturer designates several kinds of gas which are classified into the group I in **Table 2.2.71** and the tests specified in (1) are to be conducted for any one kind of gas, the tests for the other kind of gas may be dispensed with subject to the approval of the Society.

Table 2.2.72 Kinds of Test for Welding Consumables

Kinds of test	Test assembly				Kinds and number of test specimens taken from test assembly
	Welding position	Number	Dimension	Thickness (mm)	
Deposited metal test (Chemical composition test)	Flat	1	Fig 2.2.40	-	-
Butt weld test	Flat	1	Fig 2.2.41	10 ~ 12	Tensile test specimen : 2 Face bend test specimen : 2 Root bend test specimen : 2 Macro structure test specimen : 1
	Horizontal	1 <sup>(1)</sup>			
	Vertical upward	1			
	Overhead	1			
	Flat	1	Fig 2.2.42	20 ~ 25	Tensile test specimen : 2 Face bend test specimen : 2 Root bend test specimen : 2 Macro structure test specimen : 1

Note  
(1) Welding consumables satisfying the requirements for flat and vertical upward positions may be dispensed with the tests for horizontal position subject to the approval of the Society.

Table 2.2.73 Grade of Aluminium Alloys used for Test Assembly

Grade of welding consumables	Grade of aluminium alloys used for test assembly	
RA, WA	5000 series	5754
RB, WB		5086
RC, WC		5083, 5383, 5456, 5059
RD, WD	6000 series	6005A, 6061, 6082

Note:  
Approval on higher strength Al/Mg base materials(5000 series) covers also the lower strength Al/Mg grades and their combination with Al/Si grades

- (5) When the manufacturer designated the gas classified into the group "5" in the tests specified in (4), the composition of the shielding gas is to be reported to the Society.
- (6) After welding, the test assemblies are not to be subjected to any heat treatment or peening.
- (7) It is recommended that the welded assemblies be subjected to a radiographic examination to ascertain that there are any defects in the weld prior to the preparation of test specimens.

4. Deposited metal test

(1) Welding of deposited metal test assembly

- (a) The test assemblies as shown in Fig 2.2.40 are to be welded in flat position in accordance with the welding process designated by the manufacturer.

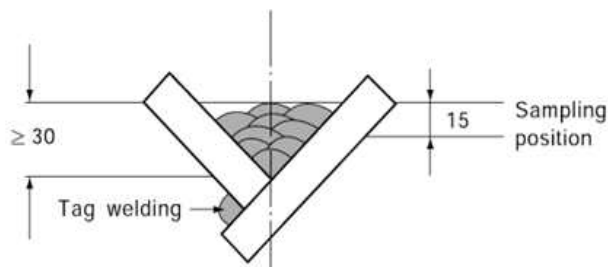


Fig 2.2.40 Deposited Weld Metal Test Assembly (Unit : mm)

- (b) The size of test assembly corresponding to the welding consumables and welding process is to be taken a sufficient amount of pure weld metal for chemical analysis.
- (2) *Chemical composition* The chemical composition of the welding consumables is to be determined by the analysis of the deposited weld metal specified in **Fig 2.2.40** and the results of the analysis are to comply with the limit value specified by the manufacturer.

**5. Butt weld test**

- (1) *Welding of butt weld test assemblies*
  - (a) The test assemblies as shown in **Fig 2.2.41** are to be welded in each welding position designated by the manufacturer (downhand, horizontal, vertical-upward and overhead). The test assembly as shown by **Fig 2.2.42** is to be welded in the downhand position.
  - (b) On completion of each run, the test assemblies are to be allowed to cool naturally in air until the temperature measured at the surface of the centre of the welding joint is ambient temperature. However, the test assemblies for *RD* and *WD* are to be allowed to naturally ageing for a minimum period of 72 hours from the completion of welding before testing.
- (2) *Butt weld tensile test*
  - (a) The tensile test specimens are to be *R2A* specimen shown in **Table 2.2.1** and two test specimens are to be taken from each test assembly.
  - (b) The tensile strength is to comply with the requirements as given in **Table 2.2.74**.

**Table 2.2.74 Requirements for the transverse tensile and bend tests**

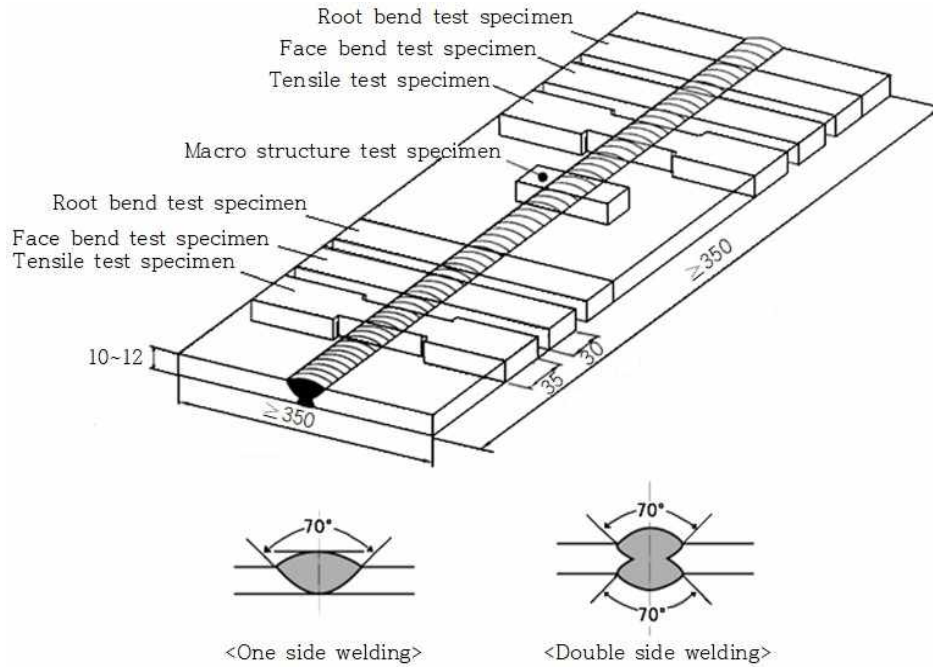
Grade of welding consumables	Base material used for the test	Tensile strength (N/mm <sup>2</sup> )	Bend test	
			Former diameter (mm)	Bending angle
<i>RA/WA</i>	5754	190 min.	3 <i>t</i> <sup>(1)</sup>	180°
<i>RB/WB</i>	5086	240 min.	6 <i>t</i> <sup>(1)</sup>	
<i>RC/WC</i>	5083	275 min.		
	5383, 5456	290 min.		
	5059	330 min.		
<i>RD/WD</i>	6061, 6005A, 6082	170 min.		
Note (1) <i>t</i> : Thickness of the test specimen				

- (3) *Butt Weld Bend Test*
  - (a) The face bend and root bend test specimens are to be *RB4* specimen shown in **Table 2.2.2** and two test specimens are to be taken from each assembly.
  - (b) The test specimens are to sustain the face and root bend tests over 180° using a former having a diameter in accordance with **Table 2.2.74**, without cracks exceeding 3 mm in length and other any defects on the outer surface.
- (4) *Butt weld macro structure test*
  - (a) One macro structure test specimen as shown in **Fig 2.2.41** and **Fig 2.2.42** is to be taken from the butt weld test assembly.
  - (b) The macro structure test specimen is to be examined that there are not any imperfections such as lack of fusion, poor penetration or cracks.

**6. Annual inspections**

- (1) In the annual inspections, every approved welding consumables are to be subjected to the tests provided in (2) and are to be successfully examined.
- (2) Kinds of tests in the annual inspections are to be as given in **Table 2.2.75**.
- (3) The welding procedure and requirements for test assemblies specified in (2) are to be in accordance with the requirements in **4.** to **5.**

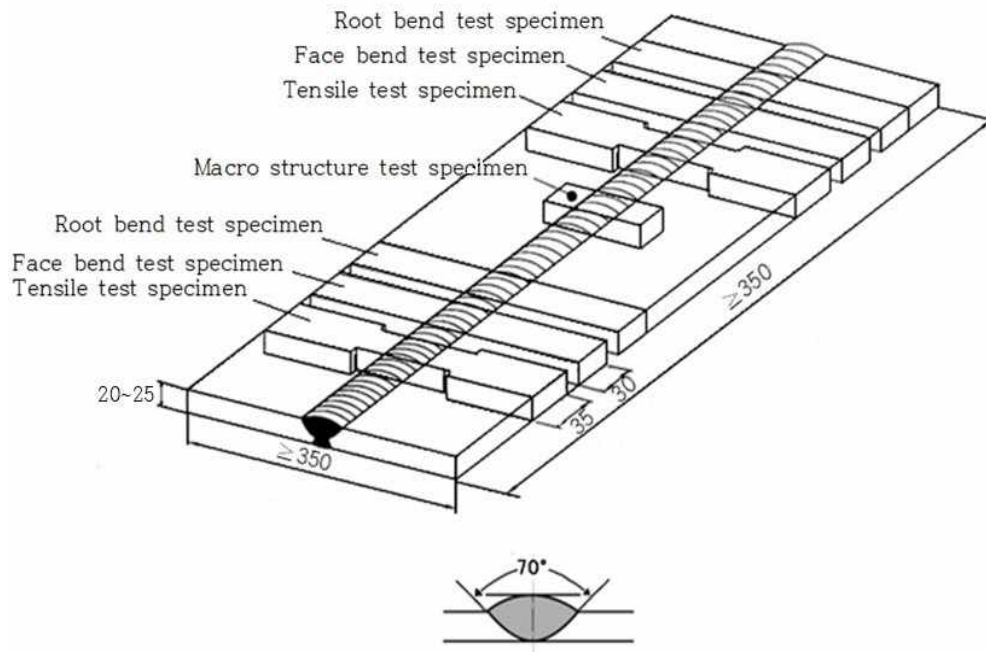




(Note)

- (1) Back sealing runs are allowed in single V weld assembly.
- (2) In case of double V assembly both sides are to be welded in the same welding position.

Fig 2.2.41 Butt Weld Test Assembly for Aluminium Alloys (A thickness of 10 to 12, unit : mm)



(Note)

- (1) Back sealing runs are allowed

Fig 2.2.42 Butt Weld Test Assembly for Aluminium Alloys (A thickness of 20 to 25, unit : mm)

Table 2.2.75 Kinds of Tests in Annual Inspections

Kinds of test	Test assembly				Kind and number of test specimens taken from test assembly
	Welding position	Number	Dimensions	Thickness (mm)	
Deposited weld metal test (Chemical composition Analysis)	Flat	1	Fig 2.2.40	-	-
Butt weld test	Flat	1	Fig 2.2.41	10 - 12	Tensile test specimen : 2 Face bend test specimen : 2 Root bend test specimen : 2 Macro structure test specimen : 1

## 609. Welding consumables for weldable high strength steels

### 1. Application

Welding consumables for weldable high strength steels, which are given in following (1) through (3) (hereinafter referred to as "welding consumables" in 609.) the approval test and annual inspections are to be in accordance with the requirements specified in 609.

- (1) Electrodes for manual arc welding (specified in 602. 1 (1) and (2))
- (2) Automatic welding consumables (specified in 603. 1 (1) and (2). However, in this case, used only for multi-run technique in principle.)
- (3) Semi-automatic welding consumables

### 2. Grade and marks of welding consumables

- (1) Grades and marks of welding consumables are classified as given in Table 2.2.77.
- (2) Where the welding consumables have passed the test specified in 3 (1) below, the suffixes are to be added to the grade marks with the same methods as specified in 603. 2 (2) and (3) or 604. 2 (2) and (3) according to the grade of welding consumables.
- (3) For low hydrogen electrodes which have passed the hydrogen test specified in 6. the suffixes given in Table 2.2.80 are to be added to the grade marks (eg. 3Y46S H5).

### 3. General provisions for tests

- (1) Kinds of test, number, thickness, and dimensions of test assemblies, diameters of electrodes or wires used for welding and welding positions, together with kinds and number of test specimens taken from each test assembly for welding consumables are to be in accordance with the requirements specified in 602. 3., 603. 3. or 604. 3. However, note (4) of Table 2.2.26 and note (5) of Table 2.2.44 are not to be required. Provisions for automatic welding consumables are to be the requirements specified in multi run technique.
- (2) The grades of steels used for tests are to be those given in Table 2.2.76 corresponding to the grades of welding consumables, or those which are considered equivalent by the Society.

**Table 2.2.76 Grade of Steels for Test Assembly (2019)**

Grade of welding consumables	Grade of steel for assembly
2 Y42, 2 Y46, 2 Y50, 2 Y55, 2 Y62, 2 Y69, 2 Y89, 2 Y96	AH 43~AH 97
3 Y42, 3 Y46, 3 Y50, 3 Y55, 3 Y62, 3 Y69, 3 Y89, 3 Y96	AH 43~AH 97, DH 43~DH 97
4 Y42, 4 Y46, 4 Y50, 4 Y55, 4 Y62, 4 Y69, 4 Y89, 4 Y96	AH43~AH97, DH 43~DH 97, EH 43~EH 97
5 Y42, 5 Y46, 5 Y50, 5 Y55, 5 Y62, 5 Y69	AH 43~AH 70, DH 43~DH 70, EH 43~EH 70, FH 43~FH 70
<p>NOTES:</p> <p>Notwithstanding the requirements in this table, normal and higher strength steels may be used for deposited metal test assembly. In this case, appropriate buttering is to be carried out.</p>	

- (3) For the approval of welding consumables, the tests specified in **602.**, **603.** or **604.** are to be conducted for each brand of welding consumables. For the tests specified in **603.**, wire-flux combination for single or two-run technique are subject to special consideration of the Society. (2019)
- (4) After welding, the test assemblies are not to be subjected to any heat treatment or peening.
- (5) It is recommended that the welded assemblies be subjected to a radiographic examination to ascertain that there are any defects in the weld prior to the preparation of test specimens.

#### 4. Deposited metal test

- (1) *Welding of deposited metal test assembly*  
Welding sequence of test assemblies are to be in accordance with the requirements specified in **602. 4 (1)**, **603. 4 (1)** or **604. 4 (1)** appropriate to the grade of the welding consumables.
- (2) *Chemical composition*
  - (a) The chemical composition of the deposited weld metal shall be determined by the manufacturer and reported the results of the analysis to the Society. The report is also to include the main alloy elements.
  - (b) The results of the analysis shall not exceed the limit values specified in the standards or by the manufacturer, the narrower tolerances being applicable in each case.
- (3) *Deposited metal tensile test*
  - (a) Kinds, numbers and selection methods of the deposited metal tensile test specimens being taken from each test assembly are to comply with the requirements specified in **602. 4 (3)**, **603. 4 (3)** or **604. 4 (3)** according to the grade of the welding consumables.
  - (b) The tensile strength, yield strength and elongation of each test specimen are to comply with the requirements specified in **Table 2.2.77** according to the grade of the welding consumables.
  - (c) The provisions specified in the preceding **602. 4 (3) (b)** may be applied to the tensile test specimens.
- (4) *Deposited metal impact test*
  - (a) Kinds, numbers and selection methods of the deposited metal impact test specimens being taken from each test assembly are to comply with the requirements specified in **602. 4 (4)**, **603. 4 (4)** or **604. 4 (4)** according to the grade of the welding consumables.
  - (b) The test temperature and minimum mean absorbed energy are to comply with the requirements specified given in **Table 2.2.77** according to the grade of the welding consumables.
  - (c) The requirements specified in the preceding **602. 4 (4)**, (b) and (d) are to be applied to this test.

Table 2.2.77 Test Requirements for Deposited Metal (2019)

Grade of welding consumables	Tensile test			Impact test	
	Tensile strength (N/mm <sup>2</sup> ) <sup>(1)</sup>	Yield strength (N/mm <sup>2</sup> )	Elongation (%)	Test temp (°C)	Minimum mean absorbed energy(J)
2 Y42	520 ~ 680	420 min.	21 min.	0	47 min.
3 Y42				-20	
4 Y42				-40	
5 Y42				-60	
2 Y46	540 ~ 720	460 min.	20 min.	0	
3 Y46				-20	
4 Y46				-40	
5 Y46				-60	
2 Y50	590 ~ 770	500 min.	19 min.	0	50 min.
3 Y50				-20	
4 Y50				-40	
5 Y50				-60	
2 Y55	640 ~ 820	550 min.	18 min.	0	55 min.
3 Y55				-20	
4 Y55				-40	
5 Y55				-60	
2 Y62	700 ~ 890	620 min.	18 min.	0	62 min.
3 Y62				-20	
4 Y62				-40	
5 Y62				-60	
2 Y69	770 ~ 940	690 min.	17 min.	0	69 min.
3 Y69				-20	
4 Y69				-40	
5 Y69				-60	
2 Y89	940 ~ 1100	890 min.	14 min.	0	69 min.
3 Y89				-20	
4 Y89				-40	
2 Y96	980 ~ 1150	960 min.	13 min.	0	69 min.
3 Y96				-20	
4 Y96				-40	

Note  
Tensile strength specified in the table may be alerted where deemed appropriate by the Society.

### 5. Butt weld test

(1) *Welding of butt weld test assembly*

Welding sequence of test assemblies are to be in accordance with the requirements specified in **602. 5 (1)**, **603. 5 (1)** or **604. 5 (1)** appropriate to the grade of the welding consumables.

(2) *Butt weld tensile test*

(a) Kinds and numbers of the butt weld tensile test specimens being taken from each test assembly are to comply with the requirements specified in **602. 5 (2)**, **603. 5 (2)** or **604. 5 (2)** according to the grade of the welding consumables.

(b) The tensile strength of each test specimen is to meet the requirements given in **Table 2.2.78** according to the grade of the welding consumables.

**Table 2.2.78 Tensile Test Requirements for butt weld test (2017) (2019)**

Grade of welding consumables	Tensile strength (N/mm <sup>2</sup> )
2 Y42, 3 Y42, 4 Y42, 5 Y42	520 min.
2 Y46, 3 Y46, 4 Y46, 5 Y46	540 min.
2 Y50, 3 Y50, 4 Y50, 5 Y50	590 min.
2 Y55, 3 Y55, 4 Y55, 5 Y55	640 min.
2 Y62, 3 Y62, 4 Y62, 5 Y62	700 min.
2 Y69, 3 Y69, 4 Y69, 5 Y69	770 min.
2 Y89, 3 Y89, 4 Y89	940 min.
2 Y96, 3 Y96, 4 Y96	980 min.

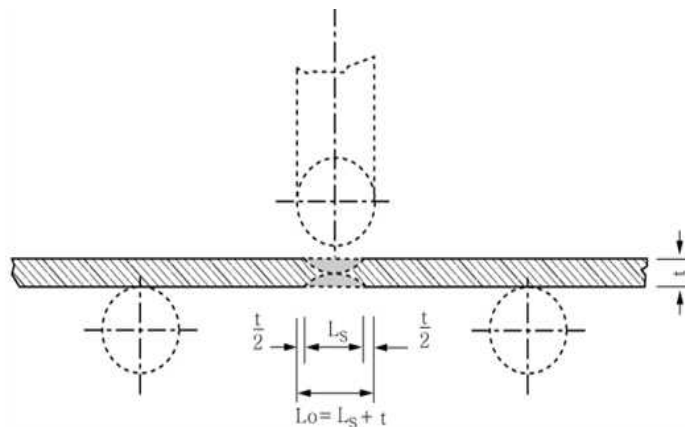
(3) *Butt weld bend test*

- (a) Kinds and numbers of the butt weld face bend and root bend test specimens being taken from each test assembly are to comply with the requirements specified in **602. 5 (3)**, **603. 5 (3)** or **604. 5 (3)** according to the grade of the welding consumables.
- (b) The test specimens are to be subjected to face bend and root bend tests by using former having a radius given in **Table 2.2.79**. Outer surface of the specimens is to be free from any cracks exceeding 3 mm long or other defects when they are bent to the angle of 120 degrees.

**Table 2.2.79 Bend Radius for Butt Weld Bend Test (2019)**

Grade of welding consumable	Radius of plunger
2 Y42~50, 3 Y42~50, 4 Y42~50, 5 Y42~50	2.0 <i>t</i>
2 Y55~69, 3 Y55~69, 4 Y55~69, 5 Y55~69	2.5 <i>t</i>
2 Y89, 3 Y89, 4 Y89	3 <i>t</i>
2 Y96, 3 Y96, 4 Y96	3.5 <i>t</i>

- (c) Where the bending angle 120° is not achieved, the specimen may be considered as fulfilling the requirements, if the bending elongation on a gauge length *L<sub>0</sub>* shown in **Fig 2.2.43** fulfills the minimum elongation requirements stated in **Table 2.2.79** of the Rules.



**Fig 2.2.43 gauge length *L<sub>0</sub>***

(4) *Butt weld impact test*

- (a) Kinds, numbers and selection method of the butt weld impact test specimens being taken from each test assembly are to comply with the requirements specified in **602. 5 (4)**, **603. 5 (4)** or **604. 5 (4)** according to the grade of the welding consumables.
- (b) Testing temperature and minimum mean absorbed energy are to comply with the requirements specified in **Table 2.2.77** according to the grade of the welding consumables.
- (c) The requirements specified in the preceding **602. 5 (4)**, (b) and (d) are to be applied to these tests.

**6. Hydrogen test**

- (1) Hydrogen Test is to be carried out for welding consumables except gas shielded arc solid wire by the glycerine method, mercury method, thermal conductivity detector method or other methods deemed appropriate by the Society. (2017)
- (2) The average volume of hydrogen is to comply with the requirements specified in **Table 2.2.80** according to the test procedures specified in preceding (1) or the type of suffixes to be added to the grade marks.

**Table 2.2.80 Requirements for hydrogen Contents (2017) (2019)**

Grade of welding consumable	Suffixes	Requirements for Hydrogen Contents (cm <sup>3</sup> /g)		
		Glycerine method	Mercury method	Thermal conductivity detector method
2 Y42~50, 3 Y42~50, 4 Y42~50, 5 Y42~50	H10	0.05 max.	0.10 max.	0.10 max.
2 Y55~96, 3 Y55~96, 4 Y55~96, 5 Y55~96	H5	–	0.05 max.	0.05 max.

**7. Fillet weld test assemblies**

- (1) *Welding of fillet weld test assemblies*  
The test assemblies are to be in accordance with the requirements in **602. 7 (1)**.
- (2) *Fillet weld macro-structure test*  
The macro-structure test is to be correspondingly in accordance with the requirements in **602. 7 (2)**.
- (3) *Fillet weld hardness test*  
The hardness test is to be correspondingly in accordance with the requirements in **602. 7 (3)**.
- (4) *Fillet weld fracture test*  
The fracture test is to be correspondingly in accordance with the requirements in **602. 7 (4)**.

**8. Annual inspections**

Annual inspections are to comply with the requirements specified in **602. 8**, **603. 8** or **604. 8** according to the grade of the welding consumables. However, in general, annual inspections for automatic welding consumables are to comply with the requirements specified for multi run technique. For grades Y69 to Y96 annual hydrogen test is required. (2019)

**9. Change in grades**

The changes in grades relating to the strength or toughness or hydrogen of approved welding consumables are to comply with the requirements specified in **602. 9**, **603. 9** or **604. 9** according to the grade of the welding consumables. (2017) ↓



2024

Guidance Relating to  
the Rules for the Classification of Steel Ships

---

Part 2

Materials and Welding

#### APPLICATION OF THE GUIDANCE RELATING TO THE RULES

This "Guidance Relating to the Rules for the Classification of Steel Ships" (hereafter called as the Guidance Relating to the Rules) is prepared with the intent of giving details as to the treatment of the various provisions for items required the unified interpretations and items not specified in the Rules, and the requirements specified in the Guidance Relating to the Rules are to be applied, in principle, in addition to the various provisions in the Rules.

As to any technical modifications which can be regarded as equivalent to any requirements in the Guidance Relating to the Rules, their flexible application will be properly considered.



## **Amendments to the Guidance Relating to the Rules for the Classification of Steel Ships**

1. Unless expressly specified otherwise, the requirements in the Guidance apply to ships/offshore contracted for construction on or after 1 July 2024 and when the application for certification of materials and welding is dated on or after 1 July 2024.
2. The amendments to the Guidance for 2023 edition and their effective date are as follows;

Effective Date 1 July 2024 (based on the application date for certification of materials and welding)

### **CHAPTER 1 MATERIALS**

#### **Section 2 Test Specimens and Testing Procedures**

- 203. 1 (1) (B) and (C) have been amended.
- 203. 1 (2) and (3) have been amended.
- 203. 2 (1) (C) has been amended.
- 203. 2 (2) has been amended.
- Table 2.1.3 of 203. 2 (2) has been amended.
- 203. 2 (3) (D) has been amended.
- 203. 2 (4) (A) (a) has been amended.
- 203. 2 (4) (B) (a) has been amended.
- 203. 2 (4) (D) (d) has been amended.
- 203. 2 (4) (E) (a) has been amended.
- 203. 2 (4) (F) has been amended.
- 203. 2 (5) (B) (d) (vi) has been amended.
- 203. 2 (5) (C) (b) has been amended.
- 203. 2 (7) (A) has been amended.

#### **Section 3 Rolled Steels**

- 312. 2 has been newly added.

#### **Section 5 Castings**

- 501. 2 has been deleted.

### **CHAPTER 2 WELDING**

#### **Section 3 Welding Works and Inspection**

- Table 2.2.4 of 306. 1 has been amended.

# CONTENTS

<b>CHAPTER 1 MATERIALS</b> .....	<b>1</b>
Section 1 General .....	1
101. Application .....	1
102. Approval of manufacturing process and manufacturing control .....	1
103. Chemical composition .....	1
104. Testing and inspection .....	1
107. Test certificates .....	2
109. Retest procedure .....	2
Section 2 Test Specimens and Testing Procedures .....	3
201. General .....	3
202. Form and dimension of test specimen .....	3
203. Testing procedure .....	4
Section 3 Rolled Steels .....	15
301. Rolled steels for hull structural .....	15
302. Rolled steel plates for boilers .....	17
303. Rolled steel plates for pressure vessels .....	18
304. Rolled steels for low temperature service .....	18
305. Rolled stainless steels .....	18
306. Round bars for chain .....	19
307. Rolled steel bars for boiler .....	19
308. High Strength Steels for Welded Structures .....	19
309. Stainless clad steel plates .....	19
310. Additional requirements for through thickness properties .....	20
312. Brittle crack arrest steels .....	20
Section 4 Steel Tubes and Pipes .....	27
401. Steel tubes for boilers and heat exchangers .....	27
402. Steel pipes for pressure piping .....	28
403. Stainless steel pipes .....	28
404. Steel pipes for low temperature service .....	29
Section 5 Castings .....	30
501. Steel castings .....	30
502. Steel castings for chains .....	31
505. Stainless steel casting for propeller .....	31
506. Grey iron casting .....	35
507. Spheroidal or nodular graphite iron castings .....	35
Section 6 Steel Forgings .....	36
601. Steel Forgings .....	36
603. Steel forgings for chains .....	38
Section 7 Copper and Copper Alloys .....	39

702. Copper alloy castings .....	39
Section 8 Aluminium Alloys .....	40
801. Aluminium alloys .....	40
802. Aluminium/steel transition joints .....	41
<b>CHAPTER 2 WELDING .....</b>	<b>43</b>
Section 1 General .....	43
102. Matters to be approved .....	43
103. Special weldings .....	43
Section 3 Welding Works and Inspection .....	45
303. Application of welding consumables .....	45
304. Preparation for Welding .....	45
305. Welding sequence and direction of welding .....	45
306. Main welding .....	47
309. Quality of welds .....	48
Section 4 Welding Procedure Qualification Tests .....	49
403. Welding procedure qualification tests(WPQT) .....	49
404. Butt welded joints .....	51
405. Test for fillet welded joints .....	52
406. Retests and Procedure qualification records(PQR) .....	52
407. Validity of qualified welding procedure specification .....	52
Section 5 Welders and Welder Performance Qualification Scheme .....	53
503. Testing procedure .....	53
504. General requirements for qualification validity .....	53
Section 6 Welding Consumables .....	54
601. General .....	54
602. Electrodes for manual arc welding for normal strength steels, higher strength steels and steels for low temperature service .....	54
606. One side welding consumables for normal strength steels, higher strength steels and steels for low temperature service .....	55
607. Welding consumables for stainless steels .....	55
 <b>&lt;ANNEX&gt;</b>	
Annex 2-1 Guidance for seamless forged steel drums .....	58
Annex 2-2 Guidance for non-destructive testing of marine steel castings .....	59
Annex 2-3 Guidance for surface inspection of cast steel crankshafts .....	70
Annex 2-4 Guidance for repairs by welding for cast steel crank throws .....	73
Annex 2-5 Guidance for non-destructive examination of hull and machinery steel forgings .....	76
Annex 2-6 Guidance for liquid penetrant inspection and repair of defects of copper alloy propeller castings .....	89
Annex 2-7 Guidance for non-destructive testing of ship hull steel welds .....	101
Annex 2-8 Reinforced plastic materials .....	118

Annex 2-9	Offshore mooring chain .....	123
Annex 2-10	Hull Structural Steels with Improved Fatigue Properties .....	130
Annex 2-11	High manganese austenitic steels .....	135
Annex 2-12	Guidance for advanced non-destructive testing of materials and welds .....	139

## CHAPTER 1 MATERIALS

### Section 1 General

#### 101. Application [See Rule]

1. Seamless shells of boilers made of steel forgings are to comply with **Annex 2-1**.
2. Reinforced plastic materials used for construction or repair of FRP ships or composite vessel are to comply with **Annex 2-8**. (2017)
3. Hull structural steels with improved fatigue properties are to comply with **Annex 2-10**.
4. The application to **101. 2** of the Rules is to be in accordance with the followings: (2019)
  - (1) For the material equivalent to those specified **Pt 2, Ch 1** of Rules (the material specified **ISO, ASTM**, etc.), except as otherwise specified, chemical composition, mechanical properties and heat treatment may be in accordance with the relevant standards.
  - (2) The requirements for **Pt 2, Ch 1** of Rules are to be applied for approval of manufacturing process, testing and inspection of material in (1) above. This is not absolute the approval and inspection of the Society.
  - (3) "otherwise specified" in (1) above generally means requirements according to the application.
5. The high manganese austenitic steel for cargo tank in ships carrying liquefied natural gases in bulk or for fuel tank in ships using liquefied natural gases as fuels is to comply with **Annex 2-11**. (2020)

#### 102. Approval of manufacturing process and manufacturing control

1. "control imperfection" referred in **102. 2** (2) of the Rules includes the deviation from the programmed rolling schedules or normalizing or quenching and tempering procedures. **[See Rule]**
2. "at the discretion of the Society" referred in **102. 2** (3) of the Rules includes the confirmation for compliance monitoring of a countermeasure to prevent its recurrence in the complete investigation report. **[See Rule]**

#### 103. Chemical composition

1. The application to **103. 1** of the Rules is to be in accordance with the followings: **[See Rule]**
  - (1) The chemical composition analyses from each ladle are to be applied to steel.
  - (2) The chemical composition analyses from each cast are to be applied to non-ferrous metals.
2. "if required by the Surveyor" referred in **103. 2** of the Rules means where a low reliability of the manufacturer's declared analysis is verified by the Society. **[See Rule]**
3. The application to **103. 3** of the Rules is to be in accordance with the followings : **[See Rule]**
  - (1) Selection of samples for the check analyses  
Samples for the check analyses are to be taken from specimens for mechanical tests or from the portion of the body adjacent to the part where mechanical specimens had been taken.
  - (2) Production analysis and its tolerance for steel  
Production analysis and its tolerance for steel is to comply with *KS D0228* (Production Analysis and its Tolerance for Wrought Steel) or the standard internationally recognized subject to the approval by the Society.

#### 104. Testing and inspection [See Rule]

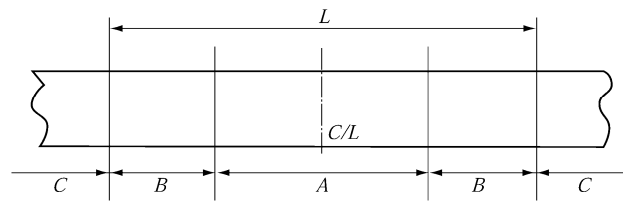
"The approval of quality assurance scheme specially specified by the Society" referred in **104. 4** of the Rules means where the quality assurance scheme of material manufacturer has been already approved according to the requirements of **Ch 5** of "Guidance for Approval of Manufacturing Process and Type approval etc." by the Society.

**107. Test certificates (2019) [See Rule]**

Chemical composition and mechanical test results for materials are to be measured until the next digit of the least significant digit of required significant figures. Then, such measurements are to be rounded off in accordance with *ISO 80000-1 Annex B*, and to be indicated in the same number of significant figures as the specified value. The applicant is to be consulted with the Society when other methods are used.

**109. Retest procedure [See Rule]**

"Any part of fracture is outside the one-fourth of the gauge length from the centre of gauge length" specified in **109. 4** of the Rules means the parts of "B" and "C" as shown in **Fig 2.1.1** of the Guidance.



- $L$  : Gauge length
- $A$  : Inside the one-fourth of the gauge length from the centre of gauge length
- $B$  : Between outside the one-fourth of the gauge length from the centre of gauge length and inside gauge length
- $C$  : Over gauge length

**Fig 2.1.1 Divisions for Fracture Parts of Tensile Specimen**

## Section 2 Test Specimens and Testing Procedures

### 201. General

#### 1. Application

In case where test specimens or test procedures specified in the requirements of *ISO* or *KS* are adopted, the approvals by the Society may be dispensed with, notwithstanding the requirement in **201. 1 (2)** of the Rules. **[See Rule]**

#### 2. Testing machine

In application to **201. 2 (2)** and **(3)** of the Rules, the term "other recognised standard" means the acceptance in accordance with **Pt 1, Ch 1, 105.** of the Rules. **[See Rule]**

#### 3. Selection of test specimens

"Where otherwise specified or agreed with the Surveyor" referred in **201. 3 (2)** of the Rules means only where manufacturing process of the material has been already approved according to the requirements of **Ch 2** of "*Guidance for Approval of Manufacturing Process and Type Approval, etc*" by the Society **[See Rule]**

### 202. Form and dimension of test specimen

#### 1. Tensile test specimen

- (1) The gauge length of the *R14B* tensile test specimens specified in **Fig 2.1.1** of the Rules may be used as given in **Table 2.1.1** of Guidance in accordance with **201. 1 (2)** of the Rules. **[See Rule]**

**Table 2.1.1 Rounding of Gauge Length**

Thickness of test specimen t (mm)	Width of test specimen W (mm)	Gauge length L (mm)
$3 \leq t \leq 4$	25	50
$4 < t \leq 5$		60
$5 < t \leq 7$		70
$7 < t \leq 10$		80
$10 < t \leq 15$		100
$15 < t \leq 20$		120
$20 < t \leq 30$		140
$30 < t \leq 40$		160

- (2) In application to **202. 1 (4)** of the Rules, corrections for elongation are to be in accordance with the followings : **[See Rule]**
- (A) Stainless steel and aluminium alloys are to be considered as Material 1 in **Table 2.1.1** of the Rules. However, corrections for elongation specified in **202. 1 (4)** of the Rules may not be required in the case of copper alloy.
- (B) In case where the corrections by the requirements of **202. 1 (4)** of the Rules are deemed troublesome because of a great number of test specimens, the value of specified elongation may be corrected by using the following formula. In such case, the corrected specified elongation is to be recorded in the certificates of the material test.

$$E = n \cdot F$$

where

- $E$  = Elongation equivalent to where the proportional specimens ( $L=5.65\sqrt{A}$ ) specified in Fig 2.1.1 of the Rules are used.
- $n$  = Elongation where optional test specimens are used.
- $F$  = Coefficient of correction for elongation are shown in Table 2.1.2 of the Guidance according to the gauge length.

Table 2.1.2 Values of  $F$

Gauge length ( $L$ )	Material 1	Material 2
$8D$	1.21	1.29
$8\sqrt{A}$	1.15	1.21
$4D$	0.91	0.88
$4\sqrt{A}$	0.87	0.82

$D$  : Diameter of the test specimen  
 $A$  : Sectional area of the test specimen

## 2. Impact test specimen

- (1) In application to 202. 3 (3) of the Rules, the sub-size specimens permitted according to thickness of the steels are to be as follows; **【See Rule】**

Steel thickness	Width of the sub-size specimen
$6\text{ mm} \leq t < 9\text{ mm}$	5 mm
$9\text{ mm} \leq t < 12\text{ mm}$	7.5 mm

- (2) In application to 202. 3 (5) of the Rules, in case where the capacity of impact tester limits the use of normal impact test specimens, sub-size specimens can be used provided that the test results using sub-size specimens are to comply with the requirements specified for the normal impact test specimens. **【See Rule】**

## 203. Testing procedure (2017) (2021)

### 1. Test method for Brittle crack arrest toughness, $K_{ca}$ **【See Rule】**

- (1) Scope
- (A) In application to 203. of the Rules, this test procedure for brittle crack arrest toughness (i.e.  $K_{ca}$ ) of steel using fracture mechanics parameter is applicable to hull structural steels with the thickness over 50 mm and not greater than 100 mm. (2024)
- (B) **ISO20064: 2019** provides a test method for the determination of brittle crack arrest toughness of steel by using wide plates with a temperature gradient. (2024)
- (C) These requirements specify the test procedures for brittle crack arrest toughness (i.e.  $K_{ca}$ ) of steel using fracture mechanics parameter and determination method of  $K_{ca}$  at a specific temperature which are specified in **ISO 20064:2019**. Additionally, this requirements specify the evaluation method of  $K_{ca}$  of test plate. (2024)
- (2) Test procedures (2024)
- The test procedures including testing equipment, test specimens, test methods, determination of arrest toughness, reporting of test results, etc. are to be in accordance with **ISO 20064: 2019**. As a method for initiating a brittle crack, a secondary loading mechanism can be used in accordance with Annex D of **ISO 20064: 2019**, except that the first sentence in Annex B.2.4 of **ISO 20064: 2019** is revised to "Obtain the value  $\{K_{ca}/[K_0 \cdot \exp(-c/T_{Kca})]\}$  for each data point".
- (3) Determination of  $K_{ca}$  at a specific temperature and the evaluation (2024)
- (A) Method
- The method for conducting multiple tests to obtain  $K_{ca}$  value at a specific temperature is to



be in accordance with Annex B of ISO 20064: 2019.

(B) Evaluation

The straight-line approximation of Arrhenius plot for valid  $K_{ca}$  data by interpolation method are to comply with either the following (a) or (b).

- (a) The evaluation temperature of  $K_{ca}$  (i.e. -10 degree C) is located between the upper and lower limits of the arrest temperature, with the  $K_{ca}$  corresponding to the evaluation temperature not lower than the required  $K_{ca}$  (e.g. 6,000  $N/mm^{3/2}$  or 8,000  $N/mm^{3/2}$ ), as shown in Fig 2.1.2 of the Guidance.

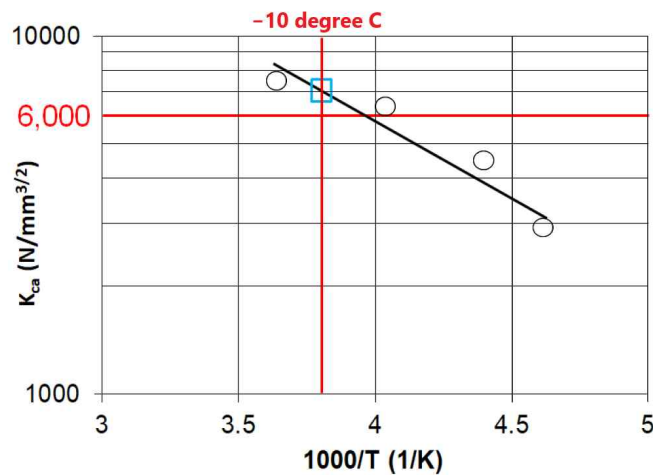


Fig 2.1.2 Example for evaluation of  $K_{ca}$  at -10 degree C

- (b) The temperature corresponding to the required  $K_{ca}$  (e.g. 6,000  $N/mm^{3/2}$  or 8,000  $N/mm^{3/2}$ ) is located between the upper and lower limits of the arrest temperature, with the temperature corresponding to the required  $K_{ca}$  not higher than the evaluation temperature (i.e. -10 degree C), as shown in Fig 2.1.3 of the Guidance.
- (c) If both of (b) and (c) above are not satisfied, conduct additional tests to satisfy this condition.

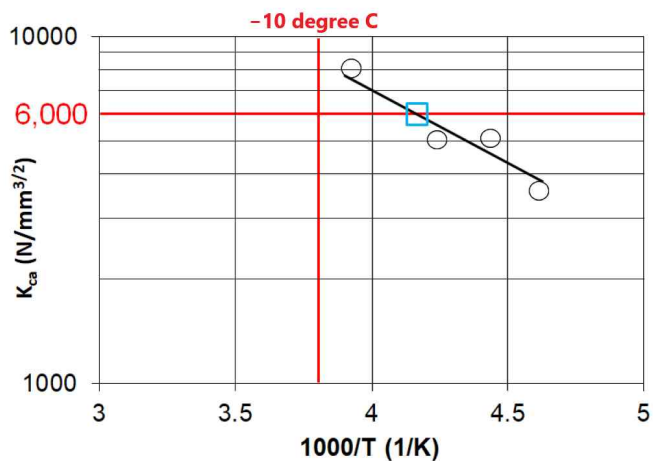


Fig 2.1.3 Example for evaluation of temperature corresponding to the required  $K_{ca}$

2. Outline of requirements for undertaking isothermal Crack Arrest Temperature

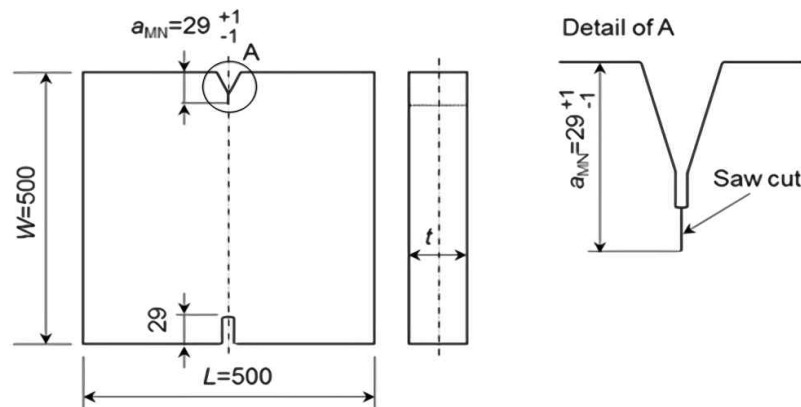
- (1) Application
- (A) These requirements are to be applied according to the scope defined in **Pt 2, Ch 1, 312.** of the Rules.
  - (B) These are requirements for test procedures and test conditions when using the isothermal crack arrest test to determine a valid test result under isothermal conditions and in order to establish the crack arrest temperature(CAT). These requirements are applicable to steels with thickness over 50 mm and not greater than 100 mm.
  - (C) This method uses an isothermal temperature in the test specimen being evaluated. Unless otherwise specified in these requirements, the other test parameters are to be in accordance with **ISO 20064:2019. (2024)**
  - (D) **Table 2.1.35** of **Pt 2, Ch 1, 312.** of the Rules gives the relevant requirements for the brittle crack arrest property described by the crack arrest temperature(CAT).
  - (E) The manufacturer is to submit the test procedure to the Society for review prior to testing.
  - (F) Where required, the method can also be used for determining the lowest temperature at which a steel can arrest a running brittle crack (the determined CAT) as the material property characteristic in accordance with (8) (C).
- (2) Symbols and their significance
- Table 2.1.3** of the Guidance supplements **Table 1** in **ISO 20064:2019** with specific symbols for the isothermal test. *(2024)*

**Table 2.1.3 Nomenclature supplementary to Table 1 in ISO 20064: 2019 (2024)**

Symbol	Unit	Significance
t	mm	Test specimen thickness
L	mm	Test specimen length
W	mm	Test specimen width
$a_{MN}$	mm	Machined notch length on specimen edge
$L_{SG}$	mm	Side groove length on side surface from the specimen edge. $L_{SG}$ is defined as a groove length with constant depth except a curved section in depth at side groove end.
$d_{SG}$	mm	Side groove depth in section with constant depth
$L_{EB-min}$	mm	Minimum length between specimen edge and electron beam re-melting zone front
$L_{EB-s1,-s2}$	mm	Length between specimen edge and electron beam re-melting zone front appeared on both specimen side surfaces
$L_{LTG}$	mm	Local temperature gradient zone length for brittle crack runway
$a_{arrest}$	mm	Arrested crack length
$T_{target}$	°C	Target test temperature
$T_{test}$	°C	Defined test temperature
$T_{arrest}$	°C	Target test temperature at which valid brittle crack arrest behaviour is observed
$\sigma$	$N/mm^2$	Applied test stress at cross section of $W \times t$
SMYS	$N/mm^2$	Specified minimum yield strength of the tested steel grade to be approved
CAT	°C	Crack arrest temperature, the lowest temperature, $T_{arrest}$ , at which running brittle crack is arrested

- (3) Testing equipment
- (A) The test equipment to be used is to be of the hydraulic type of sufficient capacity to provide a tensile load equivalent to  $\frac{2}{3}$  of SMYS of the steel grade to be approved.
  - (B) The temperature control system is to be equipped to maintain the temperature in the specified region of the specimen within  $\pm 2$  °C from  $T_{target}$ .
  - (C) Methods for initiating the brittle crack may be of drop weight type, air gun type or double tension tab plate type.
  - (D) The detailed requirements for testing equipment are specified in **ISO 20064:2019. (2024)**
- (4) Test specimens
- (A) Impact type crack initiation

- (a) Test specimens are to be in accordance with **ISO 20064:2019**, unless otherwise specified in these requirements. (2024)
- (b) Specimen dimensions are shown in **Fig 2.1.4** of the Guidance. The test specimen width,  $W$  shall be 500mm. The test specimen length,  $L$  shall be equal to or greater than 500mm.



**Fig 2.1.4 Test specimen dimensions for an impact type specimen**

- (c) V-shape notch for brittle crack initiation is machined on the specimen edge of the impact side. The whole machined notch length shall be equal to 29 mm with a tolerance range of  $\pm 1$  mm.
- (d) Requirements for side grooves are described in (D).
- (B) Double tension type crack initiation
  - (a) Reference shall be made to Annex D in **ISO 20064:2019** for the shape and sizes in secondary loading tab and secondary loading method for brittle crack initiation. (2024)
  - (b) In a double tension type test, the secondary loading tab plate may be subject to further cooling to enhance an easy brittle crack initiation.
- (C) Embrittled zone setting
  - (a) An embrittled zone shall be applied to ensure the initiation of a running brittle crack. Either Electron Beam Welding (EBW) or Local Temperature Gradient (LTG) may be adopted to facilitate the embrittled zone.
  - (b) In EBW embrittlement, electron beam welding is applied along the expected initial crack propagation path, which is the centre line of the specimen in front of the machined V-notch.
  - (c) The complete penetration through the specimen thickness is required along the embrittled zone. One side EBW penetration is preferable, but dual sides EBW penetration may be also adopted when the EBW power is not enough to achieve the complete penetration by one side EBW.
  - (d) The EBW embrittlement is recommended to be prepared before specimen contour machining.
  - (e) In EBW embrittlement, zone shall be of an appropriate quality.
  - (f) EBW occasionally behaves in an un-stable manner at start and end points. EBW line is recommended to start from the embrittled zone tip side to the specimen edge with an increasing power control or go/return manner at start point to keep the stable EBW.
  - (g) In LTG system, the specified local temperature gradient between machined notch tip and isothermal test region is regulated after isothermal temperature control. LTG temperature control is to be achieved just before brittle crack initiation, nevertheless the steady temperature gradient through the thickness shall be ensured.
- (D) Side grooves
  - (a) Side grooves on side surface can be machined along the embrittled zone to keep brittle crack propagation straight. Side grooves shall be machined in the specified cases as specified in this section.
  - (b) In EBW embrittlement, side grooves are not necessarily mandatory. Use of EBW avoids the shear lips. However, when shear lips are evident on the fractured specimen, e.g.

- shear lips over 1 mm in thickness in either side then side grooves should be machined to suppress the shear lips.
- (c) In LTG embrittlement, side grooves are mandatory. Side grooves with the same shape and size shall be machined on both side surfaces.
  - (d) The length of side groove,  $L_{SG}$  shall be no shorter than the sum of the required embrittled zone length. (2024)
  - (e) When side grooves would be introduced, the side groove depth, the tip radius and the open angle are not regulated, but are adequately selected in order to avoid any shear lips over 1 mm thickness in either side. An example of side groove dimensions are shown in Fig 2.1.5 of the Guidance.
  - (f) Side groove end shall be machined to make a groove depth gradually shallow with a curvature larger than or equal to groove depth,  $d_{SG}$ . Side groove length,  $L_{SG}$  is defined as a groove length with constant depth except a curved section in depth at side groove end.

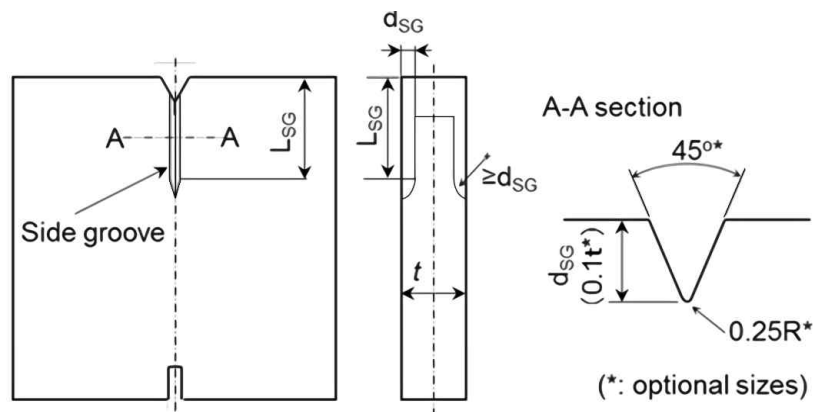


Fig 2.1.5 Side groove configuration and dimensions

- (E) Nominal length of embrittled zone
- (a) The length of embrittled zone shall be at least 150 mm. (2024)

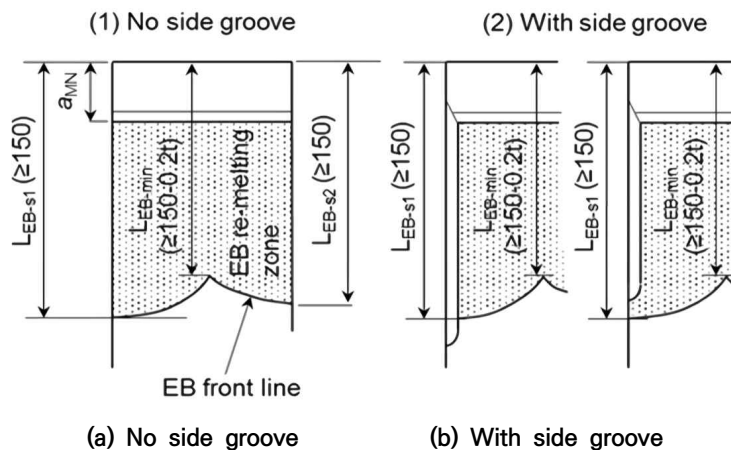
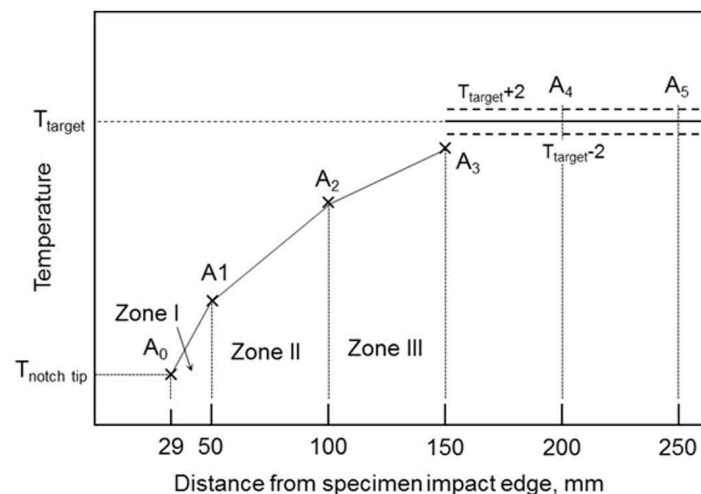


Fig 2.1.6 Side groove configuration and dimension

- (b) EBW zone length is regulated by three measurements on the fracture surface after test as shown in Fig 2.1.6 of the Guidance,  $L_{EB-min}$  between specimen edge and EBW front line, and  $L_{EB-s1}$  and  $L_{EB-s2}$ .
- (c) The minimum length between specimen edge and EBW front line,  $L_{EB-min}$  should be no smaller than 150 mm. However, it can be acceptable even if  $L_{EB-min}$  is no smaller than  $150\text{mm}-0.2t$ , where  $t$  is specimen thickness. When  $L_{EB-min}$  is smaller than 150 mm, a temperature safety margin shall be considered into  $T_{test}$  (See (8) (A) (b)).
- (d) Another two are the lengths between specimen edge and EBW front appeared on both

side surfaces, as denoted with  $L_{EB-s1}$  and  $L_{EB-s2}$ . Both of  $L_{EB-s1}$  and  $L_{EB-s2}$  shall be no smaller than 150 mm.

- (e) In LTG system,  $L_{LTG}$  is set as 150 mm.
- (F) Tab plate / pin chuck details and welding of test specimen to tab plates  
The configuration and size of tab plates and pin chucks shall be referred to **ISO 20064:2019**. The welding distortion in the integrated specimen, which is welded with specimen, tab plates and pin chucks, shall be also within the requirement in **ISO 20064:2019**. (2024)
- (5) Test method
  - (A) Preloading  
Preloading at room temperature can be applied to avoid unexpected brittle crack initiation at test. The applied load value shall be no greater than the test stress. Preloading can be applied at higher temperature than ambient temperature when brittle crack initiation is expected at preloading process. However, the specimen shall not be subjected to temperature higher than 100 °C.
  - (B) Temperature measurement and control
    - (a) Temperature control plan showing the number and position of thermocouples is to be in accordance with this section.
    - (b) Thermocouples are to be attached to both sides of the test specimen at a maximum interval of 50 mm in the whole width and in the longitudinal direction at the test specimen centre position (0.5 W) within the range of ±100 mm from the centreline in the longitudinal direction, refer to **Fig 2.1.7** of the Guidance.



**Fig 2.1.7** Locations of temperature measurement

- (c) For EBW embrittlement
  - (i) The temperatures of the thermocouples across the range of 0.3W~0.7W in both width and longitudinal directions are to be controlled within  $\pm 2\text{ }^{\circ}\text{C}$  of the target test temperature,  $T_{target}$ .
  - (ii) When all measured temperatures across the range of 0.3W~0.7W have reached  $T_{target}$ , steady temperature control shall be kept at least for  $10 + 0.1 \times t[\text{mm}]$  minutes to ensure a uniform temperature distribution into mid-thickness prior to applying test load.
  - (iii) The machined notch tip can be locally cooled to easily initiate brittle crack. Nevertheless, the local cooling shall not disturb the steady temperature control across the range of 0.3W~0.7W.
- (d) For LTG embrittlement
  - (i) In LTG system, in addition to the temperature measurements shown in **Fig 2.1.7** of the Guidance, the additional temperature measurement at the machine notch tip,  $A_0$  and  $B_0$  is required. Thermocouples positions within LTG zone are shown in **Fig 2.1.8** of the Guidance.

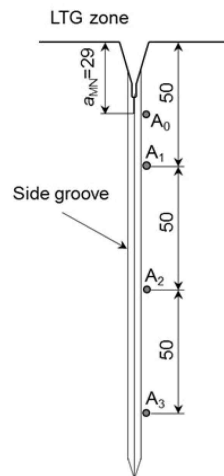


Fig 2.1.8 Detail of LTG zone and additional thermocouple  $A_0$

- (ii) The temperatures of the thermocouples across the range of 0.3W~0.7W in both width and longitudinal directions are to be controlled within  $\pm 2^\circ\text{C}$  of the target test temperature,  $T_{target}$ . However, the temperature measurement at 0.3W (location of  $A_3$  and  $B_3$ ) shall be in accordance with (f) below.
- (iii) Once the all measured temperatures across the range of 0.3W~0.7W have reached  $T_{target}$ , steady temperature control shall be kept at least for  $10 + 0.1 \times t[\text{mm}]$  minutes to ensure a uniform temperature distribution into mid-thickness, then the test load is applied.
- (iv) LTG is controlled by local cooling around the machined notch tip. LTG profile shall be recorded by the temperature measurements from  $A_0$  to  $A_3$  shown in **Fig 2.1.9** of the Guidance.
- (v) LTG zone is established by temperature gradients in three zones, Zone I, Zone II and Zone III. The acceptable range for each temperature gradient is listed **Table 2.1.4**.
- (vi) Temperature measurements at  $A_2$ ,  $B_2$  and  $A_3$ ,  $B_3$  shall be satisfied the following requirements. (2024)

$$\begin{aligned} T \text{ at } A_3, T \text{ at } B_3 &< T_{target} - 2^\circ\text{C} \\ T \text{ at } A_2 &< T \text{ at } A_3 - 5^\circ\text{C} \\ T \text{ at } B_2 &< T \text{ at } B_3 - 5^\circ\text{C} \end{aligned}$$

- (vii) No requirements for  $T$  at  $A_0$  and  $T$  at  $A_1$  temperatures when  $T$  at  $A_3$  and  $T$  at  $A_2$  satisfy the requirements above. Face B is the same.
- (viii) The temperatures from  $A_0$ ,  $B_0$  to  $A_3$ ,  $B_3$  should be decided at test planning stage refer to **Table 2.1.4** which gives the recommended temperature gradients in three zones, Zone I, Zone II and Zone III in LTG zone.

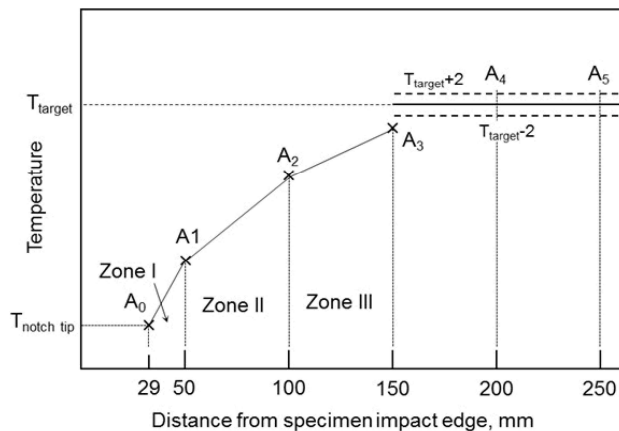


Fig 2.1.9 Schematic temperature gradient profile in LTG zone

Table 2.1.4 Acceptable LTG range

Zone	Location from edge	Acceptable range of temperature gradient
Zone I	29 mm~50 mm	2.00 °C/mm ~ 2.30 °C/mm
Zone II	50 mm~100 mm	0.25 °C/mm ~ 0.60 °C/mm
Zone III <sup>(1)</sup>	100 mm~150 mm	0.10 °C/mm ~ 0.20 °C/mm

NOTES:  
(1) The Zone III arrangement is mandatory

- (ix) The temperature profile in LTG zone mentioned above shall be ensured after holding time at least for  $10 + 0.1 \times t$  [mm] minutes to ensure a uniform temperature distribution into mid-thickness before brittle crack initiation.
- (x) The acceptance of LTG in the test shall be decided from **Table 2.1.4** based on the measured temperatures from  $A_0$  to  $A_3$ .
- (e) For double tension type crack initiation specimen  
Temperature control and holding time at steady state shall be the same as the case of EBW embrittlement specified in (c) or the case of LTG embrittlement specified in Section (d).
- (C) Loading and brittle crack initiation
  - (a) Prior to testing, a target test temperature ( $T_{target}$ ) shall be selected.
  - (b) Test procedures are to be in accordance with **ISO 20064:2019** except that the applied stress is to be  $\frac{2}{3}$  of SMYS of the steel grade tested. (2024)
  - (c) The test load shall be held at the test target load or higher for a minimum of 30 seconds prior to crack initiation.
  - (d) Brittle crack can be initiated by impact or secondary tab plate tension after all of the temperature measurements and the applied force are recorded.
- (6) Measurements after test and test validation judgement
  - (A) Brittle crack initiation and validation
    - (a) If brittle crack spontaneously initiates before the test force is achieved or the specified hold time at the test force is not achieved, the test shall be invalid.
    - (b) If brittle crack spontaneously initiates without impact or secondary tab tension but after the specified time at the test force is achieved, the test is considered as a valid initiation. The following validation judgments of crack path and fracture appearance shall be examined.
  - (B) Crack path examination and validation
    - (a) When brittle crack path in embrittled zone deviates from EBW line or side groove in LTG system due to crack deflection and/or crack branching, the test shall be considered as invalid.
    - (b) All of the crack path from embrittled zone end shall be within the range shown in **Fig**

2.1.10 of the Guidance. If not, the test shall be considered as invalid.

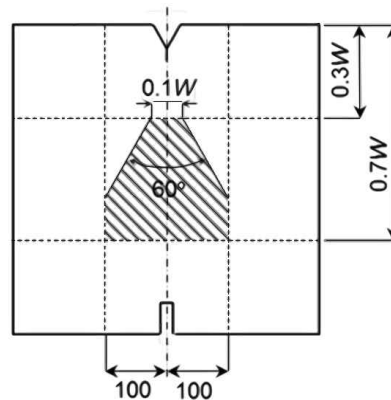


Fig 2.1.10 Allowable range of main crack propagation path

- (C) Fracture surface examination, crack length measurement and their validation
- Fracture surface shall be observed and examined. The crack “initiation” and “propagation” are to be checked for validity and judgements recorded. The crack “arrest” positions are to be measured and recorded.
  - When crack initiation trigger point is clearly detected at side groove root, other than the V-notch tip, the test shall be invalid.
  - In EBW embrittlement setting, EBW zone length is quantified by three measurements of  $L_{EB-s1}$ ,  $L_{EB-s2}$  and  $L_{EB-min}$ , which are defined in 4.5. When either or both of  $L_{EB-s1}$  and  $L_{EB-s2}$  are smaller than 150mm, the test shall be invalid. When  $L_{EB-min}$  is smaller than  $150\text{mm}-0.2t$ , the test shall be invalid.
  - When the shear lip with thickness over 1 mm in either side near side surfaces of embrittled zone are visibly observed independent of the specimens with or without side grooves, the test shall be invalid.
  - In EBW embrittlement setting, the penetration of brittle crack beyond the EBW front line shall be visually examined. When any brittle fracture appearance area continued from the EB front line is not detected, the test shall be invalid.
  - The weld defects in EBW embrittled zone shall be visually examined. If detected, it shall be quantified. A projecting length of defect on the thickness line through EB weld region along brittle crack path shall be measured, and the total occupation ratio of the projected defect part to the total thickness is defined as defect line fraction (See Fig 2.1.11 of the Guidance). When the defects line fraction is larger than 10 %, the test shall be invalid.

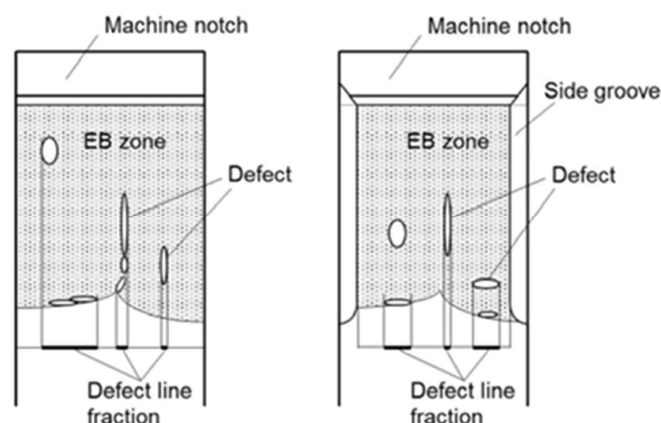


Fig 2.1.11 Counting procedure of defect line fraction

- In EBW embrittlement by dual sides' penetration, a gap on embrittled zone fracture surface which is induced by miss meeting of dual fusion lines is visibly detected at an overlapped line of dual side penetration, the test shall be invalid.



- (7) Judgement of “arrest” or “propagate”  
The final test judgment of “arrest”, “propagate” or “invalid” is decided by the following requirements of (A) through (E).
- (A) If initiated brittle crack is arrested and the tested specimen is not broken into two pieces, the fracture surfaces should be exposed with the procedures specified in **ISO 20064:2019 (2024)**
  - (B) When the specimen was not broken into two pieces during testing, the arrested crack length,  $a_{arrest}$  shall be measured on the fractured surfaces. The length from the specimen edge of impact side to the arrested crack tip (the longest position) is defined as  $a_{arrest}$ .
  - (C) For LTG and EBW,  $a_{arrest}$  shall be greater than  $L_{LTG}$  and  $L_{EB-s1}$ ,  $L_{EB-s2}$  or  $L_{EB-min}$ . If not, the test shall be considered as invalid.
  - (D) Even when the specimen was broken into two pieces during testing, it can be considered as “arrest” when brittle crack re-initiation is clearly evident. Even in the fracture surface all occupied by brittle fracture, when a part of brittle crack surface from embrittled zone is continuously surrounded by thin ductile tear line, the test can be judged as re-initiation behaviour. If so, the maximum crack length of the part surrounded tear line can be measured as  $a_{arrest}$ . If re-initiation is not visibly evident, the test is judged as “propagate”.
  - (E) The test is judged as “arrest” when the value of  $a_{arrest}$  is no greater than 0.7W. If not, the test is judged as “propagate”.
- (8)  $T_{test}$ ,  $T_{arrest}$  and CAT determination
- (A)  $T_{test}$  determination
    - (a) It shall be ensured on the thermocouple measured record that all temperature measurements across the range of 0.3W~0.7W in both width and longitudinal direction are in the range of  $T_{target} \pm 2^\circ\text{C}$  at brittle crack initiation. If not, the test shall be invalid. However, the temperature measurement at 0.3W (location of  $A_3$  and  $B_3$ ) in LTG system shall be exempted from this requirement.
    - (b) If  $L_{EB-min}$  in EBW embrittlement is no smaller than 150mm,  $T_{test}$  can be defined to equal with  $T_{target}$ . If not,  $T_{test}$  shall be equalled with  $T_{target} + 5^\circ\text{C}$ .
    - (c) In LTG embrittlement,  $T_{test}$  can be equalled with  $T_{target}$ .
    - (d) The final arrest judgment at  $T_{test}$  is concluded by at least two tests at the same test condition which are judged as “arrest”.
  - (B)  $T_{arrest}$  determination  
When at least repeated two “arrest” tests appear at the same  $T_{target}$ , brittle crack arrest behaviour at  $T_{target}$  will be decided ( $T_{arrest} = T_{target}$ ). When a “propagate” test result is included in the multiple test results at the same  $T_{target}$ , the  $T_{target}$  cannot to be decided as  $T_{arrest}$ .
  - (C) CAT determination
    - (a) When CAT is determined, one “propagate” test is needed in addition to two “arrest” tests. The target test temperature,  $T_{target}$  for “propagate” test is recommended to select  $5^\circ\text{C}$  lower than  $T_{arrest}$ . The minimum temperature of  $T_{arrest}$  is determined as CAT.
    - (b) With only the “arrest” tests, without “propagation” test, it is decided only that CAT is lower than  $T_{test}$  in the two “arrest” tests, i.e. not deterministic CAT.
- (9) Reporting  
The following items are to be reported.
- (A) Test material: grade and thickness
  - (B) Test machine capacity
  - (C) Test specimen dimensions: thickness t; width W and length L; notch details and length  $a_{MN}$ , side groove details if machined
  - (D) Embrittled zone type: EBW or LTG embrittlement
  - (E) Integrated specimen dimensions: Tab plate thickness, tab plate width, integrated specimen unit length including the tab plates, and distance between the loading pins, angular distortion and linear misalignment
  - (F) Brittle crack trigger information: impact type or double tension. If impact type, drop weight type or air gun type, and applied impact energy.
  - (G) Test conditions; Applied load; preload stress, test stress
    - Judgements for preload stress limit, hold time requirement under steady test stress.
  - (H) Test temperature: complete temperature records with thermocouple positions for measured temperatures (figure and/or table) and target test temperature.
    - Judgements for temperature scatter limit in isothermal region.
    - Judgement for local temperature gradient requirements and holding time requirement after

- steady local temperature gradient before brittle crack trigger, if LTG system is used.
- (I) Crack path and fracture surface: tested specimen photos showing fracture surfaces on both sides and crack path side view; Mark at “embrittled zone tip” and “arrest” positions.
- Judgment for crack path requirement.
  - Judgment for cleavage trigger location (whether side groove edge or V-notch edge).
- (J) Embrittled zone information:
- (a) When EBW is used:  $L_{EB-s1}$ ,  $L_{EB-s2}$  and  $L_{EB-min}$
- Judgment for shear lip thickness requirement
  - Judgment whether brittle fracture appearance area continues from the EBW front line
  - Judgment for EBW defects requirement
  - Judgment for EBW lengths,  $L_{EB-s1}$ ,  $L_{EB-s2}$  and  $L_{EB-min}$  requirements
- (b) When LTG is used:  $L_{LTG}$
- Judgment for shear lip thickness requirement
- (c) Test results:
- (i) When the specimen did not break into two pieces after brittle crack trigger, arrested crack length  $a_{arrest}$
- (ii) When the specimen broke into two pieces after brittle crack trigger,
- judgement whether brittle crack re-initiation or not.
- (iii) If so, arrested crack length  $a_{arrest}$ :
- Judgment for  $a_{arrest}$  in the valid range ( $0.3W < a_{arrest} \leq 0.7W$ )
  - Final judgement either “arrest”, “propagate” or “invalid”
- (K) Dynamic measurement results: History of crack propagation velocity, and strain change at pin chucks, if needed

## Section 3 Rolled Steels

### 301. Rolled steels for hull structural

#### 1. Application

In application to **301. 1** (4) of the Rules, the term "the discretion of the Society" means the acceptance in accordance with **Pt 1, Ch 1, 105.** of the Rules. **【See Rule】**

#### 2. Manufacturing process

- (1) The term of "thermo-mechanical controlled processing(*TMCP*)" in **301. 3** (2) of the Rules is defined in the following **3** of this Guidance. **【See Rule】**
- (2) The carbon equivalent value for higher strength steels supplied in *TMCP* condition in Remarks (13) to **Table 2.1.6** of **301. 3** of the Rules is to comply with the requirements of **Table 2.1.5** of the Guidance. **【See Rule】**

**Table 2.1.5 Carbon Equivalent of Higher Strength Steels supplied in TMCP Condition**

Grade	Carbon Equivalent( <i>Ceq</i> ) <sup>(1)</sup>	
	$t \leq 50$ mm	$50 < t \leq 100$ mm
<i>AH32, DH32, EH32, FH32</i>	0.36 max.	0.38 max.
<i>AH36, DH36, EH36, FH36</i>	0.38 max.	0.40 max.
<i>AH40, DH40, EH40, FH40</i>	0.40 max.	0.42 max.

Note:  
(1)  $C_{eq} = C + \frac{Mn}{6} + \frac{Cr + Mo + V}{5} + \frac{Ni + Cu}{15}$  (%) (2017)

- (3) The cold cracking susceptibility ( $P_{cm}$ ) calculated by following a formula instead of carbon equivalent of previous (2) may be required to be submitted when deemed necessary by the Society.

$$P_{cm} = C + \frac{Si}{30} + \frac{Mn}{20} + \frac{Cu}{20} + \frac{Ni}{60} + \frac{Cr}{20} + \frac{Mo}{15} + \frac{V}{10} + 5B$$

#### 3. Heat treatment

The definition of heat treatment mentioned in Remarks (1) to **Table 2.1.8** and **Table 2.1.9** of **301. 4** of the Rules are as follows : (Refer to **Fig 2.1.12** of the Guidance) **【See Rule】**

##### (1) As rolled, AR (2018)

This procedure involves steel being cooled as it is rolled with no further heat treatment. The rolling and finishing temperatures are typically in the austenite recrystallization region and above the normalising temperature. The strength and toughness properties of steel produced by this process are generally less than steel heat treated after rolling or than steel produced by advanced processes.

##### (2) Normalising, N (2018)

Normalising involves heating rolled steel above the critical temperature,  $A_{C3}$ , and in the lower end of the austenite recrystallization region for a specific period of time, followed by air cooling. The process improves the mechanical properties of as rolled steel by refining the grain size and homogenising the microstructure.

##### (3) Controlled Rolling(Normalising Rolling), CR(NR) (2018)

A rolling procedure in which the final deformation is carried out in the normalising temperature range, allowed to cool in air, resulting in a material condition generally equivalent to that obtained by normalising.

##### (4) Quenching and Tempering, QT (2018)

Quenching involves a heat treatment process in which steel is heated to an appropriate temperature above the  $A_{C3}$ , held for a specific period of time, and then cooled with an appropriate coolant for the purpose of hardening the microstructure. Tempering subsequent to quenching is a process in which the steel is reheated to an appropriate temperature not higher than the  $A_{C1}$ ,



- (C) In case where the result does not comply with the specifications, retests for the lot of steel material to which the failed specimens are belonging may be carried out in accordance with the requirements in **301. 10** of the Rules.
- (D) Where the result of the retest does not comply with the requirements, impact tests provided in **Tables 2.1.8** and **2.1.9** of **301. 6** of the Rules are to be carried out for all the steels manufactured thereafter. Where the test results during 6 months are confirmed as being satisfactory, the procedure specified in (B) above may be applied again.
- (E) Every manufacturer is to submit the annual report compiling the results of the impact tests to the Society.

#### 5. Surface inspection and verification of dimensions

The application to **301. 8** of the Rules is to be in accordance with the follows : **[See Rule]**

- (1) The Society may require the surface inspection of rolled steels to confirm in compliance with the quality same as that of those days of approval of the manufacturing process.
- (2) Criteria of surface inspection for flaw, pin hole and blow hole of steel plate is to comply with *KS D0208* (Method of macro-streak-flaw test for steel).
- (3) Tolerance for rolled steel other than under thickness tolerance for plate is to comply with *KS D 3051*(Dimensions weight and permissible variations of hot rolled steel bar in coil), *KS D 3052*(Shape, dimensions, weight and tolerance of hot rolled steel flats), *KS D3500* (Dimensions weight and permissible variations of hot rolled steel plates, sheets and strips) and *KS D3502* (Dimensions, weight and tolerances of hot rolled steel sections).

#### 6. Quality and repair of defects

- (1) Ultrasonic test procedures and acceptance criteria, specified in **301. 9** (3) of the Rules, are to be in accordance with either *EN 10160 Level S1/E1*, *ASTM A 578 Level C* or accepted standard at the discretion of the Society. **[See Rule]**

#### 7. Forming

The cold deformation limit specified in **301. 12** of the Rules are to be dealt with as follows :

**[See Rule]**

- (1) For steels in structural members, the cold deformation rate shall be less than 10 %.(the inside bending radius shall not be less than 4.5 times the plate thickness)
- (2) Where steels are subjected to the permanent deformation exceeding 10 %, an additional test may be required by the Society.
- (3) The use of hammering is not to be employed.

### 302. Rolled steel plates for boilers

#### 1. Selection of test samples

In application to **302. 6** of the Rules, selections of test samples in case that where the purchasers carry out normalizing specified in **302. 3** (2) of the Rules at their factories are to comply with the following requirements : **[See Rule]**

- (1) The manufacturer is to carry out normalizing of the test sample conforming to the requirements by the purchaser. Where no requirements have been given by the purchaser, the manufacturer may carry out normalizing as considered preferable. In this case, the manufacturer is to inform the purchaser the conditions of normalizing which had been carried out.
- (2) The test samples is taken from the steel plates normalized at purchasers factory or normalized together with the steel plates simultaneously.
- (3) The mechanical properties obtained by the test specimens specified in (1) and (2) above are to comply with the provisions in **Table 2.1.12** of the Rules.

#### 2. Marking

The markings related to the heat treatment of the steel plates provided in **302. 1** of the Rules are to be "TN" showing the case where normalizing is carried out for test samples only.

### 303. Rolled steel plates for pressure vessels

#### 1. Selection of test samples

In application to **303. 6** of the Rules, selections of test samples in case that where the purchasers carry out normalizing specified in **303. 3 (2)** of the Rules at their factories are to comply with the following requirements : **【See Rule】**

- (1) The manufacturer is to carry out normalizing of the test sample conforming to the requirements by the purchaser. Where no requirements have been given by the purchaser, the manufacturer may carry out normalizing as considered preferable. In this case, the manufacturer is to inform the purchaser the conditions of normalizing which had been carried out.
- (2) The test samples is taken from the steel plates normalized at purchasers factory or normalized together with the steel plates simultaneously.
- (3) The mechanical properties obtained by the test specimens specified in (1) and (2) above are to comply with the provisions in **Table 2.1.15** of the Rules.

#### 2. In **303. 7 (2)** of the Rules, the application to "deemed necessary by the Society" is to be in accordance with the follows : **【See Rule】**

- (1) Where the steel plates are used for spherical tanks or end plates, etc. of cylindrical tanks to contain cold liquefied gas at normal temperature, the impact test specimens are to be taken with their longitudinal axis normal (T direction) to the final direction of rolling.
- (2) In previous (1), the specified values of the impact tests are to be in accordance with **Table 2.1.15** of the Rules.

#### 3. Marking

The markings related to heat treatments of the steel plates provided in **303. 1** of the Guidance are to be "TV" showing case where normalising is carried out for test samples only.

#### 4. Chemical composition

In application to note (1) and (2), **Table 2.1.14-1** of **303. 4** of the Rules, the term "deemed appropriate by the Society" means the acceptance in accordance with **Pt 1, Ch 1, 105.** of the Rules. **【See Rule】**

### 304. Rolled steels for low temperature service

In application to **304. 1 (2)** of the Rules, the term "the discretion of the Society" means the acceptance in accordance with **Pt 1, Ch 1, 105.** of the Rules. **【See Rule】**

### 305. Rolled stainless steels

#### 1. Application

In application to **305. 1 (2)** of the Rules, the grade, chemical composition and mechanical properties of austenitic-ferritic stainless steel (hereinafter referred to as "duplex stainless steels") not exceeding 75 mm in thickness are to be as specified on the followings. **【See Rule】**

##### (1) Grades and chemical composition

The grade and chemical composition of duplex stainless steels are to comply with the provisions in **Table 2.1.6** of the Guidance.

**Table 2.1.6 Grades and chemical composition (2018)**

Grade	Chemical composition(%)								
	C	Si	Mn	P	S	Ni	Cr	Mo	N
RSTS31803	0.030	1.00	2.00	0.035	0.015	4.5~6.5	21.0~23.0	2.5~3.5	0.10~0.22
RSTS32750	max.	max.	max.	max.	max.	6.0~8.0	24.0~26.0	3.0~4.5	0.24~0.35

##### (2) Mechanical properties

The mechanical properties of duplex stainless steels are to comply with the provisions in **Table 2.1.7** of the Guidance.

Table 2.1.7 Mechanical properties (2017)(2018)

Grade	Tensile test			Impact test		
	Yield strength (N/mm <sup>2</sup> )	Tensile strength (N/mm <sup>2</sup> )	Elongation(%) ( $L = 5.65\sqrt{A}$ )	Test temp. (°C)	Average absorbed energy(J)	
					L	T
RSTS31803	460 min.	640 min.	25 min.	- 20	41 min.	27 min.
RSTS32750	530 min.	730 min.	25 min.			

## 2. Forming

The deformation limit specified in **305. 10** of the Rules are to be dealt with as follows : **【See Rule】**

(1) For rolled stainless steels in structural members, the deformation rate shall be less than 20 %.  
(the inside bending radius shall not be less than 2 times the plate thickness)

3. "deemed necessary by the Society" referred in **305. 5** (4) of the Rules means where steels have properties with corrosion resistance or additional toughness. **【See Rule】**

## 306. Round bars for chain

Round bars for offshore mooring chain are to comply with **Annex 2-9, 2** of this guidance. **【See Rule】**

## 307. Rolled steel bars for boiler

In application to **307. 3** of the Rules, the term "deemed necessary by the Society" means the acceptance in accordance with **Pt 1, Ch 1, 105.** of the Rules. **【See Rule】**

## 308. High Strength Steels for Welded Structures

1. In application to **308. 1** (2) of the Rules, the term "the discretion of the Society" means the acceptance in accordance with **Pt 1, Ch 1, 105.** of the Rules. **【See Rule】**

### 2. Manufacturing process (2017)

(1) In application to **308. 3** (4) of the Rules, a fine grain structure has an equivalent index  $\geq 6$  determined by micrographic examination in accordance with **ISO 643** or alternative test method. **【See Rule】**

(2) In application to **308. 3** (6) of the Rules, products can be susceptible to deterioration in mechanical strength and toughness if they are subjected to incorrect post-weld heat treatment procedures or other processes involving heating such as flame straightening, rerolling, etc. where the heating temperature and the holding time exceed the limits given by the manufacturer.

3. In application to **308. 6** (2) of the Rules, the term "deemed appropriate by the Society" means the acceptance in accordance with **Pt 1, Ch 1, 105.** of the Rules. **【See Rule】**

### 4. Selection of test samples (2017) **【See Rule】**

(1) In application to **308. 7** (1) and (2) (c) of the Rules, if the mass of the finished material is greater than 25 tonnes, one set of tests from each 25 tonnes and/or fraction thereof is required. (e.g. for consignment of 60 tonnes would require 3 plates to be tested).

(2) For continuous heat treated product special consideration may be given to the number and location of test specimens required by the manufacturer to be agreed by the Society.

## 309. Stainless clad steel plates

### 1. Mechanical properties

Shearing strength test method complies with *KS D0234*.(Testing methods for clad steel) **【See Rule】**

### 2. Quality and repair of defects

Ultrasonic test generally complies with *KS D3693* (Stainless-clad steel) and *KS D0234*.(Testing methods for clad steel) **【See Rule】**

3. In application to **309. 2 (2)** and **8** of the Rules, the term "the discretion of the Society" means the acceptance in accordance with **Pt 1, Ch 1, 105.** of the Rules. **[See Rule]**
4. "deemed necessary by the Society" referred in **309. 5 (2)** of the Rules means where plates have properties with corrosion resistance, etc. **[See Rule]**

### 310. Additional requirements for through thickness properties

#### 1. Application

"deemed appropriate by the Society" referred in **310. 1 (2)** of the Rules means where the other steels than the material specified in **310. 1 (1)** of the Rules are required improved through thickness properties. **[See Rule]**

#### 2. Selection of test specimens

In application to **310. 5 (1)** of the Rules, the term "round tensile test specimens" means where specimens are to be accepted in accordance with **Pt 1, Ch 1, 105.** of the Rules.

#### 3. Ultrasonic tests

- (1) Ultrasonic test procedures and acceptance criteria, specified in **310. 7 (2)** of the Rules, are to be in accordance with either *EN 10160:1999 Level S1/E1*, *ASTM A 578:2017 Level C* or accepted standard at the discretion of the Society (2023) **[See Rule]**

### 312. Brittle crack arrest steels (2021)

#### 1. Brittle crack arrest properties

- (1) The  $K_{ca}$  value in **Table 2.1.45** Note (3) of **312.** of the Rules are obtained by performing a brittle crack arrest test in accordance with **Pt 2, Ch 1, 203. 1.** of the Guidance. **[See Rule]**
- (2) The CAT in **Table 2.1.45** Note (4) of **312.** of the Rules are obtained by performing a test in accordance with **Pt 2, Ch 1, 203. 4.** of the Guidance. **[See Rule]**

#### 2. Approval Scheme of Small-scale Test Methods for Brittle Crack Arrest Steels (2024)

- (1) Scope
  - (A) These requirements specify the approval scheme of small-scale test methods which are used for product testing (batch release testing) of brittle crack arrest steels specified as **Table 2.1.45** Note (6) of **312.** of the Rules.
  - (B) Unless otherwise specified in these requirements, **Pt 2, Ch 1, 203. 1.** and **2.** of the Guidance are to be followed.
- (2) Approval Application
  - (A) The manufacturer is to submit to the Society the following documents.
    - (a) Application for approval of small-scale test procedure specification
    - (b) Small-scale test procedure specification including the following items at least
      - (i) Applicable material grades, thickness range, deoxidation practice, heat treatment, etc.
      - (ii) Types and methods of small-scale tests
      - (iii) Sampling positions in plate thickness direction and final rolling direction of test specimens
      - (iv) Size and dimension of test specimens
      - (v) Number of test specimens
      - (vi) Test conditions, such as test temperature
      - (vii) Acceptance criterion
      - (viii) Example of format of test report
      - (ix) Example of product inspection certificate including small-scale test results
      - (x) Handling of the products when small-scale test results do not satisfy the criterion
    - (c) Mechanism of achieving the brittle crack arrest properties of brittle crack arrest steels
    - (d) Technical background for enabling the evaluation of brittle crack arrest properties by small-scale test methods considering the mechanism specified in above (c).
    - (e) Procedure of the evaluation for the brittle crack arrest properties of brittle crack arrest steels by small-scale test results.
    - (f) Data records which validate the correlation between small-scale test results and the large brittle crack arrest test results of brittle crack arrest steels whose number can satisfy



- the requirement for minimum data number given in (3) (C).
- (g) Proposed test plan for approval
  - (B) Small-scale test procedure specification is to be prepared in accordance with (3).
  - (C) Where the manufacturer proposes to change any part of the approved small-scale test procedure specification, then the manufacturer is to submit to the Society the documents which can cover all items specified in 2. (2) (A).
  - (D) The documents confirming the reason for the change shall be submitted to identify the impact of those changes on the existing procedure, and the proposed actions to address any such impacts.
- (3) Establishment of Procedure Specification for Small-scale Testing
- (A) General
    - (a) Small-scale test methods are to be determined based on the manufacturer's own technical philosophy with regard to achieving the brittle crack arrest properties of brittle crack arrest steels. Furthermore, description of an appropriate correlation between large scale brittle crack arrest properties and small-scale test results is to be required, and the acceptance criterion of the small-scale test are to be determined, based on the followings.
      - (i) Mechanism of achieving the suitable brittle crack arrest properties
      - (ii) Sampling position and direction
      - (iii) Frequency of sampling
      - (iv) Small-scale test methodology
      - (v) Demonstrated correlation between brittle crack arrest test results and small-scale test results
      - (vi) Derivation of small scale testing acceptance criterion based on the statistical analysis
    - (b) The manufacturer shall prepare the small-scale test procedure specification in accordance with the following (B) through (E).
  - (B) Types and Methods of Testing
    - (a) Types, methods, dimension and positions as well as direction of test specimens, etc. of small-scale tests are to be specified by the manufacturer, and approved in accordance with these requirements.
    - (b) In general, the test method should reproduce the crack initiation, propagation and arrest feature by such as the following test method.
      - (i) Combination of test methods, e.g. NRL drop weight test and V-notch Charpy impact test
      - (ii) One test method, e.g. press-notch Charpy impact test or side-section drop weight test
    - (c) In general, brittle crack arrest properties of brittle crack arrest steels are to be predicted using a regression equation on the relationship between small scale test result (e.g. transition temperature obtained by small scale tests) and large scale brittle crack arrest test result (e.g.  $K_{ca}$  or temperature corresponding to the specific brittle crack arrest properties). Other approaches can be used subject to the approval of the Society.(NOTE: **Table 2.1.8**, **Table 2.1.9** and **Table 2.1.10** give the examples of small scale test methods.
    - (d) For determination of test methods, the manufacturer should confirm the applicability of these test methods to their brittle crack arrest steels theoretically taking into account the methodology of test methods, their own mechanism of achieving the brittle crack arrest properties, and sampling positions of test specimens (See (A) (a)). Then, the manufacturer should also submit the technical background for determination of small-scale test methods to the Society as given in (2) (A).
  - (C) Testing Data
    - (a) Selection of test plates
      - (i) Brittle crack arrest tests and small-scale tests are to be conducted for each material grade (including all suffixes) of brittle crack arrest steels in accordance with (C).
      - (ii) Brittle crack arrest tests and small-scale tests are to be carried out on at least 12 test plates, in accordance with (iii), by which these test results can reliably estimate brittle crack arrest properties of brittle crack arrest steels.(NOTE: "One test plate" means "the rolled product from a single slab or ingot if this is rolled directly into plates")
      - (iii) In order to ensure appropriate correlation between small-scale test results and brittle crack arrest properties with various manufacturing conditions of steel plates, the steel plates should be representative for each combination of thickness range and heat

sample to include:

- The intended maximum and minimum plate thickness;
- Different heats are to be chosen for each thickness

Furthermore, the above test plates are to include a fixed number of steel plate(s) whose brittle crack arrest properties (i.e. brittle crack arrest test results) do not comply with the requirements specified in **Table 2.1.45** of **Pt 2, Ch 1, 312.** of the Rules. Such a number should be at least one, but not exceeding one quarter of all test plates. Manufacturing process of these test plates can be different (or intentionally altered from the approved manufacturing process) from that of the brittle crack arrest steels to which the small-scale test method is applied. It is recommended that the strength grade of these test plates (non-compliant with the relevant requirements of brittle crack arrest properties) are similar to that of the brittle crack arrest steels.

Where the manufacturer has requested approval for only a single thickness, the thickness of test plates can be only a single thickness. In this case, at least four steel plates for each combination of thickness (single thickness) and heats (three different heats) should be used, and the applicable thickness of the small scale test is only that single thickness condition.

- (iv) Brittle crack arrest steels used for the approval test of manufacturing process of these steels (and its approval test results) can also be used as the test plates specified in (iii).
- (v) Brittle crack arrest test specimens and small-scale test specimens are to be taken from the same test plate.
- (vi) A decrease of the total of the indicated number of test plates may be accepted by the Society in the following ① or ② cases:
  - ① When the manufacturer applies a small-scale test procedure specification to multiple material grades, and the manufacturing process and mechanism to ensure the brittle crack arrest properties of these different material grades are the same.
  - ② When a small-scale test procedure specification is already approved by the Society for one or some material grades, and the manufacturer applies similar small-scale test procedure specification to the other material grade(s), and the manufacturing process and mechanism to ensure the brittle crack arrest properties of these different material grades are same.
- (b) Brittle crack arrest tests
  - (i) Brittle crack arrest tests are to be carried out for each test plate in accordance with **Ch. 2, Sec. 2-8** of the **Guidance for Approval of Manufacturing Process and Type Approval, Etc..**
  - (ii) Where brittle crack arrest tests are carried out for evaluation of  $K_{ca}$ ,  $K_{ca}$  at a specific temperature is to be obtained in accordance with **203. 1. (3)** of the Guidance.
  - (iii) Where brittle crack arrest tests are carried out for evaluation of CAT, deterministic (actual) CAT is to be obtained in accordance with **203. 2. (8) (C)** of the Guidance.
- (c) Small-scale tests
  - (i) Small-scale tests are to be carried out in accordance with small-scale test procedure specification to be approved for each test plate.
  - (ii) In general, the test specimens of small-scale tests are to be taken with their longitudinal axis parallel to the final rolling direction of the test plates.
  - (iii) The test specimens of small-scale tests are to be taken from the specified positions in plate thickness direction of the test plates, as given in (B) (c).
- (D) Validation of Correlation
  - (a) A regression equation on the relationship between brittle crack arrest property obtained from brittle crack arrest test and single or multiple small-scale test results is to be established. For brittle crack arrest properties, a specific temperature (e.g.  $T_{K_{ca}6000}$  in BCA1,  $T_{K_{ca}8000}$  in BCA2 or CAT) or the  $K_{ca}$  value at  $-10^{\circ}\text{C}$  may be used.
  - (b) The validity of the regression equation shall be examined to predict brittle crack arrest properties with enough accuracy. The correlation in brittle crack arrest properties between the calculated values from small scale tests and the brittle crack arrest test results shall be assured by using the value of twice the standard deviation ( $2\sigma$ ). When using temperature for brittle crack arrest property,  $2\sigma$  shall not be greater than  $20^{\circ}\text{C}$ . In other cases (e.g.  $K_{ca}$  value at  $-10^{\circ}\text{C}$ ), an upper limit of  $2\sigma$  shall be established with the agreement

of the Society.  
Calculation procedure of the standard deviation ( $\sigma$ ) is given as follows:

$$\sigma = \sqrt{\frac{1}{(n-1)} \sum_{i=1}^n (y_i - x_i)^2}$$

n: number of test plates

$y_i$ : brittle crack arrest property obtained from brittle crack arrest test for one test plate

$x_i$ : brittle crack arrest property estimated from small scale tests for one test plate

(E) Acceptance Criterion

(a) Acceptance criterion of brittle crack arrest steels by the small-scale tests is to be proposed by the manufacturer based on the regression equation which is assured in the correlation with brittle crack arrest properties in (D) above. The criterion is to be determined so that regression equation can predict brittle crack arrest properties on safety side, considering the scatter of brittle crack arrest properties from the predicted value by the regression equation.

(b) Unless otherwise agreed by the Society, an acceptance criterion of small-scale tests is to be determined by following procedures.

(i) For correlation by means of temperature

Ⓐ The required temperature (see Fig 2.1.13) is obtained by subtracting  $2\sigma$ (°C) from the brittle crack arrest steel specification in Table 2.1.45 of Pt 2, Ch 1, 312. of the Rules, that is  $-10-2\sigma$ (°C), where  $2\sigma$  is given in (D) (b).

$T_{Kca6000}$  and  $T_{Kca8000}$  in Fig 2.1.13 are the temperatures at which the  $K_{ca}$  value of steel plates equals  $6000N/mm^{3/2}$  and  $8000N/mm^{3/2}$ , respectively.

Ⓑ The temperature predicted from the small-scale test results through the regression equation shall be no higher than the value of  $-10-2\sigma$ (°C).

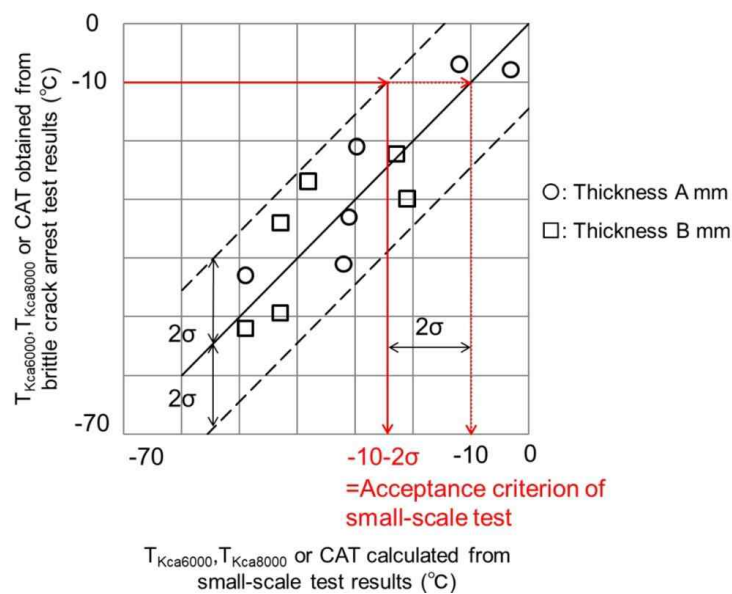


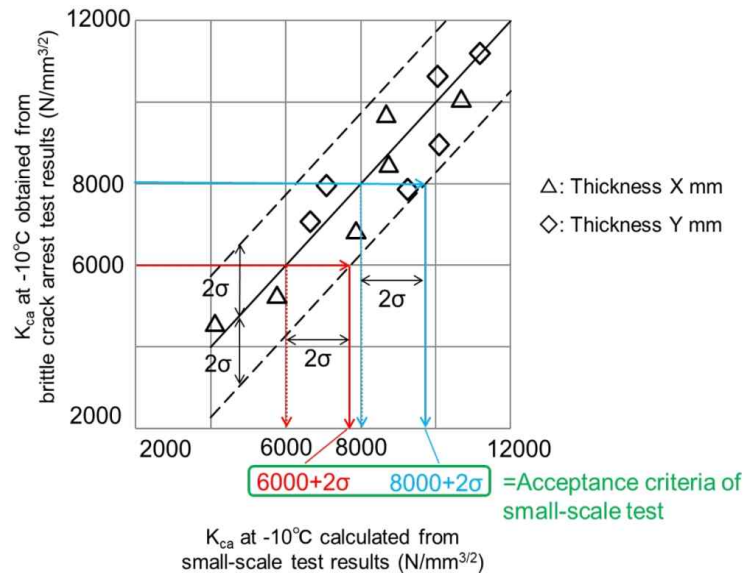
Fig 2.1.13 Example for determination of acceptance criterion of small-scale test for correlation by means of temperature

(Note: This is only a schematic and may not represent the actual data obtained)

(ii) For correlation by means of brittle crack arrest toughness ( $K_{ca}$ ):

Ⓐ The required  $K_{ca}$  (see Fig 2.1.14) is obtained by adding  $2\sigma$  ( $N/mm^{3/2}$ ) to the brittle crack arrest steel specification in Table 2.1.45 of Pt 2, Ch 1, 312. of the Rules, that is either  $6,000+2\sigma(N/mm^{3/2})$  in BCA1 or  $8,000+2\sigma(N/mm^{3/2})$  in BCA2, where  $2\sigma$  is given in (D) (b).

- ⑥ The  $K_{ca}$  value predicted from the small-scale test results through the regression equation shall be no smaller than the value of  $6000+2\sigma(N/mm^{3/2})$  for BCA1, or  $8000+2\sigma(N/mm^{3/2})$  for BCA2.



**Fig 2.1.14 Example for determination of acceptance criteria of small-scale test for correlation by means of brittle crack arrest toughness ( $K_{ca}$ )**  
(Note: This is only a schematic and may not represent the actual data obtained)

(4) Approval Tests

(A) General

- (a) In order to confirm the validity of the submitted technical documents specified in (2) (A), approval tests are to be carried out.
- (b) Approval test plan is to be approved by the Society prior to testing.
- (c) Considering the contents of the submitted technical documents specified in (2) (A), the Society may require additional tests in the following cases:
  - (i) When the Society determines that the number of brittle crack arrest tests or small-scale tests is too few to adequately confirm the validity of the acceptance criterion of small-scale tests (See (3) (C) (a));
  - (ii) When the Society determines that the testing data obtained for setting the acceptance criterion of small-scale tests varies too widely (See (3) (D) (b)), or that the data is clustered producing a biased correlation curve;
  - (iii) When the Society determines that the validity of brittle crack arrest test results or small-scale test results for setting the acceptance criterion of small-scale tests is insufficient, or has some flaws during tests and/or for test results (See (3) (C) (b) and (3) (C) (c)); and
  - (iv) Others as deemed necessary by the Society.

(B) Extent of the approval tests

Extent of the approval tests is to be in accordance with extent of the approval tests for approval of manufacturing process.

(C) Type of tests

(a) Brittle crack arrest tests

- (i) Brittle crack arrest tests are to be carried out in accordance with **Ch. 2, Sec. 2-8, 3.** (1) of the **Guidance for Approval of Manufacturing Process and Type Approval, Etc..**

- (ii) Where brittle crack arrest tests are carried out for evaluation of  $K_{ca}$ ,  $K_{ca}$  at a specific temperature ( $T_{Kca6000}$  or  $T_{Kca8000}$ ) is to be obtained in accordance with **Pt 2, Ch 1, 203. 1. (3)** of the Guidance.
- (iii) Where brittle crack arrest tests are carried out for evaluation of CAT, deterministic CAT is to be obtained in accordance with **Pt 2, Ch 1, 203. 2. (8) (C)** of the Guidance.
- (b) Small-scale tests  
Small-scale tests are to be carried out in accordance with (3) (C) (c).
- (5) Results
  - (A) Results of test items and the procedures shall comply with the test program approved by the Society.
  - (B) For the brittle crack arrest test results, the manufacturer is to submit to the Society the brittle crack arrest test reports in accordance with **Pt 2, Ch 1, 203. 1.** of the Guidance for  $K_{ca}$  and **Pt 2, Ch 1, 203. 2.** of the Guidance for CAT.
  - (C) For small-scale test results, the manufacturer is to submit to the Society the small-scale test reports in accordance with the example of format of test reports submitted as specified in (2) (A) (b).
- (6) Approval  
Upon satisfactory completion of the survey and tests, and satisfactory confirmation of the submitted technical documents, the approval for small scale test procedure specification is granted by the Society.

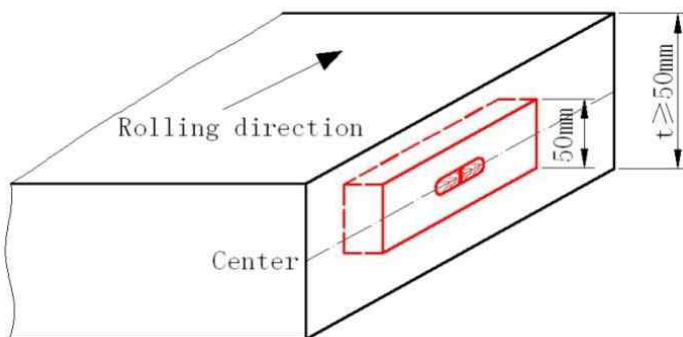
**Table 2.1.8 Example of small-scale test method using NRL drop weight test and V-notch Charpy impact test (Informative)**

Test type	NRL drop weight test and V-notch Charpy impact test
Standard	<b>ASTM E208:2020</b> and <b>ISO 148-1:2016</b>
Sampling positions of test specimens	NRL drop weight test: at surface V-notch charpy impact test: 1/4 of thickness
Length direction of test specimen :	Parallel to the final rolling direction of test plate
Regression equation	$T_{Kca} = \alpha \cdot (NDTT + 10) + \beta \cdot v Trs + 153(t - 5)^{1/13} - 170.5$ <p> <math>T_{Kca}</math> : Temperature at <math>K_{ca}</math> of <math>6000N/mm^{3/2}</math> or <math>K_{ca}</math> of <math>8000N/mm^{3/2}</math>(°C)            NDTT : Nil-ductility transition temperature (°C)  <math>v Trs</math> : Transition temperature of the absorbed energy (°C)            t: thickness  <math>\alpha, \beta^{(1)}</math> : constant         </p>
Note :	(1) $\alpha$ and $\beta$ are determined by comparing small-scale test results with brittle crack arrest test results.

**Table 2.1.9 Example of small-scale test method using pressed-notch Charpy impact test (Informative)**

Test type	Pressed-notch Charpy impact test
Standard	Dimension, shape, introducing method of notch: Manufacturer's proposal Others: <b>ISO148-1:2016</b>
Sampling position of test specimen	1/2 of thickness
Length direction of test specimen	Parallel to the final rolling direction of test plate
Regression equation	$T_{Kca} = \alpha_b T_{E\gamma J} + \beta$ <p> <math>T_{Kca}</math> : Temperature at <math>K_{ca}</math> of 6000N/mm<sup>3/2</sup> or <math>K_{ca}</math> of 8000N/mm<sup>3/2</sup>, (°C)  <math>pT_{E\gamma J}</math> : Test temperature at absorbed energy of <math>\gamma</math>(J), (°C)  <math>\alpha, \beta</math> : Constant  <math>\gamma</math> : Absorbed energy at brittle fracture surface ratio of <math>\delta</math>(%), (J)                 </p>
Note : (1) $\alpha$ , $\beta$ , $\gamma$ and $\delta$ are determined by comparing small-scale test results with brittle crack arrest test results.	

**Table 2.1.10 Example of small-scale test method using Side-section drop weight test (Informative)**

Test type	Side-section drop weight test
Standard	Dimension: P-2 type of <b>ASTM E 208 2020</b>
Sampling positions of test specimens	1/2 of thickness and side-section 
Length direction of test specimen	Parallel to the final rolling direction of test plate
Regression equation	$T_{Kca} = \alpha + \beta \cdot T_{NDT}^{side} + \gamma \cdot t^{1.5}$ <p> <math>T_{Kca}</math> : Temperature at <math>K_{ca}</math> of 6000N/mm<sup>3/2</sup> or <math>K_{ca}</math> of 8000N/mm<sup>3/2</sup>, (°C)  <math>T_{NDT}^{side}</math> : Nil-ductility transition temperature obtained by side-section drop weight test, (°C)  <math>t</math>: thickness  <math>\alpha, \beta, \gamma^{(1)}</math> : constant                 </p>
Note : (1) $\alpha$ , $\beta$ and $\gamma$ are to be determined by comparing small-scale test results with brittle crack arrest test results.	

## Section 4 Steel Tubes and Pipes

### 401. Steel tubes for boilers and heat exchangers

1. The definition of heat treatment mentioned in **Table 2.1.47** of **401. 3** of the Rules are as follows  
【See Rule】

- (1) **Low temperature annealing** : An annealing treatment which is performed to eliminate internal stress or reduce quenching strain.
- (2) **Normalizing** : Heating a ferrous alloy to a suitable temperature above  $A_3$  or  $A_{cm}$  and then cooling in still air to a temperature substantially below  $A_1$ . Is performed to refine the crystal structure and eliminate internal stress.
- (3) **Full Annealing** : An annealing treatment in which a steel is austenitized by heating to a temperature above the upper critical temperature ( $A_3$  or  $A_{cm}$ ) and then cooled slowly to room temperature.
- (4) **Isothermal Annealing** : A process in which a ferrous alloy is heated to produce a structure partly or wholly austenitic, and is then cooled to and held at a temperature that causes transformation of the austenite to a relatively soft ferrite-carbide aggregate.

### 2. Chemical composition

The chemical composition of *RSTH33* is to comply with the requirements given in **Table 2.1.11** of the Guidance. 【See Rule】

**Table 2.1.11 Chemical composition**

Grade	chemical composition (%)				
	<i>C</i>	<i>Si</i>	<i>Mn</i>	<i>P</i>	<i>S</i>
<i>RSTH33</i>	0.18max.	0.35max	0.25~0.60	0.035max	0.035max

### 3. Heat treatment and mechanical properties

- (1) The heat treatment of *RSTH33* is to be same as the requirement for *RSTH35*
- (2) The mechanical properties of *RSTH33* are to comply with the following requirements. 【See Rule】
  - (a) **Tensile test** : The tensile test of *RSTH33* is to comply with the requirements given in **Table 2.1.12** of the Guidance.

**Table 2.1.12 Mechanical properties**

Grade	Yield strength (N/mm <sup>2</sup> )	Tensile strength (N/mm <sup>2</sup> )	Elongation (%) ( $L = 5.65\sqrt{A}$ )
<i>RSTH33</i>	175 min	325 min	26(22) min

NOTES:

1. The values of elongation in parenthesis are applicable to the test specimens taken transversely. In this case, the sampling material is to be heated 600°C to 650°C after flattened and annealed in order to make it free from strain.
2. In case where test specimen of non-tubular section is taken from an electric-resistance welded steel tube, the test specimen is to be taken from the parts that do not include the welded line.

- (b) **Flattening test** : The flattening test of *RSTH33* is to comply with the requirements given in **401. 5 (2)** of the Rules. However, the value of  $e$  is to be 0.09
- (c) **Flanging test** : A section of steel tube which is taken from its end is to be turned over cold so as to have a flange, the outside diameter of which is not less than specified in **Table 2.1.13** of the Guidance, at right angle to the axis without cracking or showing flaw. In this case, the flanging test specimen is to be of length  $L$  such that after testing the remaining cylindrical portion is not less than  $0.5D$ . But, this test is to be made only for *RSTH 33* tubes having wall thickness not more than  $1/10$  of its outside diameter and not more than 5

mm.

**Table 2.1.13 Outside Diameter of Flange after Flanging**

Outside diameter of steel tube	Outside diameter of flange
Less than 63 mm	1.3 times the outside diameter of steel tube
63 mm and over	Outside diameter of steel tube + 20 mm

- (d) *Crushing test* : Where required by the Surveyor, a crushing test is to be made on a section of steel tube of 65 mm in length which is to stand crushing longitudinally without cracking or splitting to the height specified in **Table 2.1.14** of the Guidance.

**Table 2.1.14 Height of Section after Crushing**

Thickness of steel tube $t$ (mm)	Height of section after crushing
$t \leq 3.4$	19 mm or until outside folds are in contact
$t > 3.4$	32 mm

- (e) *Reverse flattening test* : The reverse flattening test of *RSTH33* is to comply with the requirements given in **401. 5** (4) of the Rules.
- (f) *Hydraulic test* : The hydraulic test of *RSTH33* is to comply with the requirements given in **401. 5** (5) of the Rules.
- (3) The non-destructive inspection, substituted for the hydraulic tests, specified in **401. 6** (4) of the Rules are to be either ultrasonic tests or eddy current tests. **【See Rule】**
- (a) Ultrasonic test is to comply with *KS D 0250* (Ultrasonic examination for steel pipes and tubes). Steel tubes and pipes not to be detected the signal equivalent to that to be detected at artificial holes of reference block from detection sensitivity UD are accepted.
- (b) Eddy current test is to comply with *KS D 0251* (Eddy current examination for steel pipes and tubes). Steel tubes and pipes not to be detected the signal equivalent to that to be detected at artificial holes of reference block from detection sensitivity EY are accepted.

#### 4. Selection of test specimen

The test specimens of *RSTH33* are to be taken in accordance with the following requirements, from each grade and each size which has been heat treated at the same time in the same heating furnace for heat-treated tubes and from each grade and each size for non-heat-treated steel tubes respectively. **【See Rule】**

- (1) *Seamless steel tubes* : One sampling steel tube is to be selected from each lot of 100 tubes or fraction thereof, and one tension, one flattening and one flanging or flaring test specimens are to be taken from each of the sampling steel tubes.
- (2) *Electric-resistance welded steel tubes* : In addition to the requirements in (1), one sampling steel tube is to be selected from each lot of 50 tubes or fraction thereof for 100 and less steel tubes, and each lot of 100 tubes or fraction thereof for 100 over steel tubes, and one reverse flattening test specimen is to be taken from each of the sampling steel tubes.

### 402. Steel pipes for pressure piping

#### 1. Mechanical properties

"The non-destructive inspection deemed appropriate by the Society" specified in **402. 6** (4) of the Rules are dealt with according to the provisions in **401. 3** (3) of the Guidance. **【See Rule】**

### 403. Stainless steel pipes (2018)

#### 1. Application

In application to **403. 1** (2) of the Rules, the grade, chemical composition and mechanical properties of duplex stainless steel pipes are to be as specified on the followings. **【See Rule】**

- (1) **Grades and chemical composition**



The grade and chemical composition of duplex stainless steels pipes are to comply with the provisions in **Table 2.1.15** of the Guidance.

**Table 2.1.15 Grades and chemical composition**

Grade	Chemical composition(%)									
	<i>C</i>	<i>Si</i>	<i>Mn</i>	<i>P</i>	<i>S</i>	<i>Ni</i>	<i>Cr</i>	<i>Mo</i>	<i>N</i>	<i>Cu</i>
<i>RSTS 31803TP</i>	0.030 max.	1.00 max.	2.00 max.	0.030 max.	0.020 max.	4.5~6.5	21.0~23.0	2.5~3.5	0.08~0.20	-
<i>RSTS 32750TP</i>	0.030 max.	0.80 max.	1.20 max.	0.035 max.	0.020 max.	6.0~8.0	24.0~26.0	3.0~5.0	0.24~0.32	0.50 max.

(2) **Mechanical properties**

The mechanical properties of duplex stainless steels are to comply with the provisions in **Table 2.1.16** of the Guidance.

**Table 2.1.16 Mechanical properties**

Grade	Tensile test			Hardness test
	Yield strength (N/mm <sup>2</sup> )	Tensile strength (N/mm <sup>2</sup> )	Elongation(%) ( $L = 5.65\sqrt{A}$ )	Brinell $H_{BW}$
<i>RSTS 31803TP</i>	450 min.	620 min.	25 min.	290 max.
<i>RSTS 32750TP</i>	550 min.	800 min.	15 min.	300 max.

**404. Steel pipes for low temperature service**

**1. Application**

In application to **404. 1 (2)** of the Rules, the term "the discretion of the Society" means the acceptance in accordance with **Pt 1, Ch 1, 105.** of the Rules. **【See Rule】**

## Section 5 Castings

### 501. Steel castings

#### 1. Chemical composition [See Rule]

(1) In application to **501. 4** of the Rules, the chemical composition of special carbon steel casting with higher toughness requirements such as high holding power anchors etc. is to comply with the requirements of **Table 2.1.17** of the Guidance.

The suitable grain refining elements such as aluminium etc. are to be used at the discretion of the manufacturer. The content of such elements is to be reported in the ladle analysis.

**Table 2.1.17 Chemical Composition**

Materials	Chemical composition (%)						
	<i>C</i>	<i>Si</i>	<i>Mn</i>	<i>P</i>	<i>S</i>	<i>Al</i>	others
Special carbon steel casting	0.23 max.	0.60 max.	1.60 max.	0.035 max.	0.035 max.	0.015~0.08	to comply with <b>Table 2.1.69</b> of the Rules

(2) "Subject to approval by the Society," referred in note (1), **Table 2.1.74** of **501. 4** of the Rules means only where welding procedure qualification test of the casting for welded construction with same chemical composition has been satisfied by the Society **[See Rule]**

#### 2. Surface and dimension inspection

The surface inspection of stern frames, rudder frames and crank shaft specified in **501. 8** of the Rules are to be dealt with as follows : **[See Rule]**

- (1) The surface inspection of stern frame and rudder frame are to comply with the **Annex 2-2**.
- (2) The surface inspection of crank shafts made of steel castings are to comply with the **Annex 2-3**.

#### 3. Non-destructive inspection

The non-destructive inspection for steel castings specified in **501. 10** (1) and (2) of the Rules are to be dealt with as follows : **[See Rule]**

- (1) The non-destructive inspection of stern frame and rudder frame are to comply with the **Annex 2-2**.
- (2) The non-destructive inspection of crank shafts made of steel castings are to comply with the **Annex 2-3**.

#### 4. Repair of defects

Repairs by welding for steel casting specified in **501. 11** (1) (ii) of the Rules are to be dealt with as follows : **[See Rule]**

- (1) Repairs by welding of crank throws made of steel castings are to comply with the **Annex 2-4**.
- (2) Repairs by welding of steel alloy castings are to comply with **7** (the preparatory tests) of the **Annex 2-4**.

## 502. Steel castings for chains

Steel castings for offshore mooring chain are to comply with **Annex 2–9, 4** of this guidance. **[See Rule]**

## 505. Stainless steel casting for propeller

### 1. Application

"agreement with the Society" referred in **505. 1** (1) of the Rules includes the possible normal operation throughout the repair of propellers damaged in service. **[See Rule]**

### 2. Non-destructive inspection

- (1) The liquid penetrant test of steel propeller casting specified in **505. 8** (1) of the Rules is to comply with **Annex 2–6**. Magnetic particle testing may be used in lieu of liquid penetrant testing for examination of martensitic stainless steels castings. Magnetic particle testing procedure is to be submitted to the Society and is to be in accordance with **ISO 9934–1:2016** or a recognized standard. The acceptance criteria is accordance with **Annex 2–6**. (2021) **[See Rule]**
- (2) The division of severity zones of steel propeller casting specified in **505. 8** (2) is to comply with the **Figs. 1** and **2** of **Annex 2–6**. **[See Rule]**

### 3. Repair of defects

In application to **505. 9** (4) of the Rules, the repair welding procedure is to comply with the followings **[See Rule]**

- (1) The limits of repair welding are to comply with **Annex 2–6, 3** (2) to (4).

#### (2) Repair welding procedure

When steel propeller casting is repaired by welding in accordance with the previous (1), the following requirements apply.

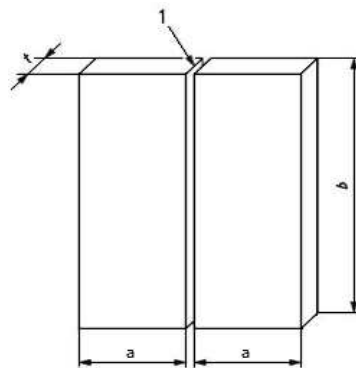
- (A) Before welding is started, manufacturer shall submit to the Society a detailed welding procedure specification covering the weld preparation, welding positions, welding parameters, welding consumables, preheating, post weld heat treatment and inspection procedures to the Society. The welding procedure qualification tests are to be carried out in accordance with following (3). (2021)
  - (B) All weld repairs are to be carried out in accordance with qualified procedures, and, by welders who are qualified to a recognized standard. Welding Procedure Qualification Tests are to be carried out in accordance with following (3) and witnessed by the Surveyor. (2021)
  - (C) Defects to be repaired by welding are to be ground to sound material according to **505. 10** of the Rules. (2021)
  - (D) The welding grooves are to be prepared in such a manner which will allow a good fusion of the groove bottom. (2021)
  - (E) The resulting ground areas are to be examined in the presence of the Surveyor by liquid penetrant testing in order to verify the complete elimination of defective material. (2021)
  - (F) Welding is to be done under controlled conditions free from draughts and adverse weather.
  - (G) The welding consumables used in the welding procedure qualification tests are to be used. The welding consumables are to be stored and handled in accordance with the manufacturer's recommendations.
  - (H) The martensitic steels are to be furnace re-tempered after weld repair. Subject to prior approval of the Society, however, local stress relieving may be considered for minor repairs.
  - (I) On completion of heat treatment the weld repairs and adjacent material are to be ground smooth. All weld repairs are to be liquid penetrant tested.
  - (J) The foundry is to maintain records of welding, subsequent heat treatment and inspections traceable to each casting repaired. These records are to be reviewed by the Surveyor.
- (3) **Welding procedure qualification tests for repair of cast steel propeller** (2021)

(A) *General*

- (a) For the welding procedure approval the welding procedure qualification tests are to be carried out with satisfactory results. The qualification tests are to be carried out with the same welding process, filler metal, preheating and stress-relieving treatment as those intended applied by the actual repair work. Welding procedure specification is to refer to the test results achieved during welding procedure qualification testing.
- (b) Welding procedures qualified at a manufacturer are valid for welding in workshops under the same technical and quality management.

(B) *Test piece and welding of sample*

- (a) The test assembly, consisting of cast samples, is to be of a size sufficient to ensure a reasonable heat distribution and according to **Fig 2.1.15** of the Guidance with the minimum dimensions.



- Note) 1 : Joint preparation and fit-up as detailed in the preliminary Welding Procedure Specification  
a : minimum value 150mm  
b : minimum value 350mm  
t : material thickness

**Fig 2.1.15 Test piece for welding repair procedure**

- (b) Preparation and welding of test pieces are to be carried out in accordance with the general condition of repair welding work which it represents.
  - (c) Welding of the test assemblies and testing of test specimens are to be witnessed by the Surveyor.
- (C) *Examinations and tests*
- (a) Test assembly is are to be examined non-destructively and destructively in accordance with **Table 2.1.18** and **Fig 2.1.16** of the Guidance.

Table 2.1.18 Type of tests and extent of testing

Type of test	Extent of testing
Visual testing	100% as per article (b)
Liquid penetrant testing <sup>(1)</sup>	100% as per article (b)
Transverse tensile test	Two specimens as per article (c)
Bend test <sup>(2)</sup>	Two root and two face specimens as per article (d)
Macro examination	Three specimens as per article (e)
Impact test	Two sets of three specimens as per article (f)
Hardness test	As per article (g)

Notes:

1. Magnetic particle testing may be used in lieu of liquid penetrant testing for martensitic stainless steels.
2. For  $t \geq 12\text{mm}$ , the face and root bend may be substituted by 4 side bend test specimens.

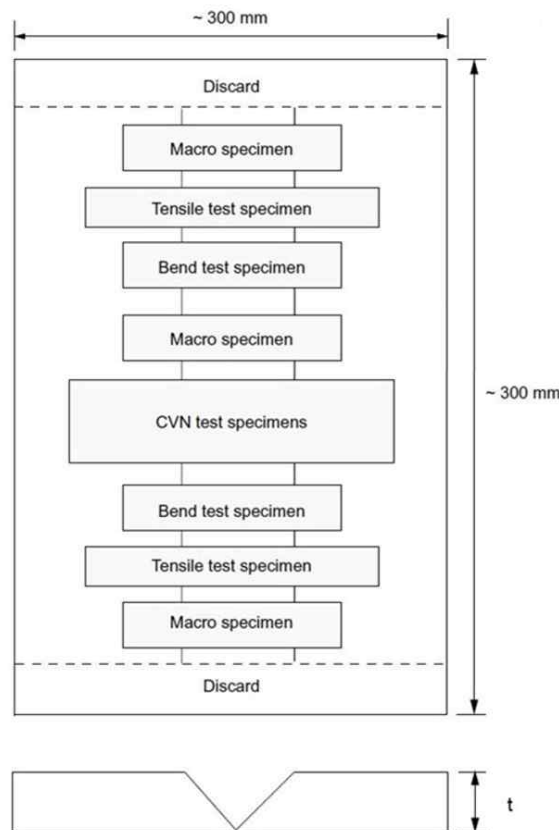


Fig 2.1.16 Weld test assembly

- (b) Non-destructive testing
  - (i) Test assembly is to be examined by visual and liquid penetrant testing, or magnetic particle testing if applicable, prior to the cutting of test specimen. In case, that any post-weld heat treatment is required or specified, non-destructive testing is to be performed after heat treatment.
  - (ii) No cracks are permitted. Imperfections detected by liquid penetrant testing, or magnetic particle testing if applicable, are to be assessed in accordance with **Annex 2-6**.
- (c) Tensile test
  - (i) Two flat transverse tensile test specimens shall be prepared. Testing procedures shall be in accordance with **Pt2, Ch1, 203**, of the Rules. Alternatively tensile test specimens according to recognized standards acceptable to the Society may be used.
  - (ii) The tensile strength shall meet the specified minimum value of the base material. The location of fracture is to be reported, i.e. weld metal, HAZ or base material.
- (d) Bend test
  - (i) Transverse bend tests for butt joints are to be in accordance with **Pt2, Ch2, 204**, of the Rules, or, according to a recognized standard. The mandrel diameter shall be 4 x thickness except for austenitic steels, in which case the mandrel diameter shall be 3 x thickness.
  - (ii) The bending angle is to be 180°. After testing, the test specimens are not to reveal any open defects in any direction greater than 3 mm. Defects appearing at the corners of a test specimen during testing are to be investigated case by case.
  - (iii) Two root and two face bend specimens are to be tested. For thickness 12 mm and over, four side bend specimens may alternatively be tested.
- (e) Macro-examination

Two macro-sections shall be prepared and etched on one side to clearly reveal the weld metal, the fusion line, and the heat affected zone. Cracks and lack of fusion are not permitted. Imperfections such as slag inclusions, and pores greater than 3 mm are not permitted.
- (f) Impact test
  - (i) Impact test is required, where the base material is impact tested. Charpy V-notch test specimens shall be in accordance with **Pt2, Ch1, 202. 3**, of the Rules. Two sets shall be taken, one set with the notch positioned in the center of the weld and one set with the notch positioned in the HAZ (i.e. the mid-point of the notch shall be at 1 mm to 2 mm from the fusion line), respectively.
  - (ii) The test temperature, and impact energy shall comply with the requirement specified for the base material.
- (e) Hardness test

The macro-section representing the start of welding shall be used for HV 10 hardness testing. Indentations shall traverse 2 mm below the surface. At least three individual indentations are to be made in the weld metal, the HAZ(both sides) and in the base metal(both sides). The values are to be reported for information.
- (f) Re-testing

If the test piece fails to comply with any of the requirements of this Appendix, reference is made to re-test procedures given in **Pt2, Ch2, 406. 1**, of the Rules.
- (D) *Test record*
  - (a) Welding conditions for test assemblies and test results are to be recorded in welding procedure qualification. Forms of welding procedure qualification records can be accordance with an accepted form at the discretion of the Society.
  - (b) A statement of the results of assessing each test piece, including repeat tests, is to be made for each welding procedure qualification records. The relevant items listed for the WPS are to be included.
  - (c) The welding procedure qualification record is to be signed by the Surveyor witnessing the test and is to include the Society's identification.
- (E) *Range of approval*
  - (a) General
    - (i) All the conditions of validity stated below are to be met independently of each other. Changes outside of the ranges specified are to require a new welding procedure test.

- (ii) A qualification of a WPS obtained by a manufacturer is valid for welding in work-shops or sites under the same technical and quality control of that manufacturer.
- (b) Base metal  
Range of approval for steel cast propeller is limited to steel grade tested.
- (c) Thickness  
The qualification of a WPS carried out on a weld assembly of thickness  $t$  is valid for the thickness range given in **Table 2.1.19** of the Guidance.

**Table 2.1.19 Range of qualification for thickness**

Thickness of the test piece, $t$ (mm)	Range of approval(mm)
$15 < t \leq 30$	$3 \leq T \leq 2t$
$30 < t$	$0.5t \leq T \leq 2t$ or 200 mm(whichever is the greater)

- (d) Welding position  
Approval for a test made in any position is restricted to that position.
- (e) Welding process  
The approval is only valid for the welding process used in the welding procedure test. Single run is not qualified by multi-run butt weld test.
- (f) Filler metal  
The approval is only valid for the filler metal used in the welding procedure test.
- (g) Heat input  
The upper limit of heat input approved is 15 % greater than that used in welding the test piece. The lower limit of heat input approved is 15 % lower than that used in welding the test piece.
- (h) Preheating and interpass temperature  
The minimum preheating temperature is not to be less than that used in the qualification test. The maximum interpass temperature is not to be higher than that used in the qualification test.
- (i) Post-weld heat treatment  
The heat treatment used in the qualification test is to be specified in pWPS. Holding time may be adjusted as a function of thickness.

## 506. Grey iron casting

### 1. Application

"deemed necessary by the Society" referred in **506. 1 (2)** of the Rules means where it is applicable for the other materials than the specified ones in **Pt 2** of the Rules. **【See Rule】**

### 2. Test samples

The chill test specified in **506. 6 (7), (d)** of the Rules is to comply with *ASTM A367-60*(Standard test methods of chill tests of cast iron). **【See Rule】**

## 507. Spheroidal or nodular graphite iron castings

### 1. Application

- (1) In application to **507. 1 (2)** of the Rules, the term "additional requirements" means the acceptance in accordance with **Pt 1, Ch 1, 105.** of the Rules. **【See Rule】**
- (2) "deemed necessary by the Society" referred in **507. 1 (3)** of the Rules means where it is applicable for the other materials than the specified ones in **Pt 2** of the Rules. **【See Rule】**

## Section 6 Steel Forgings

### 601. Steel Forgings

#### 1. Manufacturing process

(1) The application to the requirements of **601. 3** (5), (a) of the Rules is to be in accordance with the following : **【See Rule】**

For crankshafts, where grain flow is required in the most favourable direction having regard to the mode of stressing in service, the proposed method of manufacture may require special approval by the Society. In such cases, tests may be required to demonstrate that a satisfactory structure and grain flow are obtained.

(2) The application to the requirements of **601. 3** (6) of the Rules is to be in accordance with the following : **【See Rule】**

These requirements apply to where gas workings are being carried out on the parts subjected to high stress such as mass removal of crankshaft. The data related to the processes (including preheating) and change of material due to working are to be submitted approval of the Society.

#### 2. Heat treatment

The application to **601. 4** (1) of the Rules is to be in accordance with the following :

(1) The application to **601. 4** (1) of the Rules is to be in accordance with the following :

Overall length of the product is not afforded to be heat treated simultaneously, it is requested that an approval of the surveyor be obtained beforehand. In this case, one set of test specimens is to be taken from each end of the product. Degree of heterogeneity in micro structure at the boundary zone caused by such a heat treatment is to be examined by the method deemed appropriate by the Society and ultrasonic test. **【See Rule】**

(2) "For the purposes of this approval" referred in **601. 4** (7) of the Rules includes where surface harden forgings method is not normal or manufacturers don't have sufficient knowledge and experience, etc. **【See Rule】**

#### 3. Mechanical properties

In application to **601. 6** Note (4) of **Table 2.1.89** of the Rules, the kinds and average absorbed energy for alloys steel forgings intended to be used for important parts of machinery which the impact test may be required are to comply with the requirements of **Table 2.1.20** of the Guidance. **【See Rule】**

**Table 2.1.20 Kinds and Average Absorbed Energy for Alloys Steel Forgings**

Grades	Alloys Steel forging applied	Charpy V notch Impact test	
		Average absorbed energy(J)	
		<i>L</i>	<i>T</i>
<i>RSF 600AM</i>	- Crankshaft - Forgings for gears	41 min.	24 min.
<i>RSF 700AM</i>		32 min.	22 min.
<i>RSF 800AM</i>		32 min.	20 min.
<i>RSF1000AM</i>		25 min.	16 min.
<i>RSF1100AM</i>		21 min.	13 min.
(Note) Impact tests are to be carried out at ambient temperature (23±5 ° c). (2023)			



#### 4. Selection of test specimen

Selection of the test specimens for forgings subjected to surface hardening, except for carburizing, specified in **601. 7** (9) of the Rules and hardness test are to comply with the following requirements. **[See Rule]**

(1) **Induction hardened or nitrided gears**

(A) *Tensile and impact test specimens*

The test specimens are to be taken from the product after the final heat treatment and before the surface hardening in accordance with the requirements specified in **601. 7** (3), (b) through (e) of the Rules

(B) *Depth of the hardened layer*

(a) In case of induction hardening

The depth of the hardened layer of the product is to be measured when the gear is produced for the first time, and tests thereafter may be dispensed with.

(b) In case of nitridation

(i) Selection of test samples

Test samples are to be made of the same material as the product having been processed under the same conditions.

(ii) Size of test samples

The size of the test samples may be optional.

(iii) Heat treatments of test samples

The test samples are to be heat treated and nitrided simultaneously together with the product.

(iv) Measurements of depth of hardened layer

The depth of hardened layer is to be measured every lot of same nitridation.

(2) The hardness tests of the surface hardened gears are to be dealt with as follows :

(A) The requirements for the measurement of hardness after surface hardening processes have been required related to the Shafting and Power Transmission Systems in **Pt 5, Ch 3** of the Rules, and the measured hardness value is to be approved by the Society in relation of the approval of the manufacturing processes.

(B) In case where the measurements of hardness for every forged products are difficult owing to their sizes and shapes, the hardness may be measured at appropriate locations considered to be representative in respect to the value of hardness resulted from the approval tests for the manufacturing processes referred to in (A) above.

#### 5. Surface inspection

The requirements specified in **601. 8** of the Rules are to be dealt with as follows : **[See Rule]**

(1) The surface inspection of steel forgings is to comply with the **Annex 2-5, 2**.

#### 6. Non-destructive inspection

(1) Non-destructive inspection of steel forgings specified in **601. 10** (1) and (2) of the Rules are to be dealt with as follows: **[See Rule]**

(A) The non-destructive inspection of steel forgings are to comply with the **Annex 2-5, 2** and **3**.

(B) Ultrasonic examination is to be carried out after the forgings have been machined to a condition suitable for this type of examination and after the final heat treatment. Both radial and axial scanning are to be carried out where appropriate for the shape and the dimensions of the forgings being examined. (2023)

(C) Unless otherwise agreed, examinations are to be carried out by the manufacturer, although Surveyors may request to be present in order to verify that the examination is being carried out in accordance with the agreed procedure. (2023)

(D) If the forging is supplied in the 'as forged' condition for machining at a separate works, the manufacturer is to ensure that a suitable ultrasonic examination is carried out to verify the internal quality of the forging. (2023)

(E) Where advanced ultrasonic testing methods are applied, e.g. PAUT or TOFD, reference is made to **Annex 2-12**, for general approach in adopting and application of these advanced

methods. In such cases, acceptance levels regarding accept/reject criteria may be as per the applicable section in **Annex 2-5. (2023)**

- (2) "other non-destructive inspections considered adequate by the Society" referred in **601. 10 (4)** of the Rules means the non-destructive considering materials, shapes and stress conditions, etc. **【See Rule】**
- (3) "deemed necessary by the Society" referred in **601. 10 (5)** of the Rules means the steel forging is difficult to detect a defect by visual inspection. **【See Rule】**
- (4) "the non-destructive inspections considered adequate by the Society" referred in **601. 10 (6)** of the Rules means the non-destructive considering the welded part's materials, shapes and stress conditions, etc. **【See Rule】**

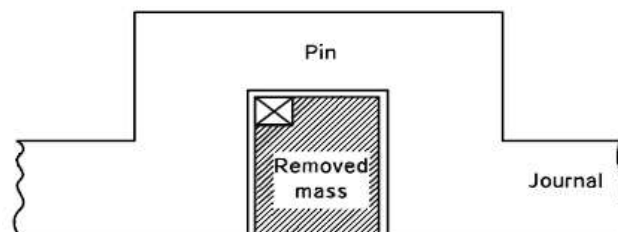
## 7. Repair of defects

The application to **601. 11 (4)** of the Rules is to be accordance with the following: **【See Rule】**

- (1) Repair by welding in order of correct shapes for the portions not subjected to high stress may be accepted.

## 8. Additional requirements for crank shafts

- (1) In **601. 15 (1)** of the Rules, where the heat treatments of the crank throws of solid crank shafts are carried out without mass removal, one set of test specimens are to be taken from the removed mass of the central crank throw at the part neighboring the pin, as shown in **Fig 2.1.17** of the Guidance after the heat treatment. **【See Rule】**



**Fig 2.1.17 Location of Test Specimens**

- (2) In relation to the tests for semibuilt-up crank throws specified in **601. 15 (2)** of the Rules, following requirements are with. to be complied **【See Rule】**
  - (A) Test specimens are to be taken, in general, one set from each arm in the longitudinal direction.
  - (B) In case where either the process of manufacturing those approved are intended to be changed or cranks larger than ever approved are intended to be manufactured, the tests instructed by the Society are to be newly carried out.

## 603. Steel forgings for chains

### 1. Application

- (1) In application to **603. 1 (2)** of the Rules, Steel forgings for offshore mooring chain are to comply with **Annex 2-9, 3** of this guidance. **【See Rule】**
- (2) In application to **603. 1 (4)** of the Rules, the term "considered by the Society" means the acceptance in accordance with **Pt 1, Ch 1, 105.** of the Rules. **【See Rule】**

---

## Section 7 Copper and Copper Alloys

### 702. Copper alloy castings

#### 1. Application

"special consideration of the Society" referred in **702. 1** (1) of the Rules includes the possible normal operation throughout the repair of propellers damaged in service. **【See Rule】**

#### 2. Manufacturing process

In application to **702. 3** (3) of the Rules, the stress relieving temperatures and holding times are to comply with the **Annex 2-6**. **【See Rule】**

#### 3. Mechanical properties

(1) In application to **702. 5** of the Rules, the term "deemed appropriate by the Society" means the acceptance in accordance with **Pt 1, Ch 1, 105.** of the Rules. **【See Rule】**

(2) The wording " specially required considering the design by the Society" in **Table 2.1.102**, Note 1 of **702. 5** of the Rules means in case where the requirements specified in **Pt 5, Ch 3, 305. 2** (1) (g) of the Guidance are applied. **【See Rule】**

#### 4. Surface and dimension inspection

In application to **702. 7** (2) of the Rules, procedure for straightening of propeller casting is to comply with **Annex 2-6**. **【See Rule】**

#### 5. Non-destructive inspection

(1) The liquid penetrant test of steel propeller casting specified in **702. 9** (1) of the Rules is to comply with **Annex 2-6**. **【See Rule】**

(2) The division of severity zones of steel propeller casting specified in **702. 9** (2) is to comply with the **Fig 1** and **2** of **Annex 2-6**. **【See Rule】**

#### 6. Repair of Defects

In application to **702. 10** (5) of the Rules, repair welding of propeller castings is to comply with **Annex 2-6**. **【See Rule】**

## Section 8 Aluminium Alloys

### 801. Aluminium alloys

#### 1. Mechanical properties

(1) In connection with the **801. 1 (2)** of the Rule, aluminium alloys exceeding the maximum value of plate thickness or size specified in **Table 2.1.106** and **Table 2.1.107** are comply with the requirements given in **Tables 2.1.21** of the Guidance. **[See Rule]**

**Table 2.1.21 Mechanical Properties for Alluminium Alloys<sup>(1)</sup>**

Product	Grades	Temper condition <sup>(2)</sup>	Thickness, <i>t</i> (mm)	Tensile test		
				Yield strength (N/mm <sup>2</sup> )	Tensile strength (N/mm <sup>2</sup> )	Elongation(%) ( $L = 5.65\sqrt{A}$ )
Rolled	5083P	O	50( $t \leq 80$ )	115~200	270~345	14 min.
			80( $t \leq 100$ )	110 min.	260 min.	12 min.
		H321	50( $t \leq 80$ )	200~295	285~385	11 min.
Extruded Shapes	5083S	O	50( $t \leq 130$ )	110 min.	275~355	10 min. <sup>(3)</sup>

NOTES :

(1) Aluminium alloy may be subject to any other standards in lieu of the requirements given in this Table where they are approved by the Society.

(2) Symbols used in temper condition are as follows :  
O : Annealing  
H321 : Stabilizing treatment after work hardened  
And definitions of the symbols used in temper condition are to comply with the requirements in **Table 2.1.24** of the Guidance.

(3) The values are applicable for longitudinal and transverse tensile test specimens as well.

(2) In connection with the **801. 5 (2)** of the Rule, for verification of proper fusion of press welds for closed profiles, the Manufacturer has to demonstrate by drift expansion tests of closed as follows; **[See Rule]**

- (a) Batches of five profiles or less shall be sampled one profile. Each profile sampled will have two samples cut from the front and back end of the production profile. The test specimens are to be cut with the ends perpendicular to the axis of the profile.
- (b) Profiles with lengths exceeding 6 m shall be sampled every profile in the start of the production. The number of tests may be reduced to every fifth profile if the results from the first 3-5 profiles are found acceptable.
- (c) The size of the specimen and testing procedure are to be in accordance with the requirements in **401. 5 (3)** of the Rule.
- (d) The sample is considered to be unacceptable if the sample fails with a clean split along the weld line which confirms lack of fusion.

#### 2. Heat treatment

In application to **801. 4**, Note (2) of **Table 2.1.105** and **Table 2.1.106** of the Rules, definitions of the symbols used in temper condition are to comply with the requirements in **Table 2.1.22** of the Guidance. **[See Rule]**

Table 2.1.22 Definition of the symbols used in temper condition

Symbols	Definition <sup>(1)</sup>	Application <sup>(1)</sup>
<i>O</i>	Annealing	Applies to wrought alloys which are annealed to obtain the softest temper
<i>H111</i> , <i>H112</i> and <i>H116</i>	Work hardened only.	Applies to products which are strain-hardened to achieve the strength desired without additional thermal treatment
<i>H321</i>	Stabilizing treatment after work hardened <sup>(2)</sup>	Applies to alloys that are strain-hardened and whose mechanical properties are stabilized by a low temperature thermal treatment that results in slightly lowered tensile strength and improved ductility.
<i>T5</i>	Artificial age hardening only <sup>(3)</sup>	Applies to alloys which are not cold worked after cooling from an elevated temperature shaping process
<i>T6</i>	Artificial age hardening treatment <sup>(3)</sup> after solution treatment <sup>(4)</sup>	Applies to alloys which are not cold worked after solution heat-treatment
<p>Note</p> <p>(1) Refer to <i>KS D0049</i>(Ferrous products-Heat treatments-Vocabulary) and <i>KS D0004</i>(Temper Designation for Aluminium and Aluminium Alloys)</p> <p>(2) Stabilising is the relief of residual internal stresses by heating to a predetermined temperature, usually in the region of 250°C, then cooling slowly.</p> <p>(3) Age hardening is the increasing the hardness of an alloy by a relatively low-temperature heat treatment that causes precipitation of components or phases of the alloy from the supersaturated solid solution.</p> <p>(4) Solution treatment is the heating and holding an alloy at a temperature at which one (or more) constituent enters into solid solution, then cooling the alloy rapidly to prevent the constituent from precipitating</p>		

### 3. Corrosion testing

In application to **801. 9** (2) (a), (c) of the Rules, the term "equivalent standards agreed by the Society" means the acceptance in accordance with **Pt 1, Ch 1, 105.** of the Rules. **【See Rule】**

### 4. Surface inspection and dimensional tolerance

- (1) In application to **801. 10** (2) of the Rules, the term "deemed appropriate by the Society" means the acceptance in accordance with **Pt 1, Ch 1, 105.** of the Rules. **【See Rule】**
- (2) "Dimension tolerance except those specified in previous (2)" given in requirements of **801. 10** (3) of the Rules may comply with a recognized national or international standard accepted by the Society. **【See Rule】**

## 802. Aluminium/steel transition joints (2023)

### 1. Quality and repair of defects

Ultrasonic test generally complies with *KS D 0234*.(Testing methods for clad steel) or national/international Standards recognised by the Society. **【See Rule】**

2. In application to **802. 2** (4) and **7** of the Rules, the term "the discretion of the Society" means the acceptance in accordance with **Pt 1, Ch 1, 105.** of the Rules. **【See Rule】** ↓

## CHAPTER 2 WELDING

### Section 1 General

#### 102. Matters to be approved

"deemed appropriate by the Society" referred in **102. 2** of the Rules means where it is applicable for the other materials and welding than the specified ones in **Pt 2** of the Rules. **[See Rule]**

#### 103. Special weldings

Production weld test for tanks of ships carrying liquefied gases in bulk, and tank circumference hull construction units.

##### 1. Application

When welding is made for independent tanks of ships carrying liquefied gases in bulk, the production weld tests are to be carried out for each position of welding in accordance with the following requirements, in addition to the welding procedure qualification tests specified in **Ch 2, Sec. 4** of the Rules.

- (1) For Type A independent tanks, the production weld test is to be carried out on at least one test sample for every 50 m of welding length of butt joints of principal structural members.  
However, consideration may be given for reduction of the number of test sample or omission of the production weld test by taking into account the past records and the actual state of quality control system of the manufacturer.
- (2) For Type B independent type tanks, the production weld tests are to be carried out on at least one test sample for every 50 m of welding length of butt joints of principal structural members.  
However, the number of test sample may be reduced to one test sample for every 100 m of welding length by taking into account the past records and the actual state of quality control system of the manufacturer. In this case, however, at least one or more test specimens are to be selected for one tank.
- (3) For Type C independent type tanks, the production weld tests are to be carried out on at least one test sample for every 30 m of welding length of butt joints of principal structural members.  
However, the number of test sample may be reduced to one test sample for every 50 m of welding length by taking into account the past records and the actual state of quality control system of the manufacturer.

Remark : The definitions of type A, B and C independent tank comply with the requirements in the **Pt 7, Ch 5, 401.** of the Rules.

##### 2. Test procedure

- (1) The production weld tests are to be carried out for every welding length specified in the above **1.** for welded joints made under the same welding procedure, position of welding and welding conditions.
- (2) Test samples are, in principle, to be located on the same line as the welded joints of the body and to be welded at the same time of welding of the body.

##### 3. Kind of test

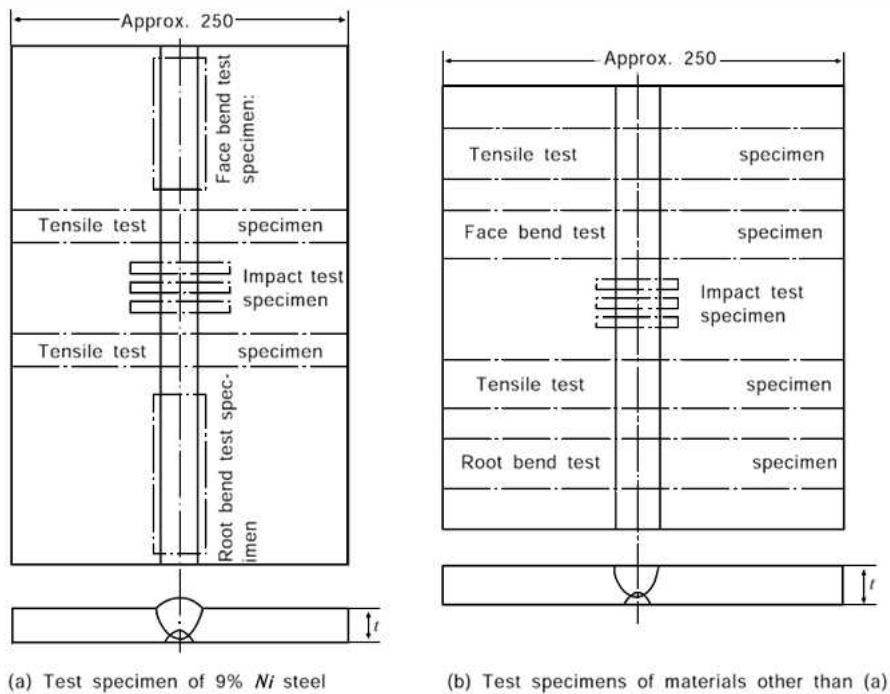
Kinds of the test are to be as given in **Table 2.2.1** of the Guidance.

**Table 2.2.1** Kind of Test

Material	Kind of Test
9 % Ni steel	Tensile test, bend test and impact test
Stainless steel	Tensile test and bend test
Aluminium alloys	Tensile test and bend test
Steel for low temperature service (excluding 9 % Ni steel)	Tensile test, bend test and impact test

#### 4. Test assemblies

The shape and size of test assemblies are to be as shown in **Fig 2.2.1** of the Guidance. In cases of Type A and Type B independent tanks, tensile test may not be required.



**Fig 2.2.1 Test Specimens for Production Weld Test (Units : mm, thickness  $t$ )**

#### 5. Test specimens

- (1) The shape and size of tensile test specimens are to be of the *R2A* test specimen specified in **Table 2.2.1** of the Rules.
- (2) The shape and size of bend test specimens are to be of the *RB1* or *RB2* test specimens specified in **Table 2.2.2** of the Rules. For test specimens with a thickness exceeding 19 mm, side bend test specimens are to be substituted for face bend and root bend test specimens.
- (3) Impact test specimens are to be the charpy V-notch test specimen specified in **Table 2.1.3** of the Rules. In the impact test, one set of test specimens comprising three pieces are to be taken from every test assembly. The test specimens are to be taken alternately from the position "a" and from a position among "b" through "e" where the lowest value is recorded in the welding procedure qualification test, shows in **Fig 2.2.8** of the Rules. This means that one set of three test specimens are taken from a test assembly at the position "a", hence other set of three test specimens are taken in the subsequent test assembly from the position among "b" through "e" where the lowest value is recorded, and this procedure is repeated. No impact test specimens is required in cases of stainless steel and aluminium alloy.

#### 6. Tensile test

- (1) The tensile strength of 9% Ni steels is to be 630 N/mm<sup>2</sup> or more.
- (2) The tensile strength of stainless steels, aluminium alloys and steels for low temperature service (excluding 9% Ni steels) is to be more than the specified value of the base metal.

#### 7. Bend test

- (1) The bend test specimen is to be bent up to an angle of 180° by a test jig with an inner radius of double (three and a third times for aluminium alloys) the thickness of the test specimen.
- (2) The results of the bend test are to be as free from cracks exceeding 3 mm in length in any direction on the outer bent surface and from other significant defects.

#### 8. Impact test

The specified values for the impact test are as given in **Table 2.2.8** of the Rules.

### Section 3 Welding Works and Inspection

#### 303. Application of welding consumables

1. Hydrogen cracking test specified in **303. (4)** of the Rules is to comply with *KS B ISO 17642-2* or equivalent. **【See Rule】**
2. In order to use 4Y46 and 5Y46 specified in **Table 2.2.3** Notes (6) of **303.** of the Rules, the manufacturer of the welding consumables is to be guaranteed that it can be used for EH47-H, and the welding procedure qualification test of the shipyard/manufacturer is to be carried out with satisfactory results in accordance with **Pt 2, Ch 2, Sec 4** of the Rules. (2021) **【See Rule】**

#### 304. Preparation for Welding

##### 1. Tack welding

- (1) The application to **304. 2. (3)** of the Rules is to be in accordance with the followings: **【See Rule】**
  - (A) The bead length of tack welds is to comply with **Table 2.2.2** of the Guidance.

**Table 2.2.2** Bead length of tack welds

Steel grade	Kinds	Required Bead length	Remark
Higher strength- low alloy steel	$Ceq > 0.36\%$	$\geq 50$ mm	including TMCP
Steel casting	$Ceq \leq 0.36\%$	$\geq 30$ mm	
grade E mild steel		$\geq 30$ mm	

- (B) The pitch of tack welds should generally be approximately 400 mm or shorter.

#### 305. Welding sequence and direction of welding

1. "The special approval of the Society" specified in **305. 3** of the Rules means the fillet weld to satisfy the following. **【See Rule】**
  - (1) The welding procedure qualification tests specified in **Sec. 4** of the Rules are accepted as successful.
  - (2) The welding consumables are to be those for welding with direction of vertical-downward approved by the Society.
  - (3) The joints of steels which welding with direction of vertical- downward is restricted, in general, is to comply with **Table 2.2.3-1** of the Guidance.

**Table 2.2.3-1** Joints of Steels which Welding with Direction of Vertical Downward is restricted

Grade of steels	Welded joints
Rolled steels for hull	Joints of any E grade to any E grade(E, EH32 and EH36)
Rolled steels for low temperature services	Joints of any steels for low temperature service to any steels for low temperature service, Joints of any steels for low temperature service to any grade of steels
High Strength Steels for Welded Structures	Joints of any high strength steels to any high strength steels, Joints of any high strength steels to any grade of steels
Stainless clad steel plates	Joints of any stainless clad steel plates to any stainless clad steel plates, Joints of any stainless clad steel plates to any grade of steels
Rolled stainless steels	Joints of any rolled stainless steels to any rolled stainless steels, Joints of any rolled stainless steels to any grade of steels



- (4) The zones where welding with direction of vertical- downward is restricted to hull structure, in general, is to comply with **Table 2.2.3-2** of the Guidance.
2. Notwithstanding the provisions of 1 (3) and (4), the other plans presented by shipbuilder or manufacturer may be accepted provided that the quality control system of shipbuilder and the importance of the welds are considered and deemed appropriate by the Society.

**Table 2.2.3-2 Zones where Welding with Direction of Vertical Downward is restricted**

Divisions	Locations and members
Fillet welded joints of primary strength member	<ul style="list-style-type: none"> <li>- The welds of BHD(See Fig 2.2.2, (a) of the Guidance)</li> <li>- Cross hatching areas of Fig 2.2.2, (c) of the Guidance within connection areas of solid floor and girder</li> <li>- Connection areas of primary strength member and bottom shell, side shell, upper deck and double bottom tank top</li> </ul>
Areas where water, oil and air tightness are required	<ul style="list-style-type: none"> <li>- Boundary line where water, oil and air tightness are required</li> <li>- The area whose distance from the end of tight collar plate shall be at least 50mm (See Fig 2.2.2, (d) of the Guidance)</li> </ul>
Areas where structural continuity is required or where high concentrated stress is expected	<ul style="list-style-type: none"> <li>- The end of heavy bracket (See Fig 2.2.2, (b) of the Guidance)</li> <li>- Longitudinal strength members (See Fig 2.2.2, (e) of the Guidance)</li> </ul>
Areas where high concentrated loads is expected	<ul style="list-style-type: none"> <li>- The lower part of crane post</li> <li>- The lower part of crane pedestal</li> </ul>
Specified areas	<ul style="list-style-type: none"> <li>- The lower part of main engine : Connection areas of main engine girder and floor</li> <li>- Hatch cover : Connection area of side plate and end plate</li> <li>- Hatch coaming : Connection areas of main plate and top plate, Connection areas of main plate main plate</li> <li>- Shaft bed</li> <li>- Rudder horn : Connection areas of casting steels and normal strength steels</li> <li>- Rudder : Connection areas of rudder main pieces and rudder stocks, Connection areas of casting forging steels and normal strength steels</li> <li>- Bracket toe</li> </ul>
<p>(Note) Harmful defects such as cracks may, if necessary, be inspected by magnetic particle inspection or liquid penetrant inspection and, where the condition of the quality is serious, the welding work is to discontinue until measures for importance are planned.</p>	

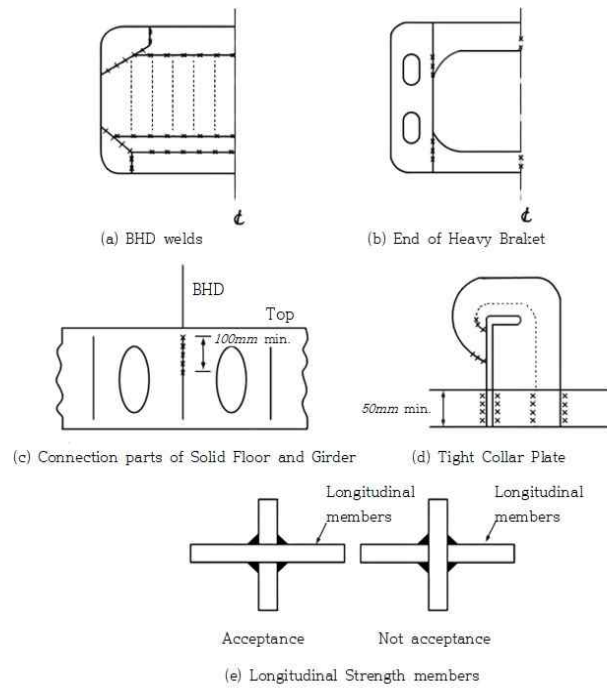


Fig 2.2.2 Zones where Welding with Direction of Vertical Downward is restricted (Cross hatching zone of Fig )

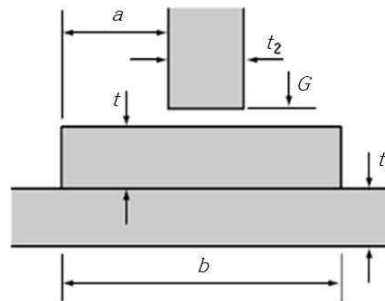
### 306. Main welding

- In application of **306. 2** of the Rules, minimum preheating temperature for welding hull steels at low temperature is to comply with **Table 2.2.4** of the Guidance. **[See Rule]**

**Table 2.2.4 Preheating for Welding Hull Steels at Low Temperature (2024)**

Grades	Standard	
	Base metal temperature needed preheating	Minimum preheating temperature
Normal strength steels (A, B, D, E)	below -5°C	20°C or over <sup>(1)</sup>
Higher strength steels (AH32, DH32, EH32, AH36, DH36, EH36)	below 0°C	
Note :		
(1) This level of preheat is to be applied unless the approved welding procedure specifies a higher level		

- "The welding inserting a liner of suitable size" in **306. 8** of the Rules complies with the **Fig 2.2.3** of the Guidance. **[See Rule]**



(Notes)

1. Welding size is to comply with the following:

$$t_2 \leq t \leq t_1$$

$$G \leq 2mm$$

$$a = 5mm + \text{fillet leg length}$$

2. Not to be used in cargo area or areas of tensile stress perpendicular liner

Fig 2.2.3 Fillet Welding inserting a Liner

3. In application to **306. 9** of the Rules, the term "special approval of the Society" means the acceptance in accordance with **Pt 1, Ch 1, 105.** of the Rules. **【See Rule】**

### 309. Quality of welds

In **309. 3** of the Rules, the application to the non-destructive inspection specified elsewhere is to comply with **Annex 2-7.** **【See Rule】**

## Section 4 Welding Procedure Qualification Tests

### 403. Welding procedure qualification tests(WPQT)

#### 1. Welding procedure qualification tests for duplex stainless steels

In application to **403. 6** of the Rules, the welding procedure qualification tests for duplex stainless steels are to comply with the followings: **[See Rule]**

##### (1) General

- (a) The requirements for approval test items, test methods and acceptance criteria, other than this requirement, are to be in accordance with **Pt 2, Ch 2, Sec 4** of the Rules.
- (b) Approval range is to be in accordance with **Pt 2, Ch 2, 407.** of the Rule. The lower limit of heat input approved is 15 % lower than that used in welding the test piece. And the upper limit of heat input approved is 15 % greater than that used in welding the test piece.

##### (2) Impact test

Requirements in **Pt 2, Ch 2, Sec 4.** of the Rule are to be followed for impact test. 27 J at -20 °C is to be satisfied. The number of test specimens and the position of notch for the test specimen are as specified in **Fig 2.2.7** of the Rules. The value of average absorbed energy(J) at -20 °C is to be satisfied with 27 J for center of weld and is to be more than the specified value of the base metal for fusion line and HAZ. (2017)

##### (3) Corrosion resistance test

- (a) The duplex with equal or higher corrosion resistance of Type 25Cr shall be corrosion tested in accordance with ASTM G48 Method A. But under non corrosive area, welding between duplex stainless steels and other stainless, carbon steels may not need to be tested for corrosion resistance.
- (b) The test temperature shall be 40 °C and the exposure time shall be minimum 24h.
- (c) The test specimens shall have a dimension of full wall thickness by 25 mm along the weld and 50mm across the weld. The test shall expose the face and root surface and a cross section surface including the weld zone in full wall thickness.
- (e) Pickling may be performed for 5 min at 60°C in a solution of 20% HNO<sub>3</sub> + 5% HF.
- (f) Acceptance Criteria
  - (i) There shall be no pitting at 20 X magnification.
  - (ii) The weight loss shall not exceed 4.0 g/m<sup>2</sup>.

##### (4) Micro structure test

- (a) The test specimen shall be examined and comprise a cross section of the weld metal, HAZ and the base metal.
- (b) The micro structure shall be suitably etched and examined at 400 ~ 500 X magnification in total 6 points, each 2 points for weld metal root, last bead of the weld cap and HAZ. The micro structure shall have grain boundary with no continuous precipitations and the inter-metallic phases, nitrides and carbides shall not in total exceed 0.5%. (2017) (2022)
- (c) The ferrite content in total 6 points, each 2 points for weld metal root, last bead of the weld cap and HAZ, shall be determined in accordance with *ASTM E 562* and shall be in the range of 30% to 70%. (2017)

##### (5) Tee joints with full penetration (2017)

- (a) The requirements stated hereunder apply to the Tee joints with full penetration welded by manual, semi-automatic or automatic welding in any welding position.
- (b) Kinds and number of specimens for test : Kinds of test and number of test specimens are to be given in **Table 2.2.5** of the Guidance. Additional test may be required where found necessary by the Society.

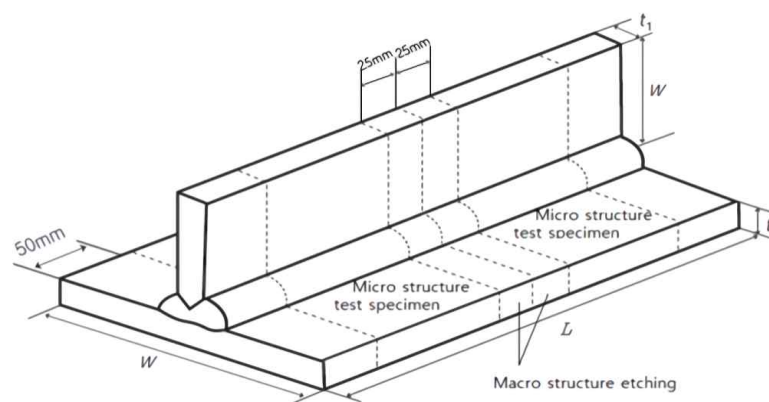
Table 2.2.5 Kinds of Test for Tee joints with full penetration

Grades and material symbols of test specimens		Kinds and number of specimens for test			
		Visual insp.	Micro-structure insp.	Macro-structure insp.	Non-destructive insp. <sup>(1)</sup>
Duplex stainless steels	RSTS31803, RSTS32750	Welding positions of whole length	1 (6 points) <sup>(2)</sup>	2	Welding positions of whole length

NOTES:  
 (1) Internal inspections by radiographic examination or ultrasonic examination and surface inspections by magnetic particle examination or liquid penetrant examination are to be carried out.  
 (2) The points are to be evenly selected in first and second weld side.

(c) Test assemblies

- (i) Test assembly is to be prepared with the same or equivalent material used in the actual work.
- (ii) Dimensions and type of test assembly are to be as indicated Fig 2.2.4 of the Guidance.
- (iii) Test assembly is to be welded in the same welding positions as the actual work.



NOTES :

1. The length of test specimen is as follows :
  - (1) Manual and semi-automatic welding : Width  $W=3 \times t$ , min. 150 mm, Length  $L=6 \times t$ , min. 350 mm
  - (2) Automatic welding : Width  $W=3 \times t$ , min. 150 mm, Length  $L=\text{min. } 1000 \text{ mm}$
2. Thickness of webs and flanges of the test assembly,  $t_1$  and  $t_2$  are to be of ordinary thicknesses used in the actual work.
3. Tack weld may be applied to the test assembly.
4. For manual and semi-automatic welding, a stop/restart is to be included in the test length and its position is to be clearly marked for subsequent examination. For multi-run welding, two(2) macro-structure specimens are to be prepared since a stop/restart area has a long field.

Fig 2.2.4 Test assembly for Tee joint with full penetration (unit : mm)

- (d) Visual inspection : Welding surface is to be regular and uniform surface and is to be free from injurious defects, such as cracks, undercuts, overlaps, etc.
- (e) Micro structure test : Micro structure test is to be given in (4)
- (f) Macro-structure inspection
  - (i) The test specimens are to be prepared and etched on one side to clearly reveal the weld metal, fusion line, root penetration and the heat affected zone. Macro examination is to include about 10 mm unaffected base metal.
  - (ii) The examination is to reveal a regular weld profile, through fusion between adjacent layers of weld and base metal, sufficient root penetration and the absence of defects such as cracks, lack of fusion etc.

- (g) Non-destructive inspection
  - (i) Test assemblies are to be examined for the whole length by visual and by non-destructive testing prior to the cutting of test specimen. Non destructive examinations should be carried out after any required post weld heat treatment, natural or artificial ageing, and prior to the cutting of the test specimens.
  - (ii) NDT procedures are to be agreed with the Society. The results of non-destructive testing are to show that there are no cracks or other injurious defects, and acceptance criteria is to be in accordance with **Annex 2-7** of the Guidance.

#### 404. Butt welded joints

##### 1. Kinds of test

"where found necessary by the Society" referred in **404. 2** of the Rules means where the properties are difficult to be investigated by test of **Table 2.2.4** of the Rules. **[See Rule]**

##### 2. Tensile test

(1) "where found necessary by the Society" referred in Note (1), **Table 2.2.4** of **404. 5** of the Rules means where the properties are difficult to be investigated by test of **Table 2.2.4** of the Rules. **[See Rule]**

##### 3. Impact tests

In application to Note (1), **Table 2.2.8** of **404. 6** of the Rules, impact test requirements for thickness above 50mm are in accordance with **Table 2.2.6** of the Guidance.

**Table 2.2.6 Impact test requirements for butt joints** (50 mm < t ≤ 70 mm)

Grade of steel	Test temp. (°C)	Value of minimum average absorbed energy (J)		
		For manually or semi-automatically welded joints		For automatically welded joints
		Downhand, Horizontal, Overhead	Vertical upward, Vertical downward	
<i>A</i> <sup>(1)</sup>	20	47 min.	41 min.	41 min.
<i>B</i> <sup>(1)</sup> , <i>D</i>	0			
<i>E</i>	-20			
<i>AH</i> 32, <i>AH</i> 36	20			
<i>DH</i> 32, <i>DH</i> 36	0			
<i>EH</i> 32, <i>EH</i> 36	-20			
<i>FH</i> 32, <i>FH</i> 36	-40	46 min.	46 min.	
<i>AH</i> 40	20			
<i>DH</i> 40	0			
<i>EH</i> 40	-20			
<i>FH</i> 40	-40			

Note:  
(1) For Grade A and B steels average absorbed energy on fusion line and in heat affected zone is to be minimum 27 J.

#### 405. Test for fillet welded joints

##### 1. Kinds of test

"if found necessary by the Society" referred in **405. 2** of the Rules means where the properties and defects are difficult to be investigated by test of the Rules. **【See Rule】**

#### 406. Retests and Procedure qualification records(PQR)

##### 1. Procedure qualification records(PQR)

In application to **406. 2** (1) of the Rules, the term "the discretion of the Society" means the acceptance in accordance with **Pt 1, Ch 1, 105.** of the Rules. **【See Rule】**

#### 407. Validity of qualified welding procedure specification

1. In application to **407. 2** (1), (8) (c) of the Rules, the terms "deemed appropriate by the Society" and "the discretion of the Society" mean the acceptance in accordance with **Pt 1, Ch 1, 105.** of the Rules. *(2019)* **【See Rule】**

---

## Section 5 Welders and Welder Performance Qualification Scheme (2018)

### 503. Testing procedure

#### 1. Examination and test

- (1) "at the discretion of the Society" referred in Note (6), **Table 2.2.17** of **503. 3** of the Rules means where the soundness for test specimens and welder qualification are difficult to be verified by test of **Table 2.2.17** of the Rules. **【See Rule】**
- (2) In application to **503. 3** (3) (f) of the Rules, defects appearing at the corners of a test specimen during test can be investigated in accordance with **Pt 1, Ch 1, 105.** of the Rules. **【See Rule】**

### 504. General requirements for qualification validity

#### 1. Maintenance of the approval (2019) (2022) **【See Rule】**

- (1) When **504. 2** (1) (C) of the Rules is selected as the method of revalidation for welder qualification, it may be replaced by the followings.
  - (A) Quality system of shipyards/manufacturer is to comply with **ISO 3834-2** or equivalent requirements and is to be approved and maintained by third party.
  - (B) It is to be confirmed by the Society that **504. 2** (1) (C) (a) and (c) of the Rules are satisfied.
  - (C) Through the confirmation of (A) and (B) above, this revalidates the welder's qualifications for an additional 3 years.



## Section 6 Welding Consumables

### 601. General

#### 1. Application

In application to 601. 1 (3) of the Rules, the term "the discretion of the Society" means the acceptance in accordance with Pt 1, Ch 1, 105. of the Rules. **【See Rule】**

### 602. Electrodes for manual arc welding for normal strength steels, higher strength steels and steels for low temperature service

#### 1. Application

In application to 602. 1 (2) of the Rules, the term "the discretion of the Society" means the acceptance in accordance with Pt 1, Ch 1, 105. of the Rules. **【See Rule】**

#### 2. General provisions for tests

Hot cracking test specified in 602. 3 (1) of the Rules is to be done as follows : **【See Rule】**

(1) Test assemblies are to be T-joint shape as shown in Fig 2.2.5 of the Guidance. The bottom of the vertical plate is to grind straight, and adhere closely on the surface of horizontal plate. All surface rough(凹凸) on the plate is to be removed before welding. The tack welds in preparation for the fillet welds is to make at the both ends of the plate. Three transverse stiffeners are to reinforce the horizontal plate to prevent welding deformation.

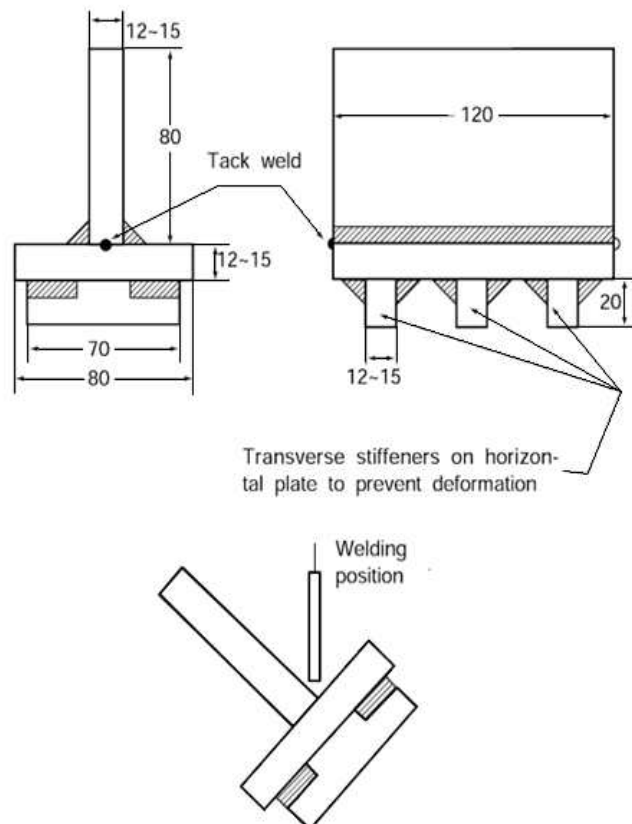


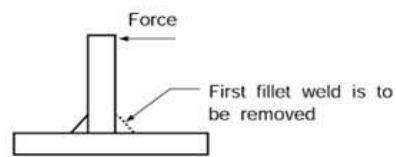
Fig 2.2.5 Hot Cracking Test Assemblies (Units : mm)

(2) The number of test assembly is to be prepared for every each diameter (4 mm, 5 mm or 6 mm) of electrodes.

- (3) The fillet welding is to be carried out in the downhand position in one pass on each side and the welding current used is to be the maximum of the range recommended by the manufacturer for the size of electrode used.
- (4) The second fillet weld is to be started immediately after the completion of the first fillet weld from the end of the test specimen at which the first fillet weld was finished. Both fillet welds are to be executed at a constant speed and without weaving.
- (5) Length of fused electrode in hot cracking test are to be as shown **Table 2.2.7** of the Guidance according to the diameter of electrodes.
- (6) After welding, the slag is to be removed from the fillet welds and after complete cooling, they are to be examined for cracks by a magnifying glass or by using penetrant fluids.
- (7) The first fillet weld is then to be removed by machining or gouging and the second weld broken by closing the two plates together, subjecting the root of the weld to tension (See **Fig 2.2.6** of the Guidance). The weld is then to be examined for evidence of hot cracking.

**Table 2.2.7 Length of Fused Electrode in Hot Cracking Test** (Units : mm)

Diameter of electrode	Length of fused electrode	
	1st fillet	2nd fillet
4	Approx. 200	Approx. 150
5	Approx. 150	Approx. 100
6	Approx. 100	Approx. 75



**Fig 2.2.6 Hot Cracking Test**

- (8) There is to be no cracking in the fillet welds either superficial or internal except crater crack.

### 3. Fillet weld test

In application to **602. 7** (3) of the Rules, the term "those deemed appropriate by the Society" means the acceptance in accordance with **Pt 1, Ch 1, 105.** of the Rules. **[See Rule]**

## 606. One side welding consumables for normal strength steels, higher strength steels and steels for low temperature service

### 1. Application

In application to **606. 1** (2), (3) of the Rules, the term "deemed appropriate by the Society" means the acceptance in accordance with **Pt 1, Ch 1, 105.** of the Rules. **[See Rule]**

## 607. Welding consumables for stainless steels

### 1. Welding consumables for duplex stainless steels

In application to **607. 1** (2) of the Rules, the approval tests and annual inspections for welding consumables used for duplex stainless steels (hereinafter referred to as "welding consumables") are to comply with the followings: **[See Rule]**

#### (1) General

Approval test items, test methods and acceptance criteria not specified in this Instruction are to be in accordance with **Ch 2, Sec 2 607.** of the Rules.

#### (2) Grades and marks

- (a) Welding consumables are classified as specified in **Table 2.2.8** of the Guidance.

**Table 2.2.8 Grades and Marks of Welding Consumables**

Electrode for manual arc welding	Material for TIG and MIG welding	Flux cored wire semi-automatic welding	Consumables for submerged welding
<i>RD31803</i>	<i>RY31803</i>	<i>RW31803</i>	<i>RU31803</i>
<i>RD32750</i>	<i>RY32750</i>	<i>RW32750</i>	<i>RU32750</i>

(b) Grades and marks not specified in the preceding (a) are to be in accordance with **Pt 2, Ch 2, 607. 2** of the Rules.

**(3) General provisions for tests**

(a) General provisions for tests are to be in accordance with **Pt 2, Ch 2, 607. 3** of the Rules.

(b) Steel plates to be used in preparation of test assemblies are to be as given in **Table 2.2.9** of the Guidance according to the grades of welding consumables.

**Table 2.2.9 Grades of Steel for Test Assembly**

Grade of welding consumables	Grade of steel for test assembly <sup>(1)</sup>
<i>RD31803, RY31803, RW31803, RU31803</i>	<i>RSTS31803</i>
<i>RD32750, RY32750, RW32750, RU32750</i>	<i>RSTS32750</i>
NOTE: (1) Notwithstanding the requirements in this table, mild steel or higher strength steel may be used for deposited metal test assembly. In this case, test assemblies are to be appropriately buttered.	

**(4) Deposited metal test**

(a) The chemical composition of the deposited weld metal shall be determined by the manufacturer and reported the results of the analysis to the Society. The report is also to include the main alloy elements. The results of the analysis shall not exceed the limit values specified in the standards or by the manufacturer, the narrower tolerances being applicable in each case.

(b) The tensile strength, yield point and elongation of each test specimen shall meet the specified minimum value of the base material.

(c) Deposited metal impact tests

(i) One set of three impact test specimens, from each test assembly, are to be machined to dimensions charpy V-notch impact test specimens as shown in **Table 2.1.3** of Rules. The test specimen is to be cut with its longitudinal axis transverse to the direction of welding, and the test specimen is to coincide with the mid-thickness of the plate shown in **Fig 2.2.22** of Rules.

(ii) The notch is to be positioned in the centre of weld and is to be cut in the face of test specimens perpendicular to the surface of plate.

(iii) 27J at -20°C is to be satisfied.

(iv) When the absorbed energy of two or more test specimens among a set of test specimens is less in value than the specified average absorbed energy or when the absorbed energy of a single test specimen is less in value than 70 % of the specified average absorbed energy, the test is considered to have failed.

**(5) Butt weld test**

(a) The tensile strength, yield point and elongation of each test specimen shall meet the specified minimum value of the base material.

(b) Butt weld bend tests are to be in accordance with **Pt 2, Ch 2, 607. 3** of the Rules.

(c) Butt weld Impact test

(i) Kinds, numbers and selection method of the butt weld impact test specimens being taken from each test assembly are to comply with the requirements specified in **602. 5 (4), 603. 5 (4) or 604. 5 (4)** of Rules according to the grade of the welding consumables.

- (ii) 27J at  $-20^{\circ}\text{C}$  is to be satisfied.
  - (iii) When the absorbed energy of two or more test specimens among a set of test specimens is less in value than the specified average absorbed energy or when the absorbed energy of a single test specimen is less in value than 70% of the specified average absorbed energy, the test is considered to have failed.
- (6) **Corrosion resistance test**
- (a) The corrosion resistance test of downhand specimen for butt weld test is to be carry out in accordance with **ASTM G48** Method A. For 22Cr, test temperature is to be  $20^{\circ}\text{C}$  and the exposure time is to be minimum 24h. And for 25Cr, test temperature is to be  $40^{\circ}\text{C}$  and the exposure time is to be minimum 24h. (2020)
  - (b) Acceptance Criteria
    - (i) There is to be no pitting at 20 X magnification.
    - (ii) The weight loss is to be less than  $4.0 \text{ g/m}^2$ . (2020)
- (7) **Micro structure test**
- The ferrite content in the weld metal shall be determined in accordance with ASTM E 562 and shall be in the range of 25% to 70%.
- (8) **Annual inspections**
- Annual inspections are to be in accordance with **Pt 2, Ch 2, 607. 6** of the Rules.

## 2. General provisions for tests

In application to **607. 3** (1) of the Rules, the term "deemed necessary by the Society" means the acceptance in accordance with **Pt 1, Ch 1, 105.** of the Rules. **[See Rule]** ↕

## Annex 2-1 Guidance for seamless forged steel drums

### 1. Seamless forged steel drums

#### 1.1 Application

- (1) This requirements apply to seamless forged steel drums intended for boiler construction (hereinafter referred to as “forged drums”).
- (2) Items differing from those specified in this Guidance are to comply with the requirements in **Pt 2, Ch 1, Sec. 1** and **2** of the Rules.

#### 1.2 Kind

The forged drums are classified into grades as given in **Table 1**.

**Table 1 Kind**

Grades
<i>RSFB 410</i>
<i>RSFB 520</i>

#### 1.3 Mechanical properties

The forged drums are to comply with the following requirements.

##### (1) Tensile test

The forged drums are to conform to the requirements given by **Table 2** in the tensile test.

**Table 2 Tensile Test**

Grade	Yield strength (N/mm <sup>2</sup> )	Tensile strength (N/mm <sup>2</sup> )	Elongation (%) (L = 5D)	Reduction of area (%)
<i>RSFB 410</i>	205 min.	410 min.	24 min.	38 min.
<i>RSFB 520</i>	255 min.	520 min.	22 min.	40 min.

##### (2) Bend test

The test specimen is to stand being bent cold through 180 degrees without cracking outside to the inside radius given in **Table 3**.

**Table 3 Bend Inside Radius**

Grades	<i>RSFB 410</i>	<i>RSFB 520</i>
Bend inside radius	Tensile strength not more than 490 N/mm <sup>2</sup> : 6 mm	Tensile strength not more than 560 N/mm <sup>2</sup> : 9.5 mm
	Tensile strength over 490 N/mm <sup>2</sup> : 9.5 mm	Tensile strength over 560N/mm <sup>2</sup> : 16 mm

#### 1.4 Selection of test specimens

- (1) One set specimens each for tensile test and bend test are to be taken from each end of the forged drum, perpendicular to the centerline of the forged drum as well as opposite side each other with the centerline.
- (2) Only in the case where ends of the forged drums are closed by reforging after machining, the test coupon may be cut from the forged drum before the reforging and heat treated simultaneously with the forged drum. In such a case, the forged drum is to be heat treated again after reforging. The latter heat treatment is to be annealing at a temperature above the critical temperature but not above the temperature of the first annealing when the former heat treatment is annealing, and to be same treatment as the former when the former heat treatment is normalizing and tempering. ⚡

## Annex 2-2 Guidance for non-destructive testing of marine steel castings

### 1. Application

- (1) The requirements in this Guidance is intended to give general guidance on the extent, methods and recommended quality levels applicable to the non-destructive testing (NDT), of marine steel castings (hereinafter referred to as "castings") specified in **Pt 2, Ch 1, 501. 8** and **10** of the Rules, except in those cases where alternative criteria have been otherwise approved or specified.
- (2) Although no detailed Guidance are given for machinery components, the requirements in this Guidance may apply correspondingly considering their materials, kinds, shapes and stress conditions being subjected.
- (3) Castings should be examined in the final delivery condition. *(2021)*
- (4) Where intermediate inspections have been performed the manufacturer should provide reports of the results upon the request of the Surveyor. *(2021)*
- (5) Where a casting is supplied in semi-finished condition, the manufacturer should take into account the quality level of final finished machined components. *(2021)*
- (6) Where advanced ultrasonic testing methods are applied, e.g. PAUT or TOFD, reference is made to **Annex 2-12**, for general approach in adopting and application of these advanced methods. Acceptance levels regarding accept/reject criteria are specified in this Guidance. *(2021)*

### 2. Personnel Requirements *(2021)*

- (1) Personnel engaged in visual examination are to have sufficient knowledge and experience, however, may be exempted from formal qualifications specified in this Recommendation.
- (2) Personnel carrying out NDT should be certified to a recognised national or international certification scheme, e.g. ISO 9712:2012, or an employer based scheme such as SNT-TC-1A:2016, or ANSI/ASNT CP-189:2016. Where employer based schemes are applied, personnel qualification to these schemes may be accepted if the written practice is reviewed and found acceptable by the Society. The written practice should align with the main requirements with those of ISO 9712 (apart from the impartiality requirements of a certification body).
- (3) Personnel responsible for the NDT activity including approval of procedures should be qualified and certified to Level III.
- (4) The NDT personnel's certificates and competence should comprise all industrial sectors and techniques being applied by the manufacturer or its subcontractors. Certificates should be made available to the Society for verification, when requested.
- (5) The operator carrying out the NDT and interpreting indications, should as a minimum, be qualified and certified to Level II in the NDT method(s) concerned. However, operators only undertaking the gathering of data using any NDT method and not performing data interpretation or data analysis may be qualified and certified as appropriate, at level I. The operator should have adequate knowledge of materials, weld, structures or components, NDT equipment and limitations that are sufficient to apply the relevant NDT method for each application appropriately.

### 3. Casting Condition

- (1) Non-destructive testing applied for acceptance purposes to support final casting certification should be made after the final heat treatment of the casting. Where intermediate inspections have been performed the manufacturer should provide reports of the results upon request of the Surveyor. *(2021)*
- (2) Castings should be examined in the final delivery condition free from any material such as scale, dirt, grease or paint that might affect the effectiveness of the inspection. A thin coating of contrast paint is permissible when using magnetic particle techniques. For surface inspection NDT methods, the surface quality should be a minimum value of  $Ra \leq 6.3 \mu\text{m}$ . *(2021)*
- (3) Ultrasonic testing should be carried out after the castings have been ground, machined or shot blasted to a suitable condition, with a minimum value surface quality of  $Ra \leq 12,5 \mu\text{m}$ . The surfaces of castings to be examined should be such that adequate coupling can be established between the probe and the casting and that excessive wear of the probe is avoided. *(2021)*

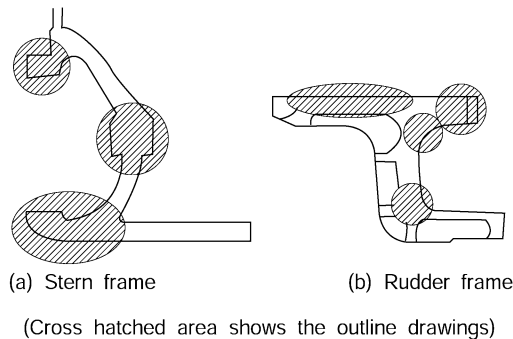
### 4. Extent of Inspections

#### (1) Castings to be examined

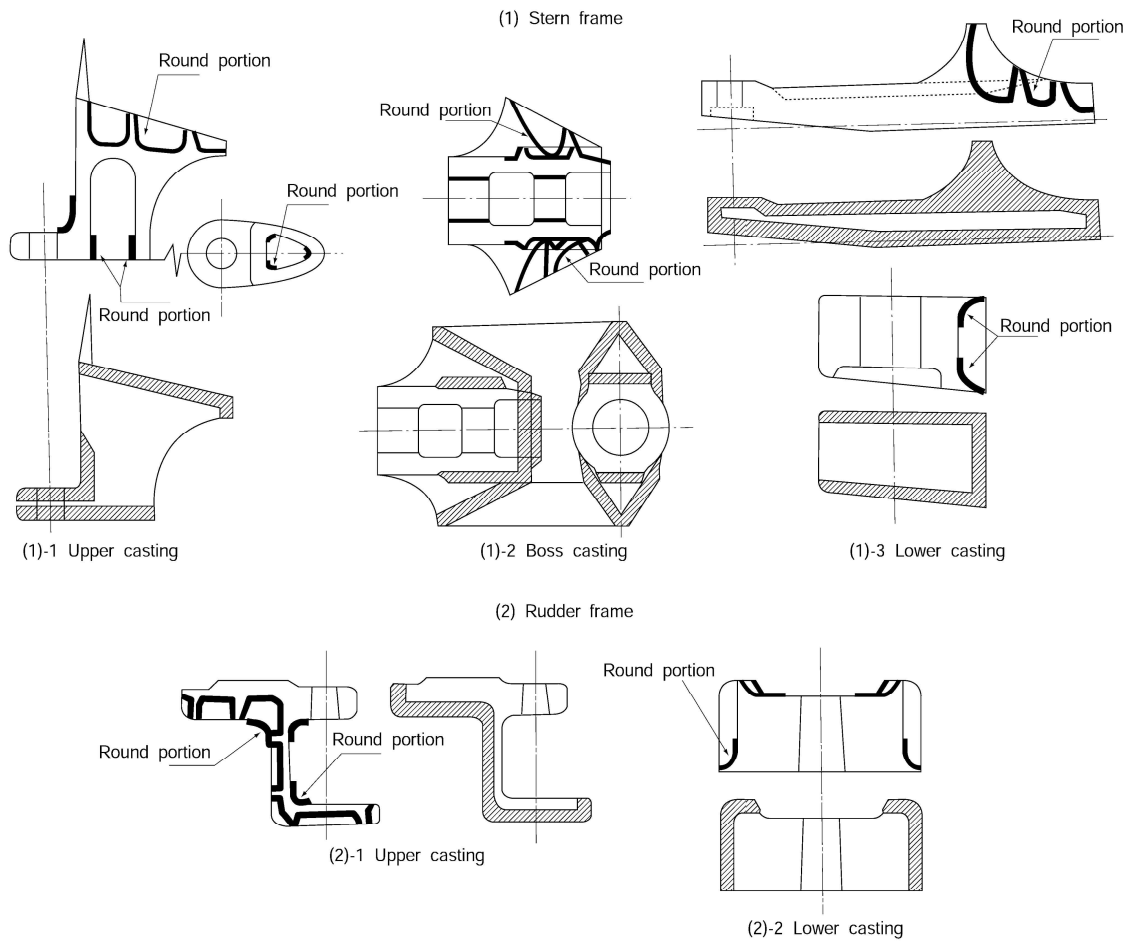
Castings to be examined by NDT methods are identified in **Fig 1** to **Fig 3** of this Guidance. Criteria for the examination of other castings not identified in **Fig 1** to **Fig 3** of this Guidance will be subject to agreement.

## (2) Zones to be examined

- (A) Zones to be examined in nominated castings are identified in **Fig 1** to **Fig 3** of this Guidance. Testing should be made in accordance with an inspection plan approved by the Society. The plan should specify the extent of the testing, the testing procedure, the quality level or, if necessary, level for different locations of the castings.
- (B) In addition to the areas identified in **Fig 1** and **Fig 2** of this Guidance, surface inspections should be carried out in the following locations:
- at all accessible fillets and changes of section,
  - in way of fabrication weld preparation, for a band width of 30mm,
  - in way of chaplets,
  - in way of weld repairs,
  - at positions where surplus metal has been removed by flame cutting, scarifying or arc-air gouging.
- (C) Ultrasonic testing shall be carried out in the zones indicated in **Fig 1** and **Fig 3** of this Guidance and also at the following locations:
- in way of all accessible fillets and at pronounced changes of section,
  - in way of fabrication weld preparations for a distance of 50 mm from the edge,
  - in way of weld repairs where the original defect was detected by ultrasonic testing.
  - in way of riser positions,
  - in way of machined areas particularly those subject to further machining such as bolt



**Fig 1 Detection Area for Non-destructive Test**



## (Notes)

1. The entire edge preparation shown with the hatched area and the 100 mm width from the areas outside are to be subjected to the tests.
2. The portions shown in thick lines are also to be subjected to the test.
3. The portions of feeding heads and gates of the castings are to be subjected to the test.

**Fig 2 Example of Application of Magnetic Particle Tests**



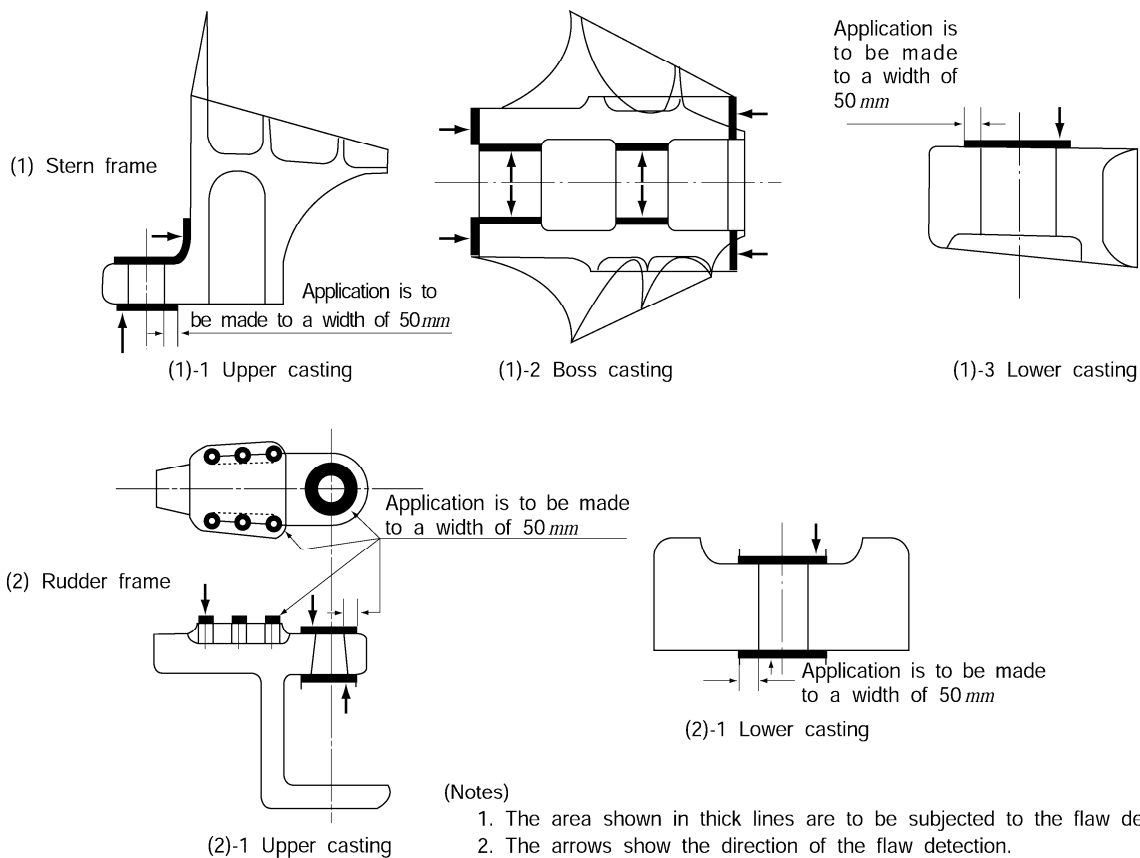


Fig 3 Examples of Application of Ultrasonic Tests

## 5. Examination Procedures

### (1) Visual Inspection

Steel castings nominated for NDT should be subjected to a 100% visual examination of all accessible surfaces by the manufacturer and made available to the Surveyor. Viewing conditions at the inspected surfaces should be in accordance with a nationally or internationally recognised standard. Unless otherwise agreed, the visual and surface inspections should be carried out in the presence of the Surveyor. (2021)

### (2) Surface Inspection

- (a) Magnetic particle testing is preferable to penetrant testing except in the following cases: (2021)
  - (i) austenitic stainless steels,
  - (ii) interpretation of open visual or magnetic particle indications,
  - (iii) at the instruction of the Surveyor, where a particular need for penetrant testing has been identified. (2021)
- (b) The testing procedures, apparatus and conditions of magnetic particle testing and liquid penetrant testing other than those specified in this Guidance are to comply with recognised national or international standards.
- (c) AC magnetisation method should normally be used, as it is more sensitive for detecting surface indications. Where DC magnetisation method is used, this should be in agreement with the Society, and the reason for use clearly stated. (2021)
- (d) Magnetic particle testing is to be carried out along two directions so that magnetic field can be directed at an right angle each other by means of the wet prod methods or the yoke method. In making magnetization by the prod method, the distance between prods is to be 200~300 mm. The magnetizing current is to be DC 800~1200 A for the prod method. For the yoke method, lifting power is to be 4.5 kg for AC, 18 kg over for DC.
- (e) For magnetic particle testing attention is to be paid to the contact between the casting and the clamping devices of stationary magnetisation benches in order to avoid local overheating

or burning damage in its surface. Prods should not be permitted on finished machined items. Note that the use of solid copper at the prod tips must be avoided due to the risk of copper contamination into the casting. The pole of the magnets should have close contact with the component. (2021)

- (f) When indications have been detected as a result of the surface inspection, acceptance or rejection should be decided in accordance with **Art 6**.

**(3) Volumetric Inspection**

- (a) Volumetric inspection in accordance with these guidance is normally to be carried out by ultrasonic testing using the contact method with normal( $0^\circ$ ) beam and/or angle beam technique. The testing procedures, apparatus and conditions of ultrasonic testing should comply with the recognised national or international standards. (2021)
- (b) In some cases, due to the shape, nature, complexity of casting, or defect type or orientation, there may be a need for radiographic testing. In such cases, radiographic testing may be carried out on the basis of prior agreement with the Society. Where radiographic testing is to be applied, national or international standards for both the testing method, and the quality or severity level to be applied, should be agreed with the Society. These following examples are suitable national or international standards as appropriate to the radiographic testing of castings, and casting thickness. (2021)
- ASTM E446-15
  - ASTM E186-15(2019) e1
  - ASTM E280-15(2019) e1
  - ISO 4993:2015

A suitable quality level for marine castings would normally be severity level 2 or 3 (of the above standards), depending on the location zone and type of casting. Other severity levels may be applied, and should be agreed with the Society. (2021)

- (c) Only those areas shown in the agreed inspection plan need to be tested, however, the inspections may reveal indications that require further evaluation, or an extension of testing. In such cases, this should be agreed with the Society. The plan should include those locations nominated in **4. (2)**, (c) together with the scanning zones identified for the relevant casting in **Fig 1** to **Fig 3**. (2021)
- (d) Ultrasonic scans should be made using a normal probe of 1~4 MHz (usually 2 MHz) frequency, and angle probes, where required. Whenever possible scanning is to be performed from both surfaces of the casting and from surfaces perpendicular to each other. (2021)
- (e) The back-wall echo obtained on parallel sections should be used to monitor variations in probe coupling and material attenuation. Any reduction in the amplitude of the back-wall echo due to material properties should be corrected. Attenuation in excess of 30dB/m could be indicative of an unsatisfactory annealing heat treatment, and may render the effectiveness of the testing as unsuitable. In such cases of excessive attenuation, this should be investigated, and suitable mitigation measures carried out for effective ultrasonic testing to continue, where possible. (2021)
- (f) Machined surfaces, especially those in the vicinity of riser locations and in the bores of stern boss castings, should also be subject to a near surface (approximately 25 mm) scan using a twin crystal  $0^\circ$  probe. Additional scans on machined surfaces are of particular importance in cases where bolt holes are to be drilled or where surplus material such as 'padding' has been removed by machining thus moving the scanning surface closer to possible areas of shrinkage. Additionally it is good practice to examine the machined bores of castings using circumferential scans with  $70^\circ$  probes in order that axial radial planar flaws such as hot tears can be detected. Fillet radii should be examined using  $45^\circ$ ,  $60^\circ$ , or  $70^\circ$  probes scanning from the surfaces/direction likely to give the best reflection, primarily to determine the presence of any cracks within the radiused areas, and as an additional scan to confirm any indications that may have been detected with  $0^\circ$  probe(s) within this area. (2021)
- (g) In the examinations of those zones nominated for ultrasonic examination the reference sensitivity for the  $0^\circ$  probe should be established against a 6mm diameter disk reflector. Sensitivity can be calibrated either against 6mm diameter flat bottomed hole(s) in a reference block (or series of blocks) corresponding to the thickness of the casting provided that a transfer correction is made, using the DAC(distance-amplitude-correction) method, or, by using the *DGS* (distance-gain-size) method. (2021)

- (h) The reference sensitivity of angle probes (where required for testing) should be established against an appropriate 6mm reflector (e.g. reference reflectors angled perpendicular to the sound beam) for the DAC method, or equivalent using the DGS method. (2021)
- (i) The DGS diagrams issued by a probe manufacturer identify the difference in dB between the amplitude of a back wall echo and that expected from a 6mm diameter disk reflector. By adding this difference to the sensitivity level initially set by adjusting a back wall echo to a reference height e.g. 80 %, the amended reference level will be representative of a 6mm diameter disk reflector. Similar calculations can be used for evaluation purposes to establish the difference in dB between a back wall reflector and disk reflectors of other diameters such as 12 or 15 mm.
- (j) Having made any necessary corrections for differences in attenuation or surface condition between the reference block and the casting any indications received from the nominated zones in the casting that exceed the 6mm reference level should be marked for evaluation against the criteria given in 6. (3) below. Evaluation should include additional scans with angle probes in order that the full extent of the discontinuity can be plotted.

## 6. Acceptance Criteria

### (1) Visual Inspection

- (a) All castings should be free of cracks, crack-like indications, hot tears, cold shuts or other detrimental indications. Thickness of the remains of sprues or risers should be within the casting dimensional tolerance. (2021)
- (b) Additional magnetic particle, penetrant or ultrasonic testing may be required for a more detailed evaluation of surface irregularities at the request of the Surveyor.

### (2) Surface Crack Detection

- (A) The following definitions relevant to indications apply:
  - (a) Linear indication : an indication with a largest dimension three or more times its smallest dimension (i.e.  $l \geq 3w$ ). (2021)
  - (b) Non-linear indication : an indication with a largest dimension less than three times its smallest dimension (i.e.  $l < 3w$ ). (2021)
  - (c) Aligned indication : three or more indications in a line, separated by 2 mm or less edge-to-edge, which results in a unique indication, defined as follows: (2021)
    - (i) Non-linear indications form an alignment when the distance between indications is less than 2mm and at least three indications are aligned. An alignment of indications is considered to be a unique indication and its length is equal to the overall length of the alignment.
    - (ii) Linear indications form an alignment when the distance between two indications is smaller than the length of the longest indication.
  - (d) Open indication : an indication visible after removal of the magnetic particles or that can be detected by the use of penetrant testing.
  - (e) Non-open indication : an indication that is not visually detectable after removal of the magnetic particles or that cannot be detected by the use of contrast dye penetrant testing.
  - (f) Relevant indication : an indication that is caused by a condition or type of discontinuity that requires evaluation. Only the indications which have any dimension greater than 1.5 mm should be considered relevant for the categorization of indications. (2021)
- (B) For the purpose of evaluating indications, the surface should be divided into reference band length of 150 mm for level MT1/PT1 and into reference areas of 225 cm<sup>2</sup> for level MT2/PT2. The band length and/or area should be taken in the most unfavourable location relative to the indications being evaluated.
- (C) The following quality levels recommended for magnetic particle testing (MT) and/or penetrant testing (PT) are;

Level MT1/PT1 – fabrication weld preparation and weld repairs.

Level MT2/PT2 – other locations nominated for surface inspection in **Fig 1** and **Fig 2**

The allowable numbers and sizes of indications in the reference band length and/or area are given in **Table 1**. The required quality level should be shown on the manufacturer's in-

spection plan. Cracks and hot tears should not be accepted.

**Table 1 Allowable number and size of indications in a reference band length/area (2021)**

Quality Level	Total maximum number of all indications	Type of indication	Maximum number of each type of indication	Maximum dimension of single indication, (mm) <sup>(2)</sup>
MT1/PT1	4 in 150 mm length	Non-linear	4 <sup>(1)</sup>	5
		Linear	4 <sup>(1)</sup>	3
		Aligned	4 <sup>(1)</sup>	3
MT2/PT2	20 in 22500 mm <sup>2</sup> area	Non-linear	10	7
		Linear	6	5
		Aligned	8	5

Notes:  
 (1) 30 mm minimum(measured in any direction) between relevant indications.  
 (2) In weld repairs, the maximum dimension is 2 mm.

### (3) Volumetric Inspection

- (A) Acceptance criteria for ultrasonic testing are identified in **Table 2** as UT1 and UT2. As stated in **4 (2), (a)**, the quality levels applicable to the zones to be examined should be identified on an inspection plan. The following quality levels are nominated for the castings identified in **Fig 1** and **Fig 3**.

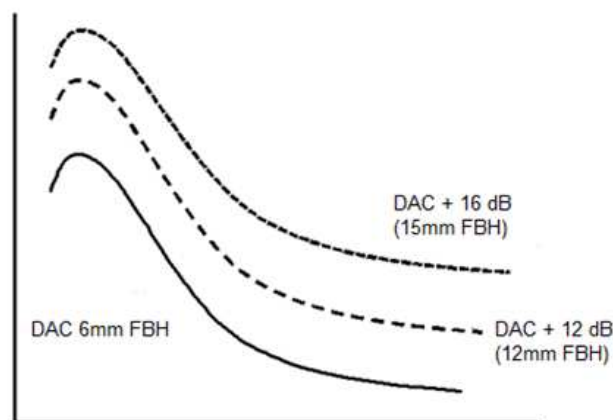
**Table 2 Ultrasonic Acceptance Criteria for steel castings (2021)**

Quality Level	Allowable disc shape according to <i>DGS</i> <sup>(1)</sup> (mm) or diameter of FBH according to DAC <sup>(2)(3)</sup> Curve(mm)	Maximum number of indications to be registered <sup>(4)</sup>	Allowable size of all relevant indications (mm) <sup>(5)(6)</sup>
UT1	>6	0	0
UT2	12–15	5	50
	>15	0	0

Notes:  
 (1) DGS: distance–gain size.  
 (2) DAC: Distance Amplitude Correction  
 (3) The corresponding DAC level to each of the FBH reflectors is at 100% DAC  
 (4) grouped in an area measuring 300 x 300 mm  
 (5) measured on the scanning surface  
 (6) the measured indication is regarded as the longest dimension, as measured in the scanning process

- (B) Level UT1 is applicable to:  
 (a) fabrication weld preparations for a distance of 50 mm,  
 (b) 50 mm depth from the final machined surface including bolt holes and fillet radii to a depth of 50 mm and within distance of 50 mm from the radius end,  
 (c) castings subject to cyclic bending stresses e.g. rudder horn, rudder castings and rudder stocks – the outer one third of thickness in the zones nominated for volumetric inspection by **Fig 1** and **Fig 3**.  
 (d) discontinuities within the examined zones interpreted to be cracks or hot tears.
- (C) Level UT2 is applicable to:

- (a) other locations nominated for ultrasonic testing in **Fig 1** and **Fig 3** or on the inspection plan.
- (b) positions outside locations nominated for level UT1 examination where feeders and gates have been removed
- (c) castings subject to cyclic bending stresses – at the central one third of thickness in the zones of nominated for volumetric inspection by **Fig 1** and **Fig 3**.
- (D) For near surface testing (to an approximate depth of 25 mm) twin crystal 0° (normal beam) probe should be used, plus a 0° probe (usually single crystal beyond a depth of 25 mm) for the remaining volume. (2021)
- (E) Ultrasonic acceptance criteria for other casting areas not nominated in **Fig 1** and **Fig 3** should be subject to special consideration based on the anticipated stress levels and the type, size and position of the discontinuity.
- (F) DGS and DAC methods may be used for determining sensitivity. The DAC method for normal beam probes may be based on a 6.0 mm diameter reflector or flat bottomed hole (FBH). A DAC curve should be produced using reference blocks containing 6.0 mm FBH reflectors over a range representative of the inspection thickness, after adjustment for transfer and attenuation losses, (2021)
- (G) For quality level UT 1, any discontinuity producing a signal amplitude in excess of the 6.0 mm DAC curve is unacceptable. (2021)
- (H) For quality level UT2, the sensitivity may be based on actual size FBH (of 12 mm and 15 mm) or based on equivalent 6 mm FBH, and the sensitivity adjusted to obtain equivalent amplitudes, as described in (I). (2021)
- (I) For use of FBH of 6 mm for setting sensitivity, adjustment of signal amplitudes (measured in dB above 6 mm DAC) can be determined for 12 mm and 15 mm FBH reflectors: to be DAC + 12dB and DAC + 16dB (plus any compensation for transfer and attenuation losses). This is illustrated in Figure 1. The increase in dB to the indicated levels represent the equivalent FBH sizes (for 12 mm and 15 mm), and their respective corresponding ultrasonic response amplitudes. (2021)
- (J) The maximum number of indications to be registered and the maximum length of indications permissible for quality level 2 (as stated in **Table 2**) apply to normal probes. (2021)
- (K) For quality level UT 2, any discontinuity producing a signal amplitude in excess of the 15.0 mm DAC curve should be regarded as unacceptable. (2021)
- (L) Any signal between 12 + 15 curve should be evaluated for length of defect, and referred to **Table 2** for acceptance. (2021)



(Notes)

- (1) The bottom curve (DAC) represents a sensitivity based on 6mm FBH, and the two additional curves (DAC + 12 and DAC + 16dB) above this represent the equivalent sensitivities converted for larger FBH's (12mm and 15mm).
- (2) When scanning using these curves, and applying **Table 2** acceptance criteria, for UT2, any indication below DAC +12mm should be disregarded, and any indication above DAC +16mm should be rejected.
- (3) Any indication between these two curves should be evaluated according to its size, as per **Table 2**.

**Fig 4** DAC curve produced from 6.0 mm FBH reflector and DAC curves adjusted to represent equivalent 12.0 mm and 15.0 mm FBH reflectors

## 7. Reporting

- (1) All reports of non-destructive examinations should include the following items:
  - (a) Date of testing.
  - (b) Name(s), signature(s) and qualification level of inspection personnel. (2021)
  - (c) Type of casting.
  - (d) Product number and unique identification. (2021)
  - (e) Grade of steel.
  - (f) Heat treatment.
  - (g) Stage of testing.
  - (h) Locations for testing.
  - (i) Surface condition.
  - (j) Test standards used including reference to the appropriate tables for acceptance purposes (2021)
  - (k) Results including documentation regarding the repair and testing history(as appropriate); (2021)
  - (l) Statement of acceptance / non-acceptance.
  - (m) Locations of reportable indications.
  - (n) Details of weld repairs including sketches(where applicable). (2021)
- (2) In addition to the items listed in 7 (1), reports of surface inspections should include at least the following items:
  - (a) for liquid penetrant testing; the penetrant system used, (2021)
  - (b) for magnetic particle testing: method of magnetising, test media and magnetic field strength and magnetic flux indicators(where appropriate). (2021)
  - (c) viewing conditions (as appropriate to the penetrant or magnetic technique and media used) (2021)
  - (d) testing details and procedure number (2021)
  - (e) details of any test restrictions (2021)
- (3) In addition to the items listed in 7 (1), reports of ultrasonic inspection should include at least the following items:
  - (a) flaw detector probe type, size, angle and frequency (and any adaptations to probes for curved surfaces), calibration and reference blocks, sensitivity method (including reflector size, transfer correction), maximum scanning rate (mm/s), and couplant. (2021)

## 8. Rectification of Defects

### (1) General

- (a) Indications that exceed the requirements of **Table 1** and **Table 2**, should be classed as defects, and should be repaired or rejected as appropriate. (2021)
- (b) In either case where, after removing defects, the steel castings are used as they are or repair welding are carried out approval of the surveyor is to be obtained. In case where the depth of the recess after removing the defects is not larger than 15 mm (or 10 % of the thickness of the steel castings, whichever is smaller) and the length is not more than 100 mm, the steel castings may be used without repair welding.
- (c) Castings which are repaired should be examined by the same method as at initial inspection, as well as by any additional methods as requested by the Surveyor. (2021)

### (2) Rectification of Defects

Defective parts of material are to be completely removed either by grinding, or by chipping and grinding, or by arc air-gouging and grinding and to be repaired by either of the following methods. Thermal methods of metal removal should only be allowed before the final heat treatment. However, if there is a track record used on the ship by repairing in a different way, or if the Surveyor satisfies the repair method according to national or international standards, the other repair method may be acceptable. (2021)

#### (A) In case of no repair welding being carried out

The portions required no repair welding after removing defects, are to be finished with a grinder etc. in accordance with the following:

- (a) All grooves shall have a bottom radius of approximately three times the groove depth.
- (b) Grooves and their vicinity are to be finished smoothly avoiding abrupt changes in configuration.
- (c) The portions where defects have been removed are to be verified that they are free from harmful defects by liquid penetrant test or magnetic particle test after finishing of

the surface configuration.

- (B) The portions required repair welding are to be suitably shaped and verified that they are free from harmful defects by nondestructive tests specified in (2) (A) (c) above and also repaired in accordance with the requirements in 3. of this Appendix. Weld repairs should be suitably classified as follows.:

(a) *Major repairs*

- (i) where the depth is greater than 25 % of the wall thickness or 25 mm whichever is less,
- (ii) where the total weld area on a casting exceeds 2 % of the casting surface noting that where a distance between two welds is less than their average width, they are to be considered as one weld.
- (iii) Major repairs require the approval of the Society before the repair is carried out. The repair should be carried out before final furnace heat treatment.

(b) *Minor repairs*

- (i) where the total weld area (length x width) exceeds 500 mm<sup>2</sup>
- (ii) Minor repairs do not usually require the approval of the Society but should be recorded on a weld repair sketch as a part of the manufacturing procedure documents. These repairs should be carried out before final furnace heat treatment.

(c) *Cosmetic repairs*

- (i) all other welds.
- (ii) Cosmetic repairs do not require the approval of the Society but should be recorded on a weld repair sketch. These repairs may be carried out after final furnace heat treatment but are subject to a local stress relief heat treatment.

(3) **Procedure of repair welding**

The procedure of repair welding is to be as follows.

(A) **Welders**

Welders intended to engage in repair work by welding are to pass the qualification tests of the Society.

(B) **Welding consumables**

The welding consumables are to be either low hydrogen type approved by the Society or those deemed equivalent.

(C) **Preheating**

- (a) In cases where the carbon equivalent of the steel castings exceeds 0.44 %, the portions of repair welding and their vicinity are to be preheated to a temperature higher than 200°C. In this case, the carbon equivalent is to be calculated by the following formula.

$$C_{eq} (\%) = C + \frac{Mn}{6} + \frac{Si}{24} + \frac{Ni}{40} + \frac{Cr}{5} + \frac{Mo}{4} + \frac{V}{14}$$

- (b) Even in case where carbon equivalent is 0.44 % or less, preheating may be required taking into account the shape and size of the steel castings.

(D) **Position of welding**

The positions of welding are to be as given in the following **Table 3** in general.

**Table 3 Position of Welding**

Kind \ Position welding	Flat	Vertical	Horizontal	Overhead
	Manual welding	○	○	○
Semi-automatic welding	○	—	○	—

(E) **Post weld heat treatment**

- (a) Post weld heat treatment may be exempted in the following cases, provided that the carbon equivalent does not exceed 0.44 %.

- (i) In case where the depth of chipping after the removal of defects is not more than 25 mm (or 20 % of the thickness, whichever is smaller) and the length is not more

than 200 mm.

(ii) In cases where the depth of chipping after the removal of defects is not more than 15 mm and also the area is not more than 250,000 mm<sup>2</sup>

(b) Post weld heat treatment is to be carried out in furnaces. The holding temperature is to be 550°C~650°C and the period is to be not less than one hour per every 25 mm of welding depth. In case where annealing in furnace is impossible depending on the final condition of the steel castings to be finished, etc. or where the welding depth is not more than 50 mm as well as the length is not more than 300 mm, partial post weld heat treatment may be accepted as an alternative. By the partial post weld heat treatment, the welded portions and their vicinity within 100 mm therefrom are to be heated to a temperature not lower than 600°C and kept at the temperature in a period not less than 10 minutes per every 25 mm of the welding depth, and then to be cooled gradually.

**(F) Finishing after repair welding**

The portions repaired by welding are to be finished by grinding, etc. so that inspection can be available.

**(G) Inspection after repair welding**

Parts which are repaired should be examined by the same method as at initial inspection as well as by additional methods as required by the Surveyor. ↓



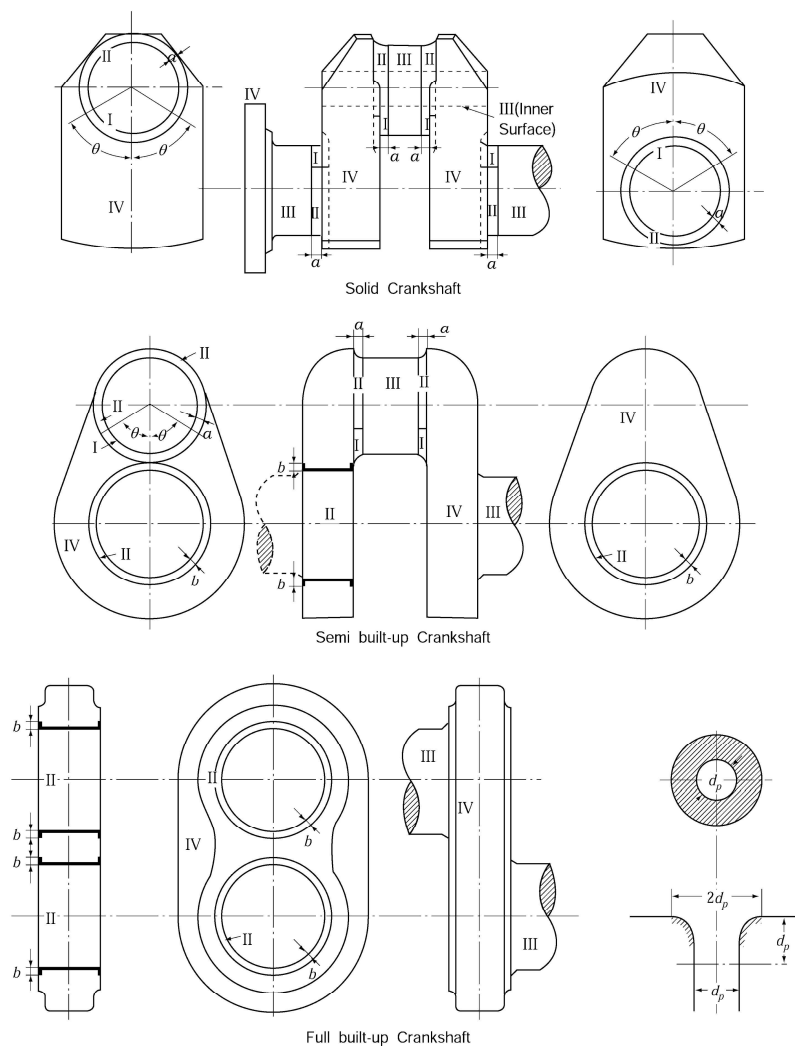
## Annex 2-3 Guidance for surface inspection of cast steel crankshafts

### 1. Application

- (1) This Guidance provides for the surface inspection of the cast steel crankshaft to be carried out on completion of machining (for shrunk parts, before shrinkage).
- (2) The surface inspection is to be carried out by the methods specified in **3**. Where defects were found as a result of the inspection, the Surveyor is to decide pass or rejection of the crankshaft by the standards for allowable limit of defects prescribed in **6**.
- (3) The inspection during the intermediate stage under construction is to be carried out actively by the manufacturer. The inspection methods are prescribed in **4**.
- (4) NDE personnel requirements and inspection plans are to comply with the requirements specified in **Annex 2-2, 2** and **4 (2) (a)** of this Guidance.

### 2. Divisions for inspection surface

The inspected surface of the crankshaft is divided into the following I to IV zones as shown in **Fig 1**. The inspection methods and standards are specified depending on the zones respectively.



(Notes)

1. Where the crankpin or journal has oil holes, the circumferential surface of the oil holes should be divided into division II (See the figure).
2.  $d$  : Diameter of crankshaft,  $\theta = 60^\circ$ ,  $\alpha = 0.1d$ ,  $b = 0.05d$  (but not less than 25 mm)

Fig 1 Divisions for Inspection Surface

### 3. Methods of inspection

- (1) The surface is to be inspected as under in accordance with Divisions for inspection surface prescribed in **2**. But where CC defects (refer to **Table 1**) have been detected as a result of the inspection, the Surveyor may demand ultrasonic inspection additionally.

Kinds	Inspections
Zone I and II	Magnetic particle inspection or dye penetrant inspection
Zone III and IV	Visual inspection

(Notes)

1. Regarding the parts used as forged or cast condition, it is to be subjected to magnetic particle inspection notwithstanding the above requirement.
2. Regarding the Zone III of the crankshaft to which quenching and tempering heat treatments are applied, or the same zone of the crankshaft to which surface hardening treatment is applied, it is to be subjected to either magnetic particle inspection or dye penetrant inspection notwithstanding the above requirement.

- (2) The methods of magnetic particle inspection, dye penetrant inspection and visual inspection are to be as deemed appropriate by the Society.

### 4. Inspection during intermediate stage

- (1) The manufacturer is recommended to carry out actively ultrasonic inspection for the crankshaft at the appropriate stage during the manufacturing process and prove that the crankshaft has no harmful defects internally.
- (2) The manufacturer should carry out actively the surface inspection at each stage under production. As the results when harmful defects of the material were found, the manufacturer is to inform the Surveyor of the facts and obey his instruction. Regarding cast steel crankshafts, when accepted by the Surveyor, defects can be remedied by welding according to the **Annex 2-4**.
- (3) Regarding the crankshaft which surface hardening treatment is taken, the manufacturer is actively to inspect the surface. The records of surface inspection are to be submitted to the Surveyor when he requires.

### 5. Standards for surface inspection

- (1) When defects have been detected as a result of the surface inspection prescribed in **3**, pass or rejection is to be decided by the following **6**, considering the results of the inspection of **4**. But even those which have failed to comply with these limits may be taken as passed, if in consideration with the position, size, direction and nature of the defects as well as the shape and dimension of such crankshafts, and the Surveyor accepted justifiable. Conversely, even those which have complied with these limits would be disqualified if they should contain such numerous defects as to make them unsuitable as crankshaft from the nature, distribution and direction of the defects.
- (2) The treatment of defects for surface inspection is to be as the followings:
  - (A) The lengths of the defects in the Standards are the actual lengths appeared by visual inspection.
  - (B) The defects can be removed after acceptance of the Surveyor.
  - (C) Removal of defects is to be carried out by grinding.
  - (D) Where two defects spaced less than 5 mm apart, these are to be removed regarding as one defect.
  - (E) The grooves caused by removing are to be smoothly rounded off by as large radius as possible toward the shaft surface.
  - (F) The size of grooves caused by removing means the size before rounding off
  - (G) Regarding cast steel crankshafts, when accepted by the Surveyor, defects can be remedied by welding according to the **Annex 2-4**.
  - (H) When defects were removed, it is to be confirmed that the defects have been completely removed by magnetic particle inspection or dye penetrant inspection.

- (l) Regarding the crankshaft which defects are left and removed, the manufacturer is to make detailed inspection records and submit the same to the Surveyor. In these inspection records, the position, size, direction and nature of the defects on the inspected surface and the position and size of grooves caused by removing the defects is to be recorded.

**6. Standards for allowable limit of defects for surface inspection**

(1) *Application*

- (a) The standards are to be applied to the semi built up cast steel and full built up crankshafts.  
(b) Defects specified in this Guidance are Grade CC shown in (B).

(2) *Classification of material defects*

The surface defects are classified as the following **Table 1**, but Grade CA and CB defects are excluded from consideration by this Guidances.

**Table 1 Classification of Material Defects**

Classification	Names of defects
Grade CA defects	Microscopic non-metal inclusion
Grade CB defects	Pin hole and inclusion which do not exceed 0.2 mm in length
Grade CC defects	· Exceed 0.2 mm in length, Pin-hole, blowhole, sand-inclusion, slag inclusion · Shrinkage cavity, · Hot tear, cold crack

(3) *Standards*

For Standards, **Table 2** is to be applied.

**Table 2 Standards**

Divisions	Standards
I	All defects which are detected are to be removed. The depth of grooves caused by such removing is to be less than $0.01d$ . In this case, the fillet parts are to be so finished that the original shape is retained. For parallel and plane parts, the grooves are to be so rounded off that the bottom radius of the grooves is not less than three times the depth of the groove.
II	All defects which are detected are to be removed, except the following defects: (i) Defects not exceeding 1 mm which are not crowded. (ii) Defects not exceeding 3 mm with sufficient spacing between each two. The depth of grooves caused by such removing is to be less than $0.01d$ , and the grooves are to be so rounded off that the bottom radius of the grooves is not less than three times the depth of the groove, and in no case it shall be less than twice the depth.
III	All defects which are detected are to be removed, except the following defects: (i) Defects not exceeding 3 mm which are not crowded. (ii) Defects not exceeding 5 mm with sufficient spacing between each two. The depth of grooves caused by such removing is to be less than $0.01d$ , and the grooves are to be so rounded off that the bottom radius of the grooves is not less than twice the depth of the groove.
IV	All defects which are detected are to be removed, except those not exceeding 8 mm. The depth of grooves caused by such removing is to be such that it does not affect the strength of the zone, and for the depth, it is necessary to receive the Surveyor's approval.



## Annex 2-4 Guidance for repairs by welding for cast steel crank throws

### 1. Applications

- (1) Where defects are discovered in the crank throws of cast steel crankshafts under manufacture (including full built-up crank webs: hereafter called, the crank throws), repairs by welding may be carried out in accordance with the following standards. However where the depth of the depression from which all defects have been removed is less than  $0.05t$  ( $t$  is the web's thickness), it is recommended that no repairs by welding be carried out. In this case the finishing of the base part of the depression shall be such that the rounding there is over twice the depth of the depression, and the angle between it and surface is sufficiently rounded up.
- (2) When the manufacturer desires to carry out repairs by welding, he shall apply in advance to the Surveyor for approval. In the case the Surveyor has found that such repairs by welding are not suitable or has perceived that there are too many places to be welded in such repairs, he will not approve the application, advising scrapping of the crank throw in question.
- (3) When the manufacturer desires to carry out repairs by welding, he shall arrange in advance for the crank throw to be subjected to the preliminary tests stipulated in 7 below.

### 2. The scope and conditions permitting repairs

- (1) The base part of the pin and web : Repairs by welding are not to be carried out the crosshatch zones marked on **Fig 1**.
- (2) The depth of the depression from which all defects have been removed is to be less than  $0.1t$ .

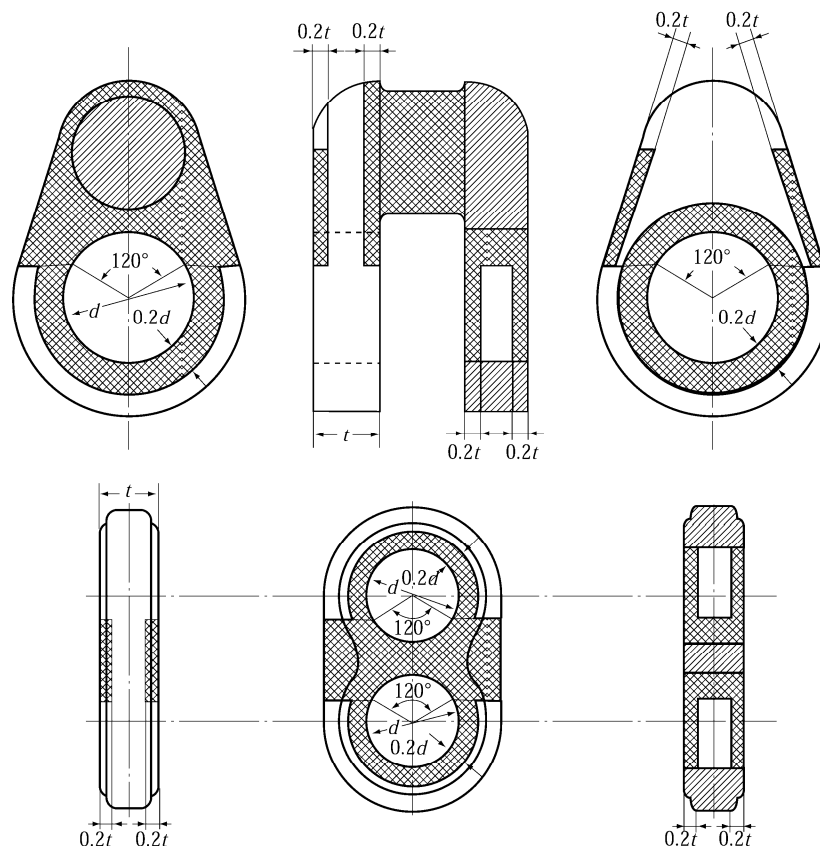


Fig 1 Zones where Repairs of Welding should not be carried out (Cross hatching zone)

### 3. Timing for repairs

Repairs by welding are to be carried out before the crank throws being given a formal heat treatment. However when approved by the Surveyor the weld repairing of comparatively minor defects may be carried out after the formal heat treatment.

#### 4. Methods of repairs

Repairs by welding are to be carried out in conformity with the requirements of the following items:

(1) **Welder**

The welder engaging in repairs shall be the one who has passed the qualification tests of the Society and who has further had the experience in the preliminary tests stipulated in 7 below.

(2) **Removal of defects**

After defects have been removed by grinding or gouging, the depression is to be made shapely so as to fit for welding; while it is to be confirmed that the defects have been completely removed by means of the magnetic particle inspection or dye penetrant inspection.

(3) **Preheating**

The part undergoing the weld repairing and its neighbourhood are to be preheated to temperatures exceeding 200°C.

(4) **Welding method**

Welding is to be the downhand electric arc welding.

(5) **Electrode**

The low hydrogen electrode approved by the Society is to be used.

(6) **Post heating**

On completion of welding the crank throws are to be heat-treated as specified, but those heat-treated formally previous to repairs by welding with the approval of the Surveyor may require the annealing process only used 600 – 650°C for stress relief.

(7) **Finish after repairs**

The repaired part shall be finished smoothly by grinding.

#### 5. Inspection after repairs

It is to be confirmed by means of the magnetic particle inspection that the welded part and its neighbourhood are free from harmful defects.

#### 6. Records

The manufacturer is to make a documentation of the records including sketches of the positions and dimensions of the welded repairs, methods of repairs, details the heat treatment and inspection results for submission to the Surveyor.

#### 7. Preliminary test

The manufacturer shall arrange for the following preliminary tests to be given before repairs by welding; provided however except the cases where change has been made in the material used, welding conditions or welders or where the Society has recognized the necessity specifically, these tests need not be repeated on every occasion.

(1) **Mold cavity weld test**

(A) *Test piece*

Material of same quality with the crank throw.

(B) *Shape of test piece and main point of repairs by welding*

The dimensions of test piece are shown in **Fig 2** Make the cavities as shown there, and then carry out padding welding.

(a) *Sizes cavities*

Proper sizes within the scope permitting free use of the operating electrode.

(b) *Distribution of cavities*

Distribution of cavities and distance of each cavity of the edge of test piece shall be such that these simulate the actual situation in the crank throw to be welded.

(c) *Welding process*

Same as in the actual welding.

(d) *Electrode*

The welding rod same as in the actual welding shall be used.

(e) *Preheating and post heating*

Similar heat treatments to those applied for the crank throw.

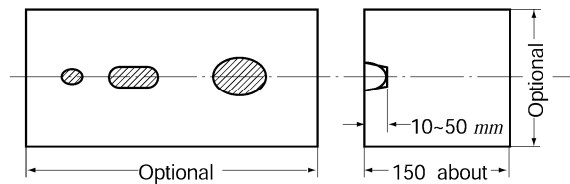


Fig 2 Dimensions and Shape of Test Coupon (Units : mm)

(C) Tests

(a) Macro-structure test

After heat treatment cut down the test piece at the place where the welded part is included, confirming that there is no penetration in the root part of weld nor is any crack.

(b) Hardness test

Check and confirm that there are no changes in the hardness of the weld metal, base metal and the boundary part between them.

(c) Micro-structure

Check and confirm that there are no changes in the structure of the weld metal, base metal and boundary part between them.

(2) Butt weld test

(A) Test coupon

Material of same quality with the crank throw.

(B) Shape of test coupon and main point of repairs by welding

Dimensions and shape of test coupon are shown in Fig 3. The welding conditions and heat treatment are same as in (I) above.

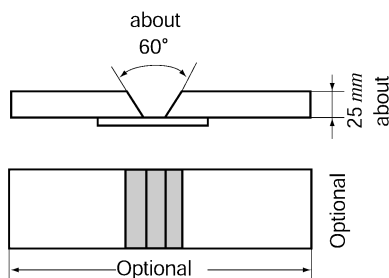


Fig 3 Dimensions and Shape of Test Coupon

	Discard
	Test piece for tensile test
	Test piece for bend test
	Test piece for bend test
	Test piece for tensile test
	Discard

Fig 4 Test Assembly

(C) Test

Each two test pieces are to be prepared for tension test and bending test respectively as shown in Fig 4 from the test coupon described in Fig 3.

(a) Tensile test

Tensile test is to be carried out with the welded metal at the center part of the gauge length. The value obtained is not to be less than the specified minimum value of the base metal. (Test piece dimension = 14 mm  $\phi$   $\times$  70 mm)

(b) Bending test

Place the welded metal on the center part of test piece, bending to 180° with the inside radius of 25 mm, and confirm that no defects have appeared in the welded part and heat affecting part.

(Test piece dimension = 25 mm  $\times$  19 mm  $\times$  any given length)  $\downarrow$

## Annex 2-5 Guidance for non-destructive examination of hull and machinery steel forgings

### 1. Application

- (1) The requirements in this Guidance is intended to give general guidance on the extent, methods and recommended quality levels applicable to the non-destructive examinations (NDE) of steel forgings(hereinafter referred to as "forgings") specified in **Ch 1, 601. 8** and **10** of the Rules.
- (2) For steel forgings(e.g. components for couplings, gears, boilers and pressure vessels) other than those specified in this Guidance, the requirements in this Guidance may apply correspondingly considering their materials, kinds, shapes and stress conditions being subjected.
- (3) The requirements in this Guidance may be also applied to the testing of austenitic stainless steel and ferritic-austenitic (duplex) stainless steel forgings. (2022)
- (4) Forgings should be examined in the final delivery condition. Where intermediate inspections have been performed the manufacturer should provide reports of the results upon the request of the Surveyor. (2022)
- (5) Where a forging is supplied in semi finished condition, the manufacturer shall take into consideration the quality level of final finished machined components.
- (6) NDE personnel requirements and inspection plans are to comply with the requirements specified in **Annex 2-2, 2** and **4 (2), (a)** of this Guidance.
- (7) Where advanced ultrasonic testing methods are applied, e.g. PAUT or TOFD, reference is made to **Annex 2-12** for general approach in adopting and application of these advanced methods. Acceptance levels regarding accept/reject criteria should be as per the applicable requirements in this Guidance. (2022)

### 2. Surface Inspections

#### (1) General

- (A) Surface inspections in this Guidance should be carried out by visual examination and magnetic particle testing or penetrant testing, for the purpose of detecting relevant indications and assessing them against accept/reject criteria stated herein. Personnel engaged in visual examination should have sufficient knowledge and experience, however, may be exempted from formal qualification requirements in this Guidance. (2022)
- (B) The testing procedures, apparatus and conditions of magnetic particle testing and liquid penetrant testing should comply with the recognized national or international standards.
- (C) Other surface inspection methods, e.g. eddy current testing, may be required by the Society as a supplementary method, e.g. for confirming the presence of indications, or for detecting the presence of undocumented weld repairs. This Guidance does not include accept/reject criteria for this purpose and is mentioned here for information only. (2022)

#### (2) Products

- (A) The steel forgings specified in **Pt 2, Ch 1, 601.** should be subjected to a 100 % visual examination of all accessible surfaces by the manufacturer and made available to the Surveyor. For mass produced forgings the extent of examination is to be as deemed appropriate by the Society. (2022)
- (B) It is noted that **Pt 2, Ch 1, 601.** does not include every forged component type that may be subject to Classification(for example, forged slewing rings). In such cases where the particular component or type is not included, either in **Pt 2, Ch 1, 601.** or this Guidance, appropriate national/international standards, or relevant Rules may be applied, to determine the appropriate testing regime and defect acceptance criteria. (2022)
- (C) Austenitic stainless steel and ferritic-austenitic(duplex) stainless steel forgings acceptance criteria details are included in this Guidance for surface and volumetric inspections, however, other acceptance criteria and national or Austenitic international standards may be applied, upon agreement with the Society. (2022)
- (D) Where such standards are used or referenced as a basis for accept and reject criteria, the quality level should provide reasonable equivalence to the allowable criteria stated in the appropriate tables within this Guidance. The quality levels would normally be the highest or most stringent, to provide reasonable equivalence with this Guidance. (2022)
- (E) Surface inspections by magnetic particle and/or penetrant methods generally apply to the following steel forgings:
  - (a) All crankshafts;
  - (b) Propeller shafts, intermediate shafts, thrust shafts and rudder stocks with minimum di-

ameter not less than 100 mm;

(c) Cylinder heads, connecting rods, piston rods and crosshead, as per the engine type and size requirements in **Pt 5** of the Rules. (2022)

(d) Bolts with minimum diameter not less than 50 mm, which are subjected to dynamic stresses such as cylinder cover bolts, coupling bolts for crankshafts, tie rods, crankpin bolts, main bearing bolts and other items as per the engine type and size requirements in **Pt 5** of the Rules. (2022)

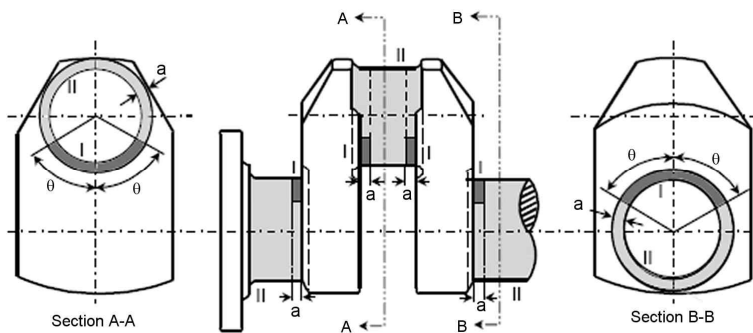
(e) Propeller blade fastening bolts which are subjected to dynamic stresses. (2022)

**(3) Zones for Surface Inspections**

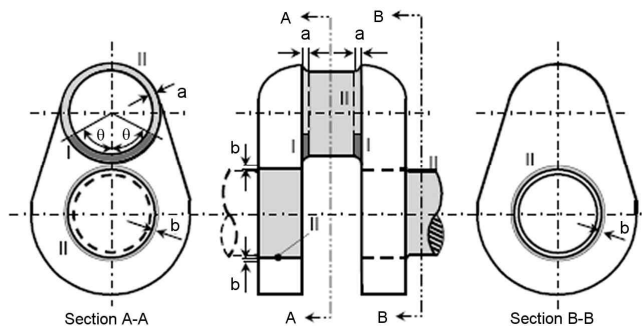
Magnetic particle, or where permitted penetrant testing, should be carried out in zones I, II and III(as applicable) as indicated in **Figs 1 to 4**. (2022)

**(4) Surface Condition**

The surfaces of forgings to be examined should be free from scale, dirt, grease or paint.



(a) Solid crankshaft



(b) Semi built-up crankshaft

Notes)

1. Where the crankpin or journal has oil holes, the circumferential surfaces of the oil holes are to be treated as Zone I. (See the figure in the right.)

2. In the above figures, "θ", "a" and "b" mean:

$\theta = 60^\circ$

$a = 1.5 r$

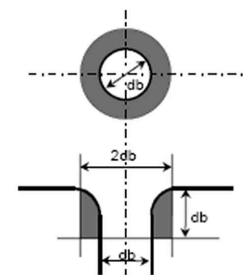
$b = 0.05 d$  (circumferential surfaces of shrinkage fit)

where,

r : fillet radius

d : journal diameter

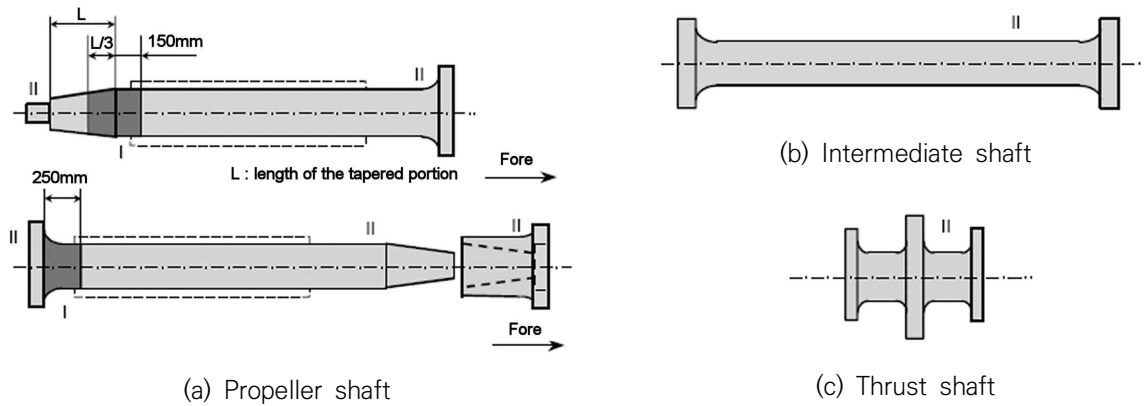
3. Identification of the Zones (Similar in Figs. 1 thru 4):



db : oil hole bore diameter

**Fig 1 Zones for magnetic particle / liquid penetrant testing on crankshafts**





Note) For propeller shaft, intermediate shafts and thrust shafts, all areas with stress raisers such as radial holes, slots and key ways are to be treated as Zone I.

Fig 2 Zones for magnetic particle / liquid penetrant testing on shafts

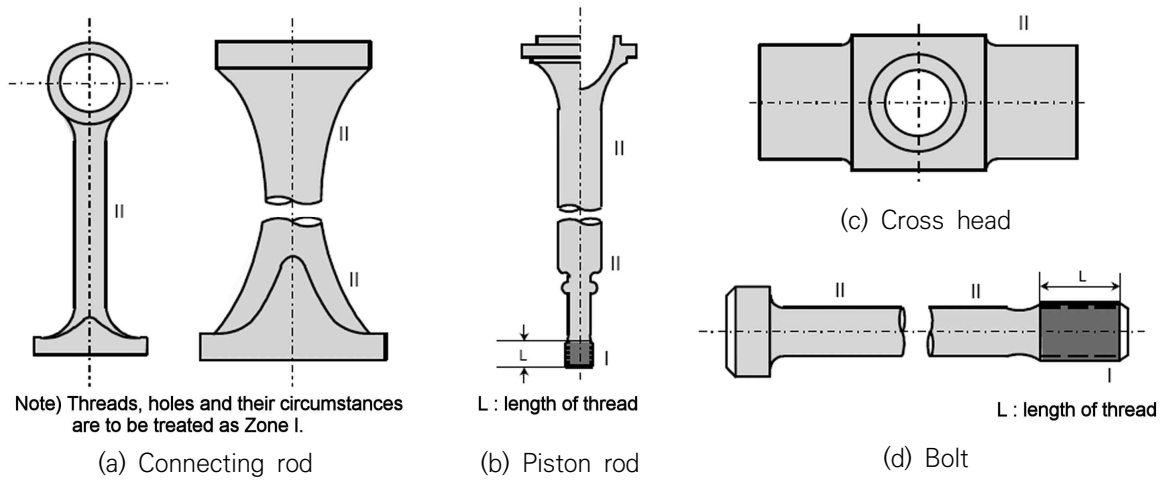


Fig 3 Zones for magnetic particle / liquid penetrant testing on machinery components

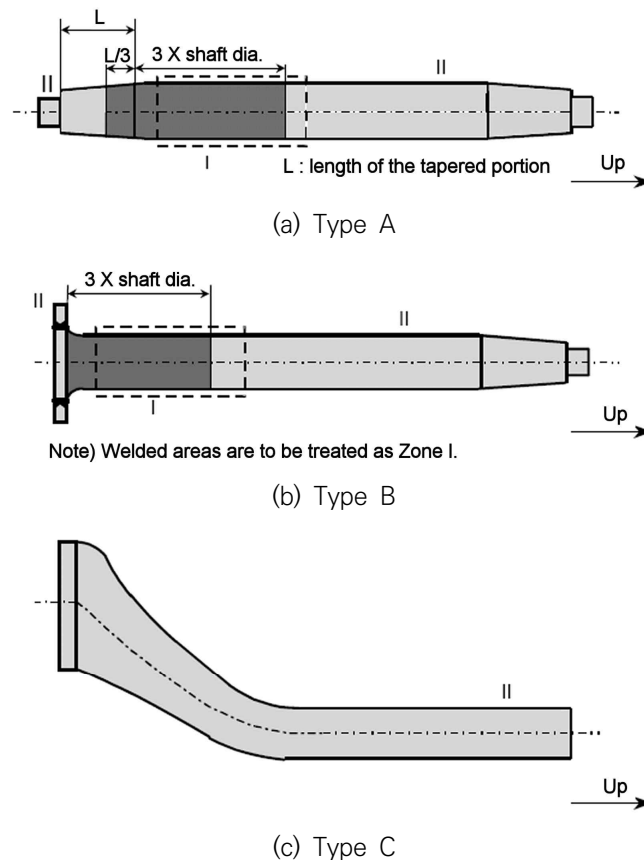


Fig 4 Zones for magnetic particle / liquid penetrant testing on rudder stocks

(5) **Surface Inspection (2022)**

- (A) Where indicated by **Figs 1 to 4**, magnetic particle inspection should be carried out with the following exceptions, when penetrant testing would be permitted :
- austenitic and ferritic-austenitic(duplex) stainless steels;
  - interpretation of open visual or magnetic particle indications,
  - at the instruction of the Surveyor.
- (B) Unless otherwise detailed in the specification, the magnetic particle test should be performed on a forging in the final machined surface condition and final thermally treated condition.
- (C) Unless otherwise agreed, the surface inspection should be carried out in the presence of the Surveyor. The surface inspection should be carried out before the shrink fitting, where applicable.
- (D) For magnetic particle testing, attention should be paid to the contact between the forging and the clamping devices of stationary magnetization benches in order to avoid local over-heating or burning damage in its surface. Prods should not be permitted on finished machined items.
- (E) When indications are detected as a result of the surface inspection, acceptance or rejection is to be decided in accordance with clause (6)

(6) **Acceptance Criteria and Rectification of Defects (2022)**

(A) *Acceptance Criteria Visual Inspection*

- (a) All forgings should be free of cracks, crack-like indications, laps, seams, folds, or other detrimental indications. At the request of the Surveyor, additional magnetic particle, penetrant and ultrasonic testing may be required for a more detailed evaluation of surface irregularities.
- (b) The bores of hollow propeller shafts should be visually examined for imperfections uncovered by the machining operation.

(B) *Acceptance Criteria Magnetic Particle Testing and Liquid Penetrant Testing*

- (a) The following definitions relevant to indications apply:

(i) Linear indication : an indication with a largest dimension three or more times its

- smallest dimension (i.e.  $l \geq 3w$ ).
- (ii) Nonlinear indication : an indication with a largest dimension less than three times its smallest dimension (i.e.  $l < 3w$ ).
  - (iii) Aligned indication :
    - Non-linear indications form an alignment when the distance between indications is less than 2mm and at least three indications are aligned. An alignment of indications is considered to be a unique indication and its length is equal to the overall length of the alignment.
    - Linear indications form an alignment when the distance between two indications is smaller than the length of the longest indication.
  - (iv) Open indication : an indication visible after removal of the magnetic particles or that can be detected by the use of penetrant testing;
  - (v) Non-open indication : an indication that is not visually detectable after removal of the magnetic particles or that cannot be detected by the use of penetrant testing,
  - (vi) Relevant indication : an indication that is caused by a condition or type of discontinuity that requires evaluation. Only indications which have any dimension greater than 1.5 mm shall be considered relevant for the categorization of indications.
- (b) For the purpose of evaluating indications, the surface should be divided into reference areas of 225 cm<sup>2</sup>. The area shall be taken in the most unfavourable location relative to the indication being evaluated.
  - (c) The allowable number and size of indications in the reference area is given in **Table 1** for crankshaft forgings and in **Table 2** for other forgings(including austenitic stainless steel and ferritic-austenitic(duplex) stainless steel forgings), respectively. Cracks are not acceptable. Irrespective of the results of non-destructive examination, the Surveyor may reject the forging if the total number of indications is excessive.
- (C) *Rectification of Defects*
- (a) Defects and unacceptable indications must be rectified as indicated below and detailed in (i) thru (v). Generally it may be permissible to remove shallow indications by light grinding to a maximum depth of 1.5 mm.
    - (i) Defective parts of material may be removed by grinding, or by chipping and grinding. All grooves shall have a bottom radius of approximately three times the groove depth and should be smoothly blended to the surface area with a finish equal to the adjacent surface.
    - (ii) To depress is to flatten or relieve the edges of a non-open indication with a fine pointed abrasive stone with the restriction that the depth beneath the original surface shall be 0.08 mm minimum to 0.25 mm maximum and that the depressions be blended into the bearing surface. A depressed area is not considered a groove and is made only to prevent galling of bearings.
    - (iii) Non-open indications evaluated as segregation need not be rectified.
    - (iv) Complete removal of the defect should be proved by magnetic particle testing or penetrant testing, as appropriate.
    - (v) Repair welding should not be permitted for crankshafts or rotating items subjected to torsional fatigue(such as propeller shafts). Repair welding of other forgings should be subject to prior approval of the Society.
    - (vi) Grinding is not permitted in way of finished machined threads.
  - (b) *Zone I in crankshaft forgings*  
Neither indications nor repair are permitted in this zone.
  - (c) *Zone II in crankshaft forgings*
    - (i) Indications must be removed by grinding to a depth no greater than 1.5 mm.
    - (ii) Indications detected in the journal bearing surfaces must be removed by grinding to a depth no greater than 3.0 mm. The total ground area shall be less than 1 % of the total bearing surface area concerned.
    - (iii) Non-open indications, except those evaluated as segregation, shall be depressed but need not be removed.

**Table 1 Crankshaft forgings ; Allowable number and size of surface indications in a reference area of 225 cm<sup>2</sup> (2022)**

Inspection Zone	Max. number of indications	Type of indication	Max. number for each type	Max. dimension (mm)
I (critical fillet area)	0	Linear	0	-
		Nonlinear	0	-
		Aligned	0	-
II (important fillet area)	3	Linear	0	-
		Nonlinear	3	3.0
		Aligned	0	-
III (journal surfaces)	3	Linear	0	-
		Nonlinear	3	5.0
		Aligned	0	-

**Table 2 Steel forgings excluding crankshaft forgings ; Allowable number and size of surface indications in a reference area of 225 cm<sup>2</sup> (2022)**

Inspection Zone	Max. number of indications	Type of indication	Max. number for each type	Max. dimension (mm)
I	3	Linear	0 <sup>(1)</sup>	-
		Nonlinear	3	3.0
		Aligned	0 <sup>(1)</sup>	-
II	10	Linear	3 <sup>(1)</sup>	3.0
		Nonlinear	7	5.0
		Aligned	3 <sup>(1)</sup>	3.0

Note:  
 (1) Linear or aligned indications are not permitted on bolts, which receive a direct fluctuating load, e.g. main bearing bolts, connecting rod bolts, crosshead bearing bolts, cylinder cover bolts.

(d) *Zone I in other forgings*

Indications must be removed by grinding to a depth no greater than 1.5 mm.

(e) *Zone II in other forgings*

Indications must be removed by grinding to a depth no greater than 2 % of the diameter or 4.0 mm, whichever is smaller.

(f) *Zones other than I and II in all forgings*

Defects detected by visual inspection must be removed by grinding to a depth no greater than 5 % of the diameter or 10mm, whichever is smaller. The total ground area shall be less than 2 % of the forging surface area.

**(7) Record (2022)**

Test results of surface inspections should be recorded at least with the following items:

- (a) Date of testing;
- (b) Names, signature(s) and qualification level of inspection personnel;
- (c) Testing method and testing details, including procedure number;
  - for liquid penetrant testing : the penetrant system used and viewing conditions(as appropriate to the penetrant technique and media used)
  - for magnetic particle testing : method of magnetizing, test media, magnetic field strength, magnetic flux indicators(where appropriate), and viewing conditions (as appropriate to the magnetizing technique and media used)
- (d) Type of product;
- (e) Product number and unique identification;
- (f) Grade of steel;
- (g) Heat treatment;
- (h) Stage of testing;
- (i) Position (zone) of testing;
- (j) Surface condition;
- (k) Test standards used, including reference to the appropriate tables for acceptance purposes;
- (l) Testing condition;
- (m) Results, including documentation regarding the repair and testing history(as appropriate);
- (n) Statement of acceptance/non acceptance,
- (o) Details of weld repair including sketch(where applicable);

**3. Ultrasonic testing****(1) General (2022)**

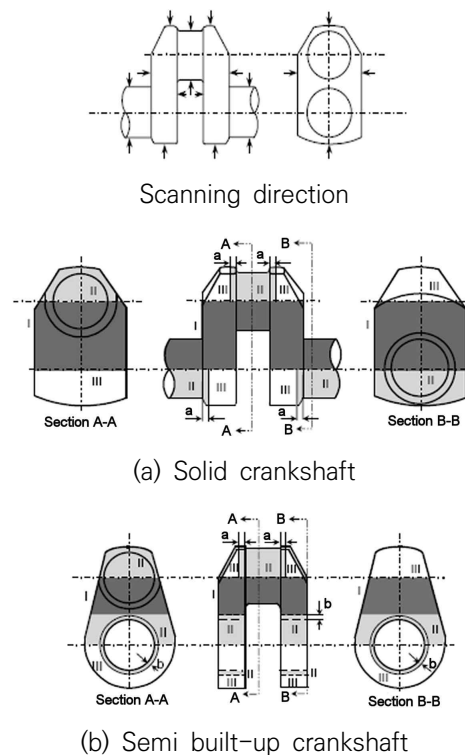
- (A) Volumetric inspection in this Guidance should be carried out by ultrasonic testing using the contact method with straight beam and/or angle beam technique. Advanced UT methods (such as PAUT or TOFD) should meet the general requirements of **Annex 2-12**.
- (B) The testing procedures, apparatus and conditions of ultrasonic testing should comply with recognized national or international standards. Generally, the methods of setting test sensitivity and testing evaluation utilise the DAC(distance amplitude correction) or DGS(distance-gain size) methods. The applied methodology should use 2 to 4 MHz straight beam(or normal) probes and/or angle beam probes. For near surface testing(up to a depth of 25 mm) twin crystal 0° probe should be used, plus a 0° probe (usually single crystal beyond a depth of 25 mm) for the remaining volume. The appropriate acceptance criteria tables should be used, depending on the sensitivity method selected.
- (C) Fillet radii should be examined using 45°, 60° or 70° probes, primarily to determine the presence of any cracks within the radiused areas, and as an additional scan to confirm any indications that may have been detected with 0° probe(s) within this area.
- (D) For fabricated forgings and weld repairs, weld testing should be carried out to the appropriate standard, and the acceptance tables contained herein should not be used as a basis for acceptance criteria of welds.
- (E) Construction of DAC curves for normal probes should be performed using reference blocks containing suitably sized Flat Bottom Holes (FBH) spaced over the inspection thickness. Reference blocks should be manufactured from similar material, with similar surface condition to that being inspected. Where necessary, allowances should be made for attenuation losses by performing a transfer correction and adjusting the DAC curve as required. The applied transfer correction(measured in decibels(dB)) should become the new reference sensitivity, to which indications are evaluated against, according to the appropriate table contained herein.

**(2) Products (2022)**

- (A) Volumetric inspections by ultrasonic testing generally apply to the following steel forgings :
  - (a) All crankshafts
  - (b) Propeller shafts, intermediate shafts, thrust shafts and rudder stocks with minimum diameter not less than 200 mm,
  - (c) Cylinder heads, connecting rods, piston rods, crosshead, coupling bolts and studs as per the engine type and size requirements in **Pt 5** of the Rules.
- (B) It is noted that **Pt 2, Ch 1, 601.** of the Rules does not include every forged component type that may be subject to Classification(for example, forged slewing rings). In such cases where the particular component or type is not included, either in **Pt 2, Ch 1, 601.** of the Rules or this Recommendation, appropriate national/international standards, or Rules may be applied,

to determine the appropriate testing regime and defect acceptance criteria.

- (C) Where such standards are used or referenced as a basis for accept and reject criteria, the quality level should provide reasonable equivalence to the allowable criteria stated in the appropriate tables within this Guidance. The quality levels would normally be the highest or most stringent, to provide reasonable equivalence with this Guidance.
- (D) Ultrasonic acceptance criteria detailed in **Tables 3 to 6** are intended for C, C-Mn, and alloy steel forgings, and do not apply to austenitic stainless steel or ferritic-austenitic(duplex) stainless steel forgings. Examples of standards for acceptance criteria for stainless steel or duplex stainless steel forgings are detailed below, and quality levels should be agreed with the Society. Other national or international standards may be used, as agreed with the Society.
- (a) **ASTM A745/A745M-20**  
 (b) **EN 10228-4:2016**
- (3) **Zones for ultrasonic testing**
- (A) Ultrasonic testing should be carried out in the zones I to III as indicated in Figs 5 to 8. Areas may be upgraded to a higher zone at the discretion of the Surveyors.

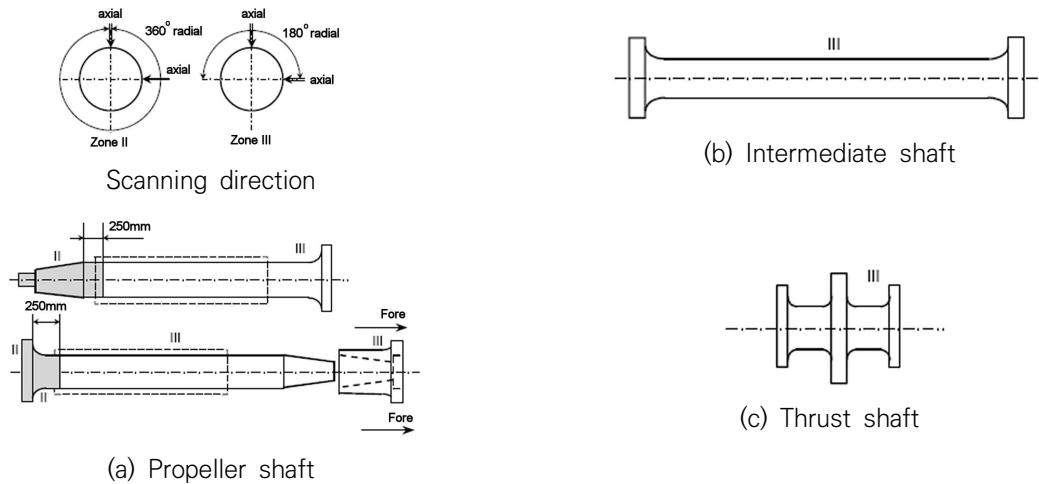


Note)

- In the above figures, "a" and "b" mean:
  - a = 0.1d or 25mm, whichever greater
  - b = 0.05d or 25mm, whichever greater (circumstances of shrinkage fit)
 where,
  - d : pin or journal diameter
- Core areas of crank pins and/or journals within a radius of 0.25d between the webs may generally be coordinated to Zone II.
- Identification of the Zones (Similar in Figs. 5 thru 8.):

	: Zone I
	: Zone II
	: Zone III

Fig 5 Zones for ultrasonic testing on crankshafts



Notes)

1. For hollow shafts, 360° radial scanning applies to Zone III.
2. Circumferences of the bolt holes in the flanges are to be treated as Zone II.

Fig 6 Zones for ultrasonic testing on shafts

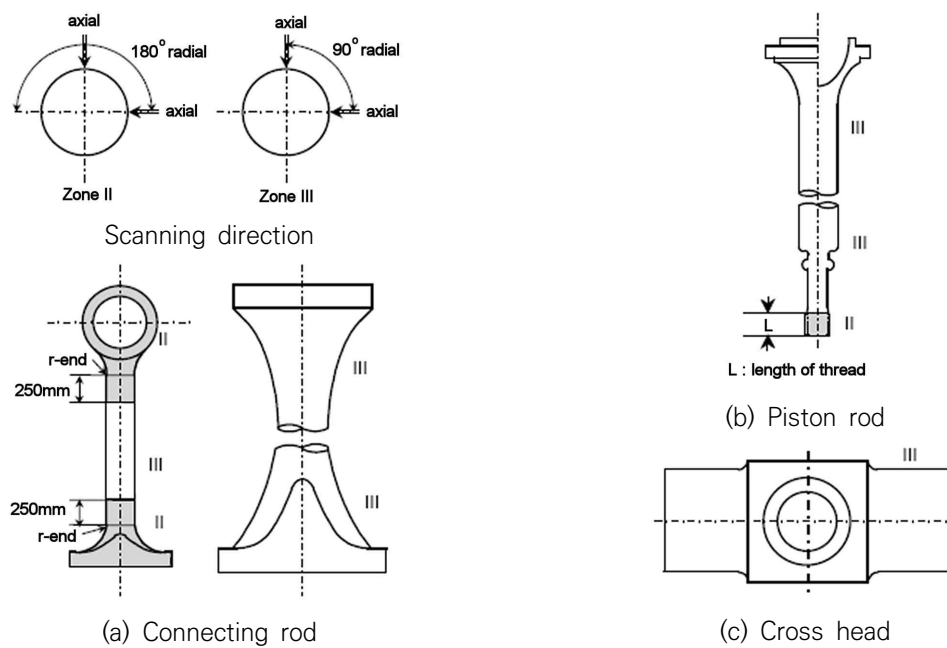


Fig 7 Zones for ultrasonic testing on machinery components

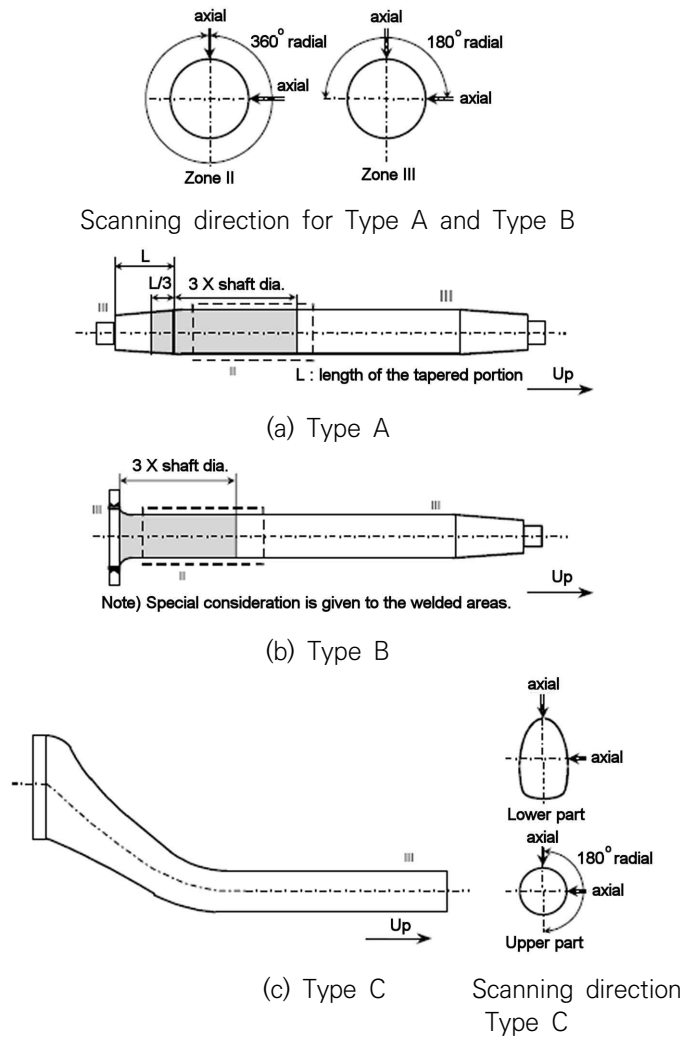


Fig 8 Zones for ultrasonic testing on rudder stocks

(4) **Surface Condition**

- (A) The surfaces of forgings to be examined should be such that adequate coupling can be established between the probe and the forging and that excessive wear of the probe should be avoided. The surfaces are to be free from scale, dirt, grease or paint.
- (B) The ultrasonic testing should be carried out after the steel forgings have been machined to a condition suitable for this type of testing and after the final heat treatment, but prior to the drilling of the oil bores, prior to surface hardening and the machining of bolt threads. Black (or 'as forged') forgings should be inspected after removal of the oxide scale by either flame descaling or shot blasting methods. (2022)

(5) **Acceptance Criteria**

Acceptance criteria of volumetric inspection by ultrasonic testing are shown in **Table 3** and **6**.



Table 3 Ultrasonic Acceptance Criteria for Crankshafts: DGS Method-Normal Probes (2022)

Type of Forging	Zone	Allowable disc shape according to DGS <sup>(1)</sup>	Allowable length of indication <sup>(2)</sup>	Allowable distance between two indications <sup>(3)</sup>
Crank shaft	I	$d \leq 1.0 \text{ mm}^{(4)}$	Not applicable <sup>(5)</sup>	Not applicable
	II	$d \leq 2.0 \text{ mm}$	$\leq 10 \text{ mm}$	$\geq 20 \text{ mm}$
	III	$d \leq 4.0 \text{ mm}$	$\leq 15 \text{ mm}$	$\geq 20 \text{ mm}$

Notes :

- (1) DGS : Distance Gain Size evaluation system
- (2) The transference distance of the probe in the range where the echo height exceeds 50% of DGS line is taken as the length of indication.
- (3) In case of accumulations of two or more isolated indications which are subjected to registration the minimum distance between two neighbouring indications should be at least the length of the larger indication. This also applies to the distance in axial direction as well as to the distance in depth. Isolated indications with less distances should be determined as one single indication.
- (4) For zone 1 testing, probe selection should take into account the limits of probe beam-path length and depth of beam penetration and should normally be carried out with a minimum probe frequency of 4 MHz.
- (5) For zone 1, indications with an echo height greater than a 1.0 mm disc shaped reflector are not acceptable. Indications with an echo height of less than or equal to 1.0 mm are acceptable if they are deemed as point reflectors and have no measurable length.

Table 4 Ultrasonic Acceptance Criteria for Crankshafts: DAC Method-Normal Probes (2022)

Type of Forging	Zone	DAC reference level, based on 3.0 mm FBH <sup>(1)(2)(3)</sup>	Allowable length of indication	Allowable distance between two indications <sup>(5)</sup>
Crank shaft	I	3.0 mm DAC - 19 dB	Not applicable <sup>(4)</sup>	Not applicable
	II	3.0 mm DAC - 7 dB	$\leq 10.0 \text{ mm}$	$\geq 20 \text{ mm}$
	III	3.0 mm DAC + 5 dB	$\leq 15.0 \text{ mm}$	$\geq 20 \text{ mm}$

Notes :

- (1) The requirement of a 3mm FBH is to standardise the DAC reference blocks for clarity and consistency. The dB value for the FBH/DAC setting is equivalent to the disc shaped reflector stated in **Table 3**, corresponding to the applicable zone.
- (2) Other size FBH's may be used for the DAC method (and the dB value adjusted accordingly to provide equivalence with the stated FBH/disc shaped reflector). Where other size FBH's are used, the ultrasonic procedure should state the equivalence using an appropriate calculation formula.
- (3) For zone 1 testing, probe selection should take into account the limits of probe beam-path length and depth of beam penetration and should normally be carried out with a minimum probe frequency of 4 MHz.
- (4) For zone 1, indications with an echo height greater than the DAC reference level are not acceptable. Indications with an echo height of less than the DAC reference level are acceptable if they are deemed as point reflectors and have no measurable length.
- (5) In case of accumulations of two or more isolated indications which are subject to registration the minimum distance between two neighbouring indications be at least the length of the larger indication. This also applies to the distance in axial directions as well as to the distance in depth. Isolated indications with less distances should be determined as one single indication.

**Table 5 Ultrasonic Acceptance Criteria for Shafts and Machinery Components: DGS Method-Normal Probes (2022)**

Type of Forging	Zone	Allowable disc shape according to DGS <sup>(1)(2)</sup>	Allowable length of indication <sup>(3)</sup>	Allowable distance between two indications <sup>(4)</sup>
Propeller shaft, intermediate shaft	II	outer: $d \leq 2$ mm inner: $d \leq 4$ mm	$\leq 10$ mm $\leq 15$ mm	$\geq 20$ mm $\geq 20$ mm
Thrust shaft, Rudder stock	III	outer: $d \leq 3$ mm inner: $d \leq 6$ mm	$\leq 10$ mm $\leq 15$ mm	$\geq 20$ mm $\geq 20$ mm
Connecting rod,	II	$d \leq 2.0$ mm	$\leq 10$ mm	$\geq 20$ mm
Piston rod, Crosshead	III	$d \leq 4.0$ mm	$\leq 10$ mm	$\geq 20$ mm

Notes :

(1) DGS : Distance Gain Size evaluation system  
(2) Outer part means the part beyond one third of the shaft radius from the centre, the inner part means the remaining core area.  
(3) The transference distance of the probe in the range where the echo height exceeds 50% of DGS line is taken as the length of indication.  
(4) In case of accumulations of two or more isolated indications which are subjected to registration the minimum distance between two neighbouring indications must be at least the length of the larger indication. Isolated indications with less distances should be determined as one single indication.

**Table 6 Ultrasonic Acceptance Criteria for Shafts and Machinery Components: DAC Method-Normal Probes (2022)**

Type of Forging	Zone	DAC reference level, based on 3.0 mm FBH <sup>(1)(2)</sup>	Allowable length of indication	Allowable distance between two indications <sup>(3)</sup>
Propeller shaft, intermediate shaft,	II	Outer : DAC - 7 dB Inner : DAC + 5 dB	$\leq 10.0$ mm $\leq 15.0$ mm	$\geq 20$ mm $\geq 20$ mm
Thrust shaft, Rudder stock	III	Outer : +0 DAC Inner : DAC + 12 dB	$\leq 10.0$ mm $\leq 15.0$ mm	$\geq 20$ mm $\geq 20$ mm
Connecting rod,	II	DAC - 7 dB	$\leq 10.0$ mm	$\geq 20$ mm
Piston rod, Crosshead	III	DAC + 5 dB	$\leq 10.0$ mm	$\geq 20$ mm

Notes :

(1) The requirement of a 3 mm FBH is to standardise the DAC reference blocks for clarity and consistency. The dB value for the FBH/DAC setting is equivalent to the disc shaped reflector stated in **Table 3**, corresponding to the applicable zone.  
(2) Other size FBH's may be used for the DAC method (and the dB value adjusted accordingly to provide equivalence with the stated FBH/disc shaped reflector). Where other size FBH's are used, the ultrasonic procedure should state the equivalence using an appropriate calculation formula.  
(3) In case of accumulations of two or more isolated indications which are subjected to registration the minimum distance between two neighbouring indications must be at least the length of the larger indication. This also applies to the distance in axial directions as well as to the distance in depth. Isolated indications with less distances should be determined as one single indication.

**(6) Reporting (2022)**

Test results of volumetric inspection should be recorded at least with the following items:

- (a) Date of testing;
- (b) Name(s), signature(s) and qualification level of inspection personnel;
- (c) Testing method including procedure number, and details of the following items:
  - Equipment used(instrument, probes [and any adaptations to probes for curved surfaces], calibration and reference blocks)
  - Technique(s) used to set test sensitivity(including sensitivity method, specific reference blocks, reflector size, transfer correction)
  - Maximum scanning rate(mm/s)
  - Details of any testing restrictions
- (d) Type of product;
- (e) Product number and unique identification;
- (f) Grade of steel;
- (g) Heat treatment;
- (h) Stage of testing;
- (i) Position (zone) of testing;
- (j) Surface condition;
- (k) Test standards used including reference to the appropriate tables for acceptance purposes;
- (l) Testing condition;
- (m) Results including documentation regarding the repair and testing history(as appropriate);
- (n) Statement of acceptance/non acceptance;
- (o) Details of weld repair including sketch(where applicable). ⚡

## Annex 2-6 Guidance for liquid penetrant inspection and repair of defects of copper alloy propeller castings

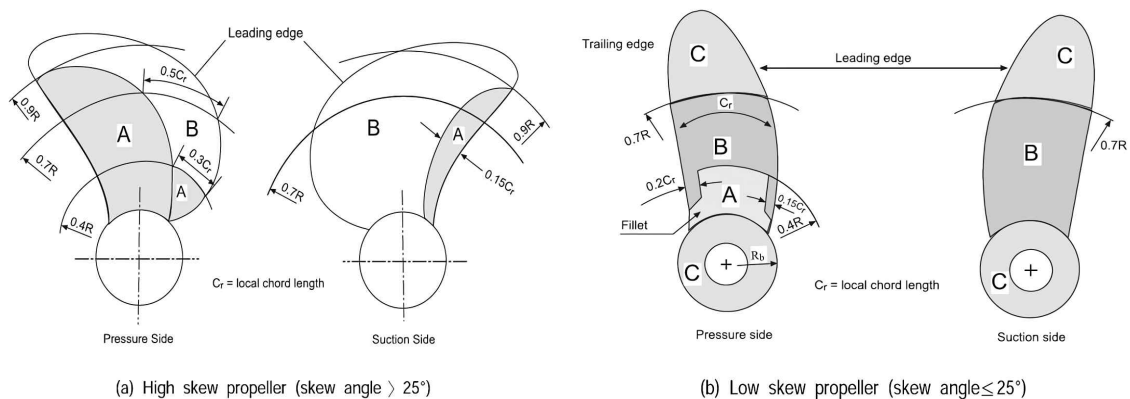
### 1. Applications

This requirement applies to the liquid penetrant inspection and repair of defects of propeller castings. Repair method for propeller differing from those specified in this Guidance are to comply with the discretion of the Society.

### 2. The liquid penetrant inspection

#### (1) Area of test (Severity zones)

- In order to relate the degree of inspection to the criticality of defects in propeller blades and to help reduce the risk of failure by fatigue cracking after repair, propeller blades are divided into the three severity zones designated A, B and C as shown in **Fig 1** and **Fig 2**
- The severity zones "A" are to be subjected to a dye penetrant inspection in the presence of the Surveyor. In zones "B" and "C" the dye penetrant inspection is to be performed by the manufacturer and may be witnessed by the Surveyor upon his request.
- If repairs have been made either by grinding, straightening or by welding the repaired areas are additionally to be subjected to the dye penetrant inspection independent of their location and/or severity zone.

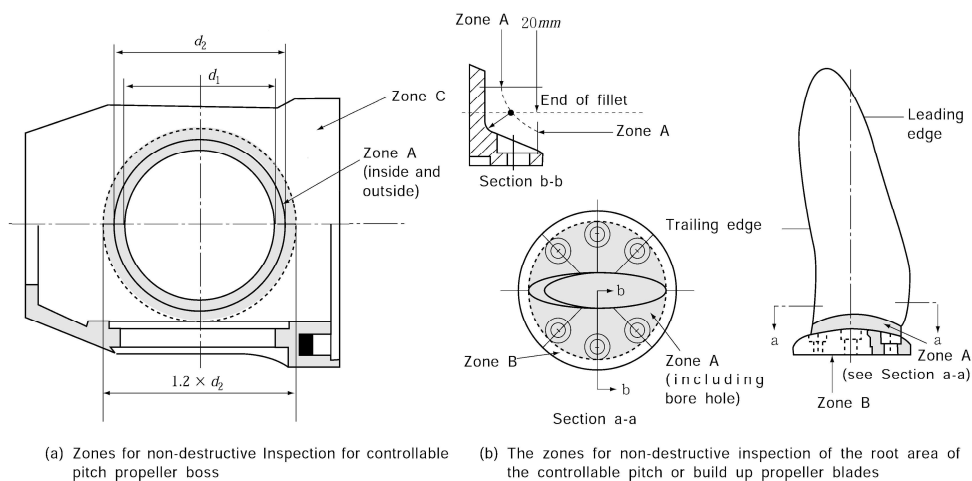


\* The definition of skew angle comply with the requirements in the Pt 5, Ch 3, 303. of the Guidances

(Notes)

- $R$  : The radius of the propeller
- The boss area of an integrally cast propeller is regarded as Zone C.
- Where stress distribution on propeller blade surface is estimated in detail, the non-destructive inspection zones different from those shown in this figure may be applied subject to this Society's approval.

Fig 1 Zones for Non-destructive Inspection of Propeller Castings



**Fig 2 Zones for Non-destructive Inspection on the Root Area of the Controllable Pitch or Build up Propeller Blades and Controllable Pitch Propeller Boss**

**(2) Methods of testing**

- (a) Liquid penetrant testing procedure is to be submitted to the Society and is to be in accordance with **ISO 3452-1:2013** or a recognized standard. The acceptance criteria are specified in (4). (2021)
- (b) Where indications of defects appear, the type of defects and the size of the indications are to be recorded in detail. These records are to be presented to the Surveyor. For reference, the true size of the defects are also to be confirmed.

**(3) Definitions of liquid penetrant indications (refer to Fig 3) (2021)**

- (A) Indication : In the liquid penetrant testing an indication is the presence of detectable bleed-out of the penetrant liquid from the material discontinuities appearing at least 10 minutes after the developer has been applied.
- (B) Relevant indication: Only indications which have any dimension greater than 1.5mm shall be considered relevant for the categorization of indications.
- (C) Non-linear indication: an indication with a largest dimension less than three times its smallest dimension (i.e.  $l < 3w$ ).
- (D) Linear indication: an indication with a largest dimension three or more times its smallest dimension (i.e.  $l \geq 3w$ ).
- (E) Aligned indications
- (a) Non-linear indications form an alignment when the distance between indications is less than 2 mm and at least three indications are aligned. An alignment of indications is considered to be a unique indication and its length is equal to the overall length of the alignment.
- (b) Linear indications form an alignment when the distance between two indications is smaller than the length of the longest indication.

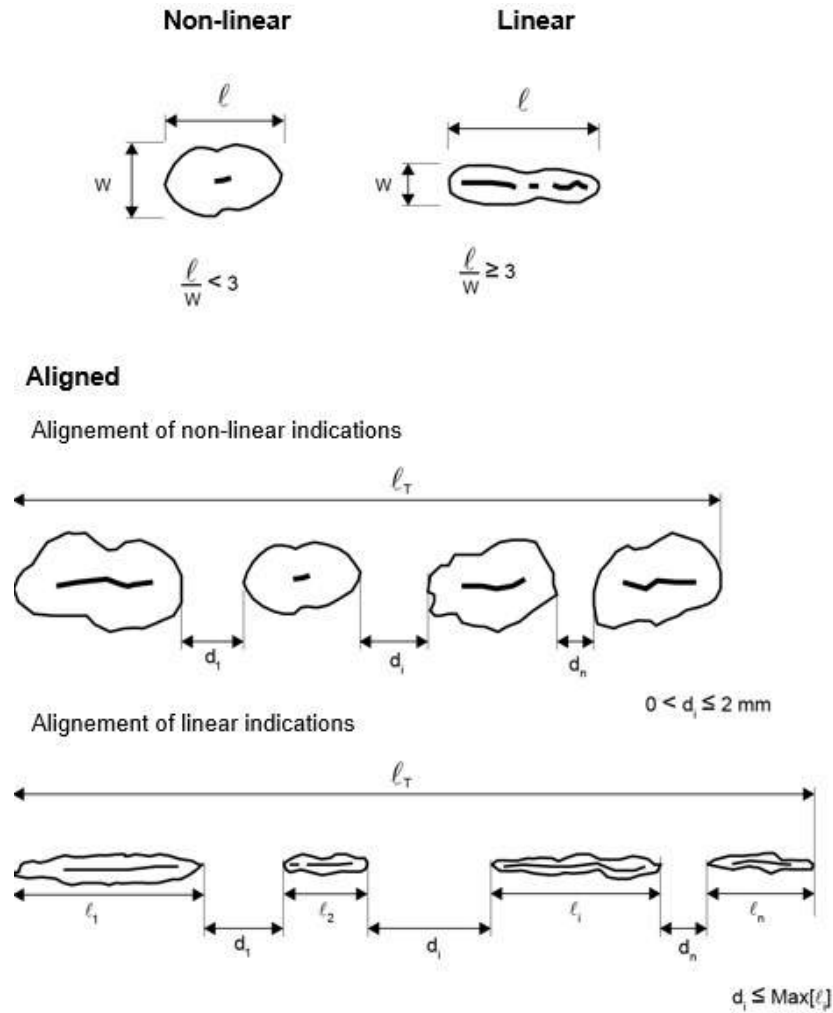


Fig 3 Shape of indications (2021)

**(4) Acceptance criteria**

- (A) Where cracks or other defects which do not meet the acceptance criteria given in **Table 1** are detected by the penetrant test, the defects are to be repaired in accordance with the requirements in **3.**

Table 1 Acceptance Criteria (2021)

Area of test	Type of Indication (excluding crack)	Acceptance Criteria		
		Max. total number of indications(I)	Indications of same type	
			Max. number of each type(II)	Max. size for each indication(III) (mm)
Zone A	Non-linear	7	5	4
	Linear		2	3
	Aligned		2	3
Zone B	Non-linear	14	10	6
	Linear		4	6
	Aligned		4	6
Zone C	Non-linear	20	14	8
	Linear		6	6
	Aligned		6	6

(Notes)

(1) The indications are to be repaired when they do not meet one or more criteria of (I) through (III) in this table.

(2) The counting of the number of indications is to be conducted at the most unfavourable location relative to the indication being evaluated. The area of a reference zone is to be 100cm<sup>2</sup>. Each reference area may be square or rectangular with the major dimension not exceeding 250 mm.

(3) Singular non-linear indications less than 2 mm for zone A and less than 3 mm for other zones are not considered relevant.

(4) Where only non-linear indications were detected, all indications(I) are to be repaired for the judgement.

- (B) Areas which are prepared for welding are independent of their location always to be assessed according to zone A. The same applies to the welded areas after being finished machined and/or grinded.
- (C) Indications exceeding the acceptance standard of **Table 1**, cracks, shrinkage cavities, sand, slag and other non-metallic inclusions, blow holes and other discontinuities which may impair the safe service of the propeller are defined as defects and must be repaired in accordance with the requirements specified in **3** below.

### 3. Repair of defects

#### (1) Repair procedures

- (A) In general, the repairs are to be carried out by mechanical means, e. g. by grinding, chipping or milling. After milling or chipping, grinding is to be applied for such defects.
- (B) The contour of the ground depression is as smooth as possible in order to avoid stress concentrations or to minimize cavitation corrosion.
- (C) Complete elimination of the defective material is to be verified by liquid penetrant testing. (2021)

#### (2) Repair of defects in zone A

- (a) In zone A of **Fig 1** and **Fig 2**, repair welding will generally not be allowed unless specially approved by the Society.
- (b) Grinding may be carried out to an extent which maintains the blade thickness of the approved drawing.
- (c) The possible repair of defects which are deeper than those referred to above is to be considered by the Society.
- (d) In some cases the propeller designer may submit technical documentation to propose a modified zone A based on detailed hydrodynamic load and stress analysis for consideration

by the Society. (2021)

(3) **Repair of defects in zone B**

- (a) In case the depth of defects in zone B of **Fig 1** and **Fig 2**, is not deeper than  $\text{dB}(\text{dB}=\text{t}/40 \text{ mm, t}=\text{Min. local thickness in mm according to the Rules})$  or 2 mm, whichever is greater, those defects may be removed by grinding in accordance with the previous **3. (1)**. (2021)
- (b) For defects that are deeper than those allowable in previous **3. (2) (b)**, upon the approval of the Society, repair welding is possible in accordance with Para 4. (2021)
- (c) Where the propellers in zone B in accordance with the requirements specified in previous (b) are repaired by welding, the limits of the repair welding are to be as shown in **Table 2**.

**Table 2 Limits of Repair Welding** <sup>(2)(3)</sup>

	Pressure side	Suction side
Each area of repair welding <sup>(1)</sup>	75 cm <sup>2</sup> or 0.006 S whichever is larger	150 cm <sup>2</sup> or 0.01 S whichever is larger
Total area of repair welding	200 cm <sup>2</sup> or 0.02 S whichever is larger	
Depth of welding(cm)	0.1 t basically	0.15t basically
Notes:		
(1) Welding of areas less than 5 cm <sup>2</sup> is to be avoided.		
(2) $S = \frac{\pi D^2 \cdot B}{4n}$ (cm <sup>2</sup> )		
D = Diameter of the propeller (cm)		
n = Number of propeller blade		
B = Developed area ratio		
(3) t is the thickness of the blade at the portion of repair welding.(cm)		

(4) **Repair of defects in zone C**

In zone C of **Fig 1** and **Fig 2**, repair welds are generally permitted.

**4. Repair Welding**

Repair welding which permitted in accordance with the requirements in **3 (3)** and **(4)** above is to comply with the following;

(1) **General**

- (a) Before welding is started, manufacturer shall submit to the Society a detailed welding procedure specification covering the weld preparation, welding parameters, filler metals, preheating and post weld heat treatment and inspection procedures. (2021)
- (b) All weld repairs are to be carried out in accordance with qualified procedures, and, by welders who are qualified to a recognized standard. Welding Procedure Qualification Tests are to be carried out in accordance with (5) and witnessed by the Surveyor. (2021)
- (c) All welding work is to be carried out preferably in the shop free from draughts and influence of the weather.

(2) **Welder**

The welders are to have qualifications deemed appropriate by the Society.

(3) **Edge preparation**

- (a) Defects to be repaired by welding are to be ground to sound material according to the requirements as given under para **3 (1)**. The resulting ground areas are to be examined in the presence of the Surveyor by liquid penetrant testing in order to verify the complete elimination of defective material. (2021)
- (b) The welding grooves are to be prepared in such a manner which will allow a good fusion of the groove bottom. (2021)
- (c) The edge preparation for repair welding after removing the defects is to be as shown in **Fig 3** and **4**.



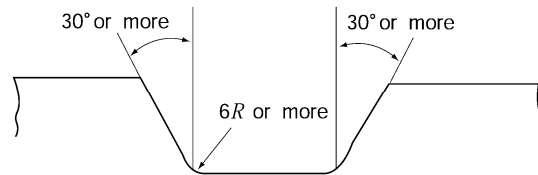


Fig 3 Edge Preparation after Removing Defects

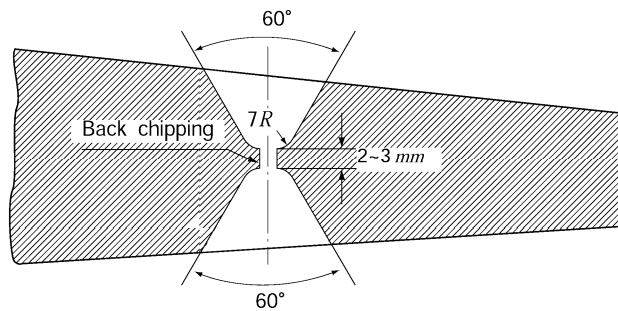


Fig 4 Edge Preparation for Repair Welding of Blade Edge

**(4) Welding repair procedure**

- (a) Metal arc welding is to be used for all types of welding repair on cast copper alloy propellers. (2021)
- (b) Arc welding with coated electrodes and gas-shielded metal arc process (*GMAW*) are generally to be applied. Argon-shielded tungsten welding (*GTAW*) should be used with care due to the higher specific heat input of this process.
- (c) Recommended filler metals, pre-heating and stress relieving temperatures are listed in **Table 3**. However, the welding consumables are to be approved by the approval tests for welding procedure specified in (5).
- (d) All propeller alloys are generally to be welded in down-hand (flat) position. Where this cannot be done, gas-shielded metal arc welding should be carried out.
- (e) The section to be welded is to be clean and dry. Flux-coated electrodes are to be dried before welding according to the maker's instructions.
- (f) Slag, undercuts and other defects are to be removed before depositing the next run.
- (g) To minimize distortion and the risk of cracking, interpass temperatures are to be kept low. This is especially the case with *CU 3* alloys.

**Table 3 Recommended filler metals and heat treatments**

Alloy type	Filler metal	Preheat temperature (°C)	Interpass temperature (°C)	Stress relief temperature (°C)
<i>CU 1</i>	<i>Al</i> -bronze <sup>(1)</sup> <i>Mn</i> -bronze	150 min	300 max	350~500
<i>CU 2</i>	<i>Al</i> -bronze <i>Ni-Mn</i> -bronze	150 min	300 max	350~550
<i>CU 3</i>	<i>Al</i> -bronze <i>Ni-Al</i> -bronze <sup>(2)</sup> <i>Mn-Al</i> -bronze	50 min	250 max	450~550
<i>CU 4</i>	<i>Mn-Al</i> -bronze	100 min	300 max	450~600

Notes:

- (1) *Ni-Al*-bronze and *Mn-Al*-bronze are acceptable.
- (2) Stress relieving not required, if filler metal *Ni-Al*-bronze is used.

- (h) With the exception of alloy *CU 3* (*Ni-Al-bronze*) all weld repairs are to be stress relief heat treated, in order to avoid stress corrosion cracking. However, stress relief heat treatment of alloy *CU 3* propeller castings may be required after major repairs in zone B (and specially approved welding in Zone A) or if a welding consumable susceptible to stress corrosion cracking is used. In such cases the propeller is to be either stress relief heat treated in the temperature 450 to 500°C or annealed in the temperature range 650–800°C, depending on the extent of repair, c. f. **Table 3**.
- (i) The soaking times for stress relief heat treatment of copper alloy propellers should be in accordance with **Table 4**. The heating and cooling is to be carried out slowly under controlled conditions. The cooling rate after any stress relieving heat treatment shall not exceed 50°C/h until the temperature of 200°C is reached.

**Table 4 Soaking times for stress relief heat treatment of copper alloy propellers**

Stress relief Temp.	Alloy grade <i>CU1</i> and <i>CU2</i>		Alloy grade <i>CU3</i> and <i>CU4</i>	
	Hours per 25 mm thickness	Max. recommended total time hours	Hours per 25 mm thickness	Max. recommended total time hours
350	5	15	–	–
400	1	5	–	–
450	1/2	2	5	15
500	1/4	1	1	5
550	1/4	1/2	1/2	2
600	–	–	1/4	1

**(5) Welding procedure qualification test**

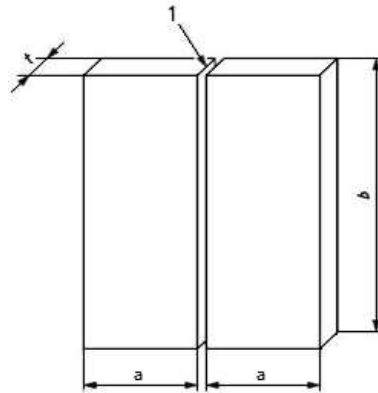
The manufacturer of propellers intending to carry out repair welding in zone B and zone C is to pass the welding procedure qualification test as shown below. The qualification test is also to be in accordance with the requirements specified in **Pt 2, Ch 2, Sec 4** of the Rules, in addition to the following requirements:

**(A) General (2021)**

- (a) For the welding procedure approval the welding procedure qualification tests are to be carried out with satisfactory results. The qualification tests are to be carried out with the same welding process, filler metal, preheating and stress-relieving treatment as those intended applied by the actual repair work. Welding procedure specification (WPS) is to refer to the test results achieved during welding procedure qualification testing.
- (b) Welding procedures qualified at a manufacturer are valid for welding in workshops under the same technical and quality management.

**(B) Tests for butt welding (2021)****(a) Test assembly**

- (i) The test assembly, consisting of cast samples, is to be of a size sufficient to ensure a reasonable heat distribution and according to **Fig 5** with the minimum dimensions.
- (ii) A test sample of minimum 30 mm thickness is to be used.
- (iii) Preparation and welding of test pieces are to be carried out in accordance with the general condition of repair welding work which it represents.
- (iv) Welding of the test assemblies and testing of test specimens are to be witnessed by the Surveyor.



(Notes)

- 1 : Joint preparation and fit-up as detailed in the preliminary welding procedure specification
- a : minimum value 150 mm
- b : minimum value 300 mm
- t : material thickness

**Fig 5 Test piece for welding repair procedure**

(b) Welding procedure

The welding procedures are to comply with the requirements in (4) above.

(c) Examinations and tests

Test assembly is to be examined non-destructively and destructively in accordance with the **Table 5** and **Fig 6**.

**Table 5 Type of tests and extent of testing**

Type of test(1)	Extent of testing
Visual inspection	100% as per (d)
Liquid penetrant testing	100% as per (f)
Transverse tensile test	Two specimens as per (e)
Macro examination	Three specimens as per (g)
(Notes)	
(1) Bend or fracture test are at the discretion of the Society.	

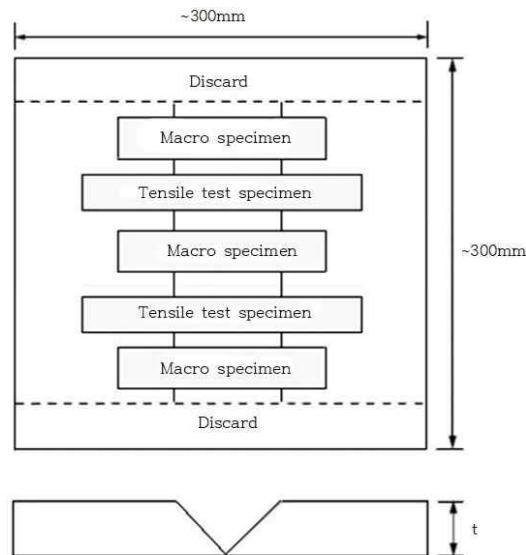


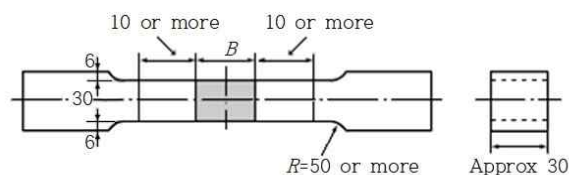
Fig 6 Test Specimen

## (d) Visual inspection

The welded surface is to be regular and uniform and free from harmful defects such as cracks and undercuts. Test assembly is to be examined by visual inspection prior to the cutting of test specimen. In case, that any post-weld heat treatment is required or specified, visual inspection is to be performed after heat treatment.

## (e) Tensile test

Tensile tests are to be carried out using the two test specimens taken in accordance with Fig 6, and the values obtained are to be less than those given in Table 6. The form of the test specimens are to comply with Fig 7. Alternatively tensile test specimens according to recognized standards acceptable to the Society may be used.



\*The welded surface is to be ground or machined flush with base metal

Fig 7 Size of Tensile Test Specimen (Unit : mm)

Table 6 Tensile Test Requirements for Approval Test

Material	Tensile Strength (N/mm <sup>2</sup> )
CU1	370 min.
CU2	410 min.
CU3	500 min.
CU4	550 min.

## (f) Non-destructive inspection

Test assembly is to be examined by liquid penetrant testing prior to the cutting of test specimen. In case, that any post-weld heat treatment is required or specified, non-destructive testing is to be performed after heat treatment. Imperfections detected by liquid penetrant testing are to be assessed in accordance with 2. (4). No cracks are permitted.

## (g) Macro-structure examination (2017)

Three test specimens are to be prepared and etched on one side to clearly reveal the weld metal, the fusion line and the heat affected zone (see Fig 6).

- 5 g iron(III) chloride
- 30 ml hydrochloric acid (cone)
- 100 ml water

The test specimens are to be examined for imperfections present in the weld metal and the heat affected zone. Cracks and lack of fusion are not permitted. Imperfections such as pores, or slag inclusions, greater than 3 mm are not permitted.

(C) *Test of mold cavity welding*

(i) Test piece and dimension of test piece

Test piece is to be of the material of same quality as the actual propeller. The dimensions of test piece are shown in Fig 8. The cavities are made as shown in the figure and then welding same as condition in the actual welding is carried out.

(ii) Sizes of cavities

Proper sizes permitting free operation of electrode.

(iii) Distribution of cavities

Distribution of cavities and distance of each cavity from the edge of test piece is to be such that these simulate the actual condition in the propeller to be welded.

(iv) Welding process

To be same as in the actual welding.

(v) Macro structure test

Macro structure test is to confirm that no defects such as crack exist in the cross sections of weld parts.

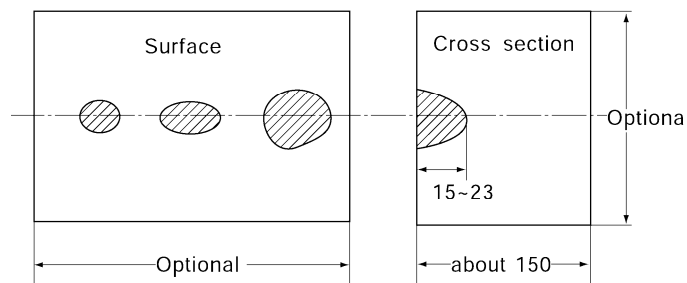


Fig 8 Test of mold cavity welding (Unit : mm)

(vi) Hardness test

Hardness test is to confirm that there is no unacceptable fluctuation in hardness between the deposit metal, base metal and heat-affected zones.

(vii) Non-destructive inspection (2017) (2020)

Welded joint is to be tested by liquid penetrant inspection and is to be free from any crack and other harmful defects.

(D) *Additional tests*

Where deemed necessary, additional tests may be requested by the Society.

(E) *Range of approval (2021)*

(a) General

(i) All the conditions of validity stated below are to be met independently of each other. Changes outside of the ranges specified are to require a new welding procedure test.

(ii) A qualification of a WPS obtained by a manufacturer is valid for welding in workshops or sites under the same technical and quality control of that manufacturer.

(b) Base metal

The range of qualification related to base metal is given in Table 7.

**Table 7 Range of qualification for base metal**

Copper alloy material grade used for qualification	Range of approval
<i>CU1</i>	<i>CU1</i>
<i>CU2</i>	<i>CU1, CU2</i>
<i>CU3</i>	<i>CU3</i>
<i>CU4</i>	<i>CU4</i>

## (c) Thickness

The qualification of a WPS carried out on a weld assembly of thickness *t* is valid for the thickness range given in **Table 8**.

**Table 8 Range of qualification for thickness**

Thickness of the test piece, <i>t</i> (mm)	Range of approval, <i>T</i> (mm)
$30 \leq t$	$3 \leq T$

## (d) Welding position

Approval for a test made in any position is restricted to that position.

## (e) Welding process

The approval is only valid for the welding process used in the welding procedure test. Single run is not qualified by multi-run butt weld test used.

## (f) Filler metal

The approval is only valid for the filler metal used in the welding procedure test.

## (g) Heat input

The upper limit of heat input approved is 25% greater than that used in welding the test piece. The lower limit of heat input approved is 25% lower than that used in welding the test piece.

## (h) Preheating and interpass temperature

The minimum preheating temperature is not to be less than that used in the qualification test. The maximum interpass temperature is not to be higher than that used in the qualification test.

## (i) Post-weld heat treatment

The heat treatment used in the qualification test is to be specified in pWPS. Soaking time may be adjusted as a function of thickness.

**5. Straightening****(1) Hot straightening**

- Weld repaired areas may be subject to hot straightening, provided it can be demonstrated that weld properties are not impaired by the hot straightening operations. (2021)
- Straightening of a bent propeller blade or pitch modification is to be carried out after heating the bent region and approximately 500 mm wide zones on either side of it to the suggested temperature range given in **Table 6**. The heating is to be slow and uniform and the concentrated flames such as oxy-acetylene and oxy-propane is not used.
- Sufficient time is to be allowed for the temperature to become fairly uniform through the full thickness of the blade section. The temperature must be maintained within the range given in **Table 9** through the straightening operation.

Table 9 Temperature Range for hot Straightening

Material	<i>CU1</i>	<i>CU2</i>	<i>CU3</i>	<i>CU4</i>
Temperature of hot straightening (°C)	500~800	500~800	700~900	700~850

(d) A thermocouple instrument or temperature indicating crayons are to be used for measuring the temperature.

(e) The area heated is to be enclosed with asbestos or similar material to reduce the cooling speed after straightening.

(2) **Cold straightening**

Cold straightening is to be used for minor repairs of tips and edge only. Cold straightening on *CU1*, *CU2* and *CU4* are to be followed by a stress relieving heat treatment(See **Table 3** and **Table 4**)

(3) **Application of load**

For hot straightening, static loading and dynamic loading are to be used, but for cold straightening, static loading is to be used only. ⚓

## Annex 2-7 Guidance for non-destructive testing of ship hull steel welds

### 1. General

#### (1) Application

- (A) This Guidance applies to the Non-destructive inspection for all hull welds of ships whose, in general, length exceeds 30 m to confirm the quality of the hull welds. Effective date of this Guidance is the date of contract for construction.
- (B) In ships of less than 30m in length, the range of the inspection, the members to be inspected and the number of checkpoints are to be determined by the Surveyor based on consultation with the manufacturer.
- (C) The quality levels given in this Guidance refer to production quality and not to fitness for-purpose of the welds examined.
- (D) The non-destructive testing is normally to be performed by the Shipbuilder or its subcontractors in accordance with this Guidance. Surveyor may require to witness some testing.
- (E) It should be the Shipbuilder's responsibility to assure that testing specifications and procedures are adhered to during the construction and the report is made available to the Society on the findings made by the NDT.
- (F) The extent of testing and the number of checkpoints are to be agreed between the Shipbuilder and the Society. For criticality of structure reference is to be made to **Pt 3 Ch 1 Sec 4** of the Rules of Structural Member Categories and **Pt 13** of the Rules. (2021)
- (G) This Guidance is intended to apply to welds of irons and nonferrous metals. Other marine structures may be applied subject to the approval by the Society. However, in case of ultrasonic inspection, the transducer design and calibration block material used are appropriate to the material under inspection.
- (H) These requirements cover conventional NDT methods. Advanced non-destructive testing (ANDT) methods such as phased array ultrasonic testing (PAUT), time of flight diffraction (TOFD), digital radiography (RT-D), radiosopic testing (RT-S), and computed radiography (RT-CR) are covered by **Annex 2-12**. (2021)

#### (2) Terms and definitions (2021)

The following terms and definitions apply for these requirements.

- (A) NDT(Non-Destructive Testing) – the development and application of technical methods to examine materials or components in ways that do not impair their future usefulness and serviceability, in order to measure geometrical characteristics and to detect, locate, measure and evaluate flaws. NDT is also known as non-destructive examination (NDE), non-destructive inspection (NDI) and non-destructive evaluation(NDE).
- (B) RT – Radiographic Testing
- (C) UT – Ultrasonic Testing
- (D) MT – Magnetic Particle Testing
- (E) PT – Dye or Liquid Penetrant Testing
- (F) PWHT – Post Weld Heat Treatment
- (G) VT – Visual Testing

#### (3) Welding processes (2021)

These requirements apply to fusion welds made using manual metal arc welding (shielded metal arc welding, 111), gas-shielded metal arc welding (gas metal arc welding, including flux cored arc welding, 13x), gas-shielded arc welding with non-consumable tungsten electrode (gas tungsten arc welding, 14x), submerged arc welding (12x), electro-slag welding (72x) and electro-gas welding processes (73). Terms and numbers according to *ISO 4063:2009* ("x" indicates that relevant subgroups are included). These requirements may also be applied to welding processes other than the above at the discretion of the Society.

#### (4) Weld joints (2021)

These requirements apply to butt welds with full penetration, tee, corner and cruciform joints with or without full penetration, and fillet welds.

#### (5) Means of Non-destructive Inspection

- (A) Applicable methods for testing of the different types of weld joints are given in **Table 1**.



Table 1 Applicable methods for testing of weld joints (2021)

Weld Joint	Parent material thickness(mm)	Applicable testing methods
Butt welds with full penetration	$t < 8^{(1)}$	VT, PT, MT, RT
	$t \geq 8$	VT, PT, MT, UT, RT
Tee joints, corner joints and cruciform joints with full penetration	$t < 8^{(1)}$	VT, PT, MT, RT <sup>(3)</sup>
	$t \geq 8$	VT, PT, MT, UT, RT <sup>(3)</sup>
Tee joints, corner joints and cruciform joints without full penetration and fillet welds	All	VT, PT, MT, UT <sup>(2)</sup> , RT <sup>(3)</sup>
Note: (1) In cases of thickness below 8mm, the Society may consider application of an appropriate advanced UT method. (2) UT can be used to monitor the extent of penetration in tee, corner and cruciform joints. This requirement is to be agreed with the Society. (3) RT may be applied however there will be limitations		

- (B) All welds over their full length are to be subject to VT by personnel designated by the Shipbuilder, who may be exempted from the qualification requirements defined in (7). (2021)
- (C) As far as practicable, PT or MT shall be used when investigating the outer surface of welds, checking the intermediate weld passes and back-gouged joints prior to subsequent passes deposition. MT shall be performed in ferromagnetic materials welds unless otherwise agreed with the Society. Surface inspection of important tee or corner joints, using an approved MT or PT method, shall be conducted to the satisfaction of the surveyor. (2021)
- (D) Non-destructive inspection for detection of internal imperfections is, in principle, to be radiographic inspection specified in 3. However, if the following (E) is satisfied, methods to be used shall be agreed with the Society. The method used shall be suited for the detection of particular types and orientations of discontinuities. RT and UT are used for detection of internal discontinuities, and in essence they supplement and complement each other. RT is generally most effective in detecting volumetric discontinuities (e.g. porosity and slag) whilst UT is more effective for detecting planar discontinuities (e.g. laminations, lack of fusion and cracks). Although one method may not be directly relatable to the other, either one would indicate conditions of inadequate control of the welding process. (2021)
- (E) For welded joints of hull construction in thickness of 8 mm and above, a part or all of radiographic inspection may be replaced by the ultrasonic inspection based on the requirements given in 4, in case that the shipyard submitting ultrasonic testing specifications containing information on the items mentioned below
- (a) Approval of inspection manual
 

Prior to carrying out the inspection, the shipyard has to submit the inspection manual containing the items mentioned below, and have the manual approved by the Society.

    - (i) Type of ultrasonic detector and kind of probe (nominal frequency and material, dimension, type and nominal angle of refraction of transducer), and the applicable range of the testing (thickness, welding process, etc.)
    - (ii) Calibration block and reference block for calibration
    - (iii) Kind of ultrasonic test process (Angle beam technique is to be of standard one), and extent of the measurements and method for sensitivity adjustment for the process
    - (iv) Judgement criteria for ultrasonic test (The criteria for angle beam technique test is to be in accordance with **Table 11**. For the other kind of ultrasonic test process, judgement criteria are to be described in detail.)
    - (v) Record of the results of ultrasonic test
    - (vi) List of operators and judges
  - (b) The capability of shipyard
 

The capability of shipyard about the reliability of the test methods is to be judged by the items mentioned below.

    - (i) Qualification of engineers

- (ii) Quality control conditions
- (iii) Reliability
- (iv) Keeping the Standards and their application ability
- (v) Documents for type, extent and repair of defects
- (c) Confirmation by radiographic inspection
  - (i) When the initial ultrasonic inspection is carried out according to this Guidance, ultrasonic testing for 1/10 of welds to be subject, based on the instructions of the Surveyor, to radiographic testing of at least three ships to confirm that the results match those of (a) (iv) and is approved by the Society for the consistence. However the confirmation by radiographic inspection can be waived for the shipyard which has the records to carry out confirmation inspection more than 3 ships.
- (F) Where a yard desires to use ultrasonic inspection as the primary inspection method according to (E), following requirements to be complied.
  - (a) a reasonable amount of checkpoints are to be examined by the radiography or alternative means approved by the Society. The amount examined together with the area covered are to be agreed and marked on the NDE plan specified in (5).
  - (b) Radiographic inspection may be required at random in important locations at the discretion of the Surveyor.
- (G) In case where shipyard intend to apply the new advanced NDT technologies such as Phased array UT (PAUT) or Time of Flight Diffraction (TOFD) in lieu of radiographic inspection, it is to be accordance with **Annex 2-12**. (2021)
- (H) Where the surveyor becomes aware that an NDT location has been repaired without a record of the original defect, the shipyard is to carry out additional examinations on adjacent areas to the repaired area to the satisfaction of the attending surveyor. Reference is to be made to **Pt 1, Annex 1-12** of the Guidance. (2021)
- (I) Welds in thick steels (>50 mm) used in container carrier, deck and hatch coaming areas are to be inspected in accordance with the additional requirements in **Pt 7, Annex 7-8** of the Guidance. (2021)
- (J) The testing method, equipment and conditions shall comply with recognized National or International standards, or other documents to the satisfaction of the Society. (2021)
- (K) Sufficient details shall be given in a written procedure for each NDT technique submitted to the Society for acceptance. (2021)
- (L) The testing volume shall be the zone which include the weld and parent material for at least 10 mm each side of the weld, or the width of the heat affected zone(HAZ), whichever is greater. In all cases inspection shall cover the whole testing volume. (2021)
- (M) Provision is to be made for the surveyor to verify the inspection, reports and records(e.g. radiographs) on request. (2021)
- (N) The additional non-destructive inspection required for workmanship control of welded joints of hull is to be in accordance with the requirements specified in **5 (2), (C)**.
- (6) **Testing apparatus**  
The testing apparatus of radiographic and ultrasonic Inspection are to be calibrated and/or corrected in accordance with the recognised national or international standards.
- (7) **Personnel requirements** (2021)
  - (a) The Shipbuilder or its subcontractors is responsible for the qualification and preferably 3rd party certification of its supervisors and operators to a recognised certification scheme based on *ISO 9712:2012*.
  - (b) Personnel qualification to an employer based qualification scheme as e.g. *SNT-TC-1A,2016* or *ANSI/ASNT CP-189,2016* may be accepted if the Shipbuilder or its subcontractors written practice is reviewed and found acceptable by the Society. The Shipbuilder or its subcontractors written practice shall as a minimum, except for the impartiality requirements of a certification body and/or authorised body, comply with *ISO 9712:2012*.
  - (c) The supervisors' and operators' certificates and competence shall comprise all industrial sectors and techniques being applied by the Shipbuilder or its subcontractors. Level 3 personnel shall be certified by an accredited certification body.
  - (d) The Shipbuilder or its subcontractors shall have a supervisor or supervisors, responsible for the appropriate execution of NDT operations and for the professional standard of the operators and their equipment, including the professional administration of the working procedures. The Shipbuilder or its subcontractors shall employ, on a full-time basis, at least one supervisor independently certified to Level 3 in the method(s) concerned as per the re-

quirements of (a)~(c) above. It is not permissible to appoint Level 3 personnel; they must be certified by an accredited certification body. It is recognised that a Shipbuilder or its subcontractors may not directly employ a Level 3 in all the stated methods practiced. In such cases, it is permissible to employ an external, independently certified, Level 3 in those methods not held by the full-time Level 3(s) of the Shipbuilder or its subcontractors.

- (e) The supervisor shall be directly involved in review and acceptance of NDT Procedures, NDT reports, calibration of NDT equipment and tools. The supervisor shall on behalf of the Shipbuilder or its subcontractors re-evaluate the qualification of the operators annually.
  - (f) The operator carrying out the NDT and interpreting indications, shall as a minimum, be qualified and certified to Level 2 in the NDT method(s) concerned and as described in (a)~(c) above. However, operators only undertaking the gathering of data using any NDT method and not performing data interpretation or data analysis may be qualified and certified as appropriate, at level 1.
  - (g) The operator shall have adequate knowledge of materials, welding, structures or components, NDT equipment and limitations that are sufficient to apply the relevant NDT method for each application appropriately.
- (8) **NDT plan**
- (A) The extent of testing and the associated quality levels are to be planned by the Shipbuilder according to the ship design, ship type and welding processes used. For new construction survey reference is to be made to the NDT requirements of **Pt 1, Annex 1-12** of the Guidance and the applicable parts of the Table 1 of **Pt 1, Annex 1-12** of the Guidance and Appendices. (2021)
  - (B) For each construction, the Shipbuilder shall submit a plan for approval by the Society, specifying the areas to be examined and the extent of testing and the quality levels, with reference to the NDT procedures to be used. Particular attention is to be paid to inspecting welds in highly stressed areas and welds in primary and special structure indicated in **Pt 3, Ch 1, Sec 4** of the Rules. The NDT procedure(s) shall meet the requirement stated in this **Annex** and the specific requirements of the Society. The plan shall only be released to the personnel in charge of the NDT and its supervision. (2021)
    - (a) In selecting checkpoints, emphasis shall be given to the following inspection locations:
      - Welds in high stressed areas
      - Fatigue sensitive areas
      - Other important structural elements
      - Welds which are inaccessible or very difficult to inspect in service
      - Field erected welds
      - Suspected problem areas
    - (b) Block construction welds performed in the yards, or at subcontracted yards/facilities, are to be considered in selecting checkpoints.
    - (c) For other marine and offshore structures the extent is to be agreed by the Society.
    - (d) If an unacceptable level of indications are found the NDT extent is to be increased.
  - (C) The identification system should identify the exact locations of the lengths of weld examined.
  - (D) Welded connections of large cast or forged components (e.g. stern frame, stern boss, rudder parts, shaft brackets...) are to be tested over their full length using MT (MT is the preferred method) or PT, (PT is to be applied for non-ferrous metals) and at agreed locations using RT or UT. (2021)
  - (E) In general start/stop points in welds made using automatic or fully mechanized welding processes are to be examined using RT or UT, except for internal members where the extent of testing is to be agreed with the attending surveyor. (2021)
  - (F) Tee joints with full penetration between corrugated bulkheads and inner bottom without lower stools should be tested minimum 10% for the number of corner part of corrugation. The 200 mm of corner part from side to side is to be examined by MT or PT and at agreed locations are to be examined by RT or UT. The surveyor may request the additional non-destructive testing according to the quality of workmanship of the shipyard. (2017)
- (9) **Timing of NDT**
- (a) NDT shall be conducted after welds have cooled to ambient temperature and after post weld heat treatment where applicable.
  - (b) For high strength steels for welded structure with specified minimum yield stress in the range of 420 N/mm<sup>2</sup> to 690 N/mm<sup>2</sup>, NDT shall not be carried out before 48 hours after completion of welding. For steel with specified minimum yield greater than 690 N/mm<sup>2</sup>, NDT

shall not be carried out before 72 hours after completion of welding. Regardless of yield strength consideration is to be given to requiring a delayed inspection where evidence of delayed cracking has been observed in production welds. (2021)

- (c) At the discretion of the surveyor, a longer interval and/or additional random inspection at a later period may be required, (for example in case of high thickness welds). (2021)
  - (d) At the discretion of the surveyor, the 72 hour interval may be reduced to 48 hours for RT or UT inspection, provided there is no indication of delayed cracking, and a complete visual and random MT or PT inspection to the satisfaction of the surveyor is conducted 72 hours after welds have been completed and cooled to ambient temperature. (2021)
  - (e) Where PWHT is carried out the requirement for testing after a delay period may be relaxed, at the discretion of the surveyor. (2021)
- (10) **Performance and responsibility**
- (a) The non-destructive testing is normally to be performed by the Shipbuilder or its subcontractors in accordance with inspection manual and NDE plan approved by the Society. The Surveyor may require to witness some testing.
  - (b) It should be the Shipbuilder's responsibility to assure that testing specifications and procedures are adhered to during the construction and the report is made available to the Society on the findings made by the NDT.
- (11) **Surface inspections**
- (a) Areas to be examined shall be free from scale, slag, loose rust, weld spatter, oil, grease, dirt or paint that might affect the sensitivity of the testing method. (2021)
  - (b) Preparation and cleaning of welds for subsequent NDT are to be in accordance with the accepted NDT procedures, and are to be to the satisfaction of the surveyor. Surface conditions that prevent proper interpretation may be cause for rejection of the weld area of interest. (2021)
  - (c) The surface of welds to be radiographed are to be sufficiently free from irregularities that may mask or interfere with interpretation
  - (d) The test surface (within I skip distance from welds edge) to be ultrasonic tested are free from spatter, floating scales, painting film, remarkable rust which prevent transmission of ultrasonic wave and the likes. They are removed if existed.

## 2. Visual testing (2021)

The personnel in charge of VT is to confirm that the surface condition is acceptable prior to carrying out the inspection. VT shall be carried out in accordance with standards agreed between the Shipbuilder and the Society.

## 3. Magnetic particle testing(MT)

- (1) MT shall be carried out in accordance to *ISO 17638:2016* or a recognized accepted standard by the Society. (2021)
- (2) The Shipbuilder shall submit a procedure for approval by the Surveyor, specifying the surface preparation, magnetizing equipment, calibration methods, detection media and application, viewing conditions and post demagnetization.
- (3) The surface to be examined shall be free from scale, weld spatter, oil, grease, dirt or paint and shall be clean and dry. In general, the inside and outside of the welds to be inspected need to be sufficiently free from irregularities that may mask or interfere with interpretation. (2021)
- (4) The extent of MT shall be in accordance to the plans agreed with the attending surveyor and to the satisfaction of the surveyor. (2021)
- (5) To ensure detection of discontinuities of any orientation, the welds are magnetized in two directions approximately perpendicular to each other with a maximum deviation of 30°. Adequate overlapping shall ensure testing of the whole zone.
- (6) Magnetic particle testing should cover a minimum weld length of 500 mm.

## 4. Liquid penetrant testing(PT)

- (1) PT shall be carried out in accordance to *ISO 3452-1:2013* or a recognized accepted standard by the Society. (2021)
- (2) The Shipbuilder should submit a procedure for approval by the Surveyor, specifying the calibration equipment, surface preparation, cleaning and drying prior to testing, temperature range, type of penetrant, cleaner and developer used, penetrant application and removal, penetration time, developer application and development time and lighting conditions during testing.
- (3) The surface to be examined shall be clean and free from scale, oil, grease, dirt or paint so

there are not contaminants and entrapped material that may impede penetration of the inspection media. (2021)

- (4) The temperature of parts examined should be typically between 5°C and 50°C, outside this temperature range special low/high temperature penetrant and reference comparator blocks should be used.
- (5) The extent of PT shall be in accordance to the plans agreed with the attending surveyor and to the satisfaction of the surveyor. (2021)
- (6) PT should cover a minimum weld length of 500 mm. (2021)

## 5. Radiographic Testing(RT)

### (1) Methods of radiography

- (A) RT shall be carried out in accordance to *ISO 17636-1:2022* or an accepted recognized standard by the Society (2021) (2023)
- (B) Test range of RT is to be not less than 250 mm or overall length of the welds inspected, whichever is smaller. However, For hull welds the minimum length inspected by RT is typically 300 mm. The minimum inspected weld length for each checkpoint is to be specified in the approved NDT plan. (2021)
- (C) The extent of RT shall be in accordance to the approved plans in accordance with (2) and to the satisfaction of the surveyor. (2021)
- (D) Processed films should display hull no., frame no., weld boundary indicators, Port/Starboard, location (or film serial number) and date as radiographic image.
- (E) Consideration may be given for reduction of inspection frequency for automated or fully mechanized welds where quality assurance techniques indicate consistent satisfactory quality. The number of checkpoints is to be increased if the proportion of non-conforming indications is abnormally high. (2021)
- (F) The inside and outside surfaces of the welds to be radiographed are to be sufficiently free from irregularities that may mask or interfere with interpretation. Surface conditions that prevent proper interpretation of radiographs may be cause for rejection of the weld area of interest. (2021)

### (2) Extent of survey

#### (A) Survey of welded joints of the shell and deck plating in ships

##### (a) The number of checkpoints

The minimum number of radiographic check points for the welded joints of the shell and deck plating in ships is to be governed by the following equation or the same as the length of the ship(m), (round off), whichever is the greater.

$$N = \frac{L(B+D)}{46.5}$$

where,

$N$  = minimum number of checkpoints

$L$  = length specified in **Pt 3, Ch 1, 102.** of the Rules (m)

$B$  = breadth specified in **Pt 3, Ch 1, 104.** of the Rules (m)

$D$  = depth specified in **Pt 3, Ch 1, 106.** of the Rules (m)

##### (b) Survey location and distribution of checkpoints

- (i) Survey location and distribution of checkpoints are to comply with the requirements in **Table 2.** These inspection spots are not to adjoin each other.
- (ii) In the distribution of checkpoints, the selection of inspection locations is to be considered the followings and carried out by the field Surveyor.
  - ① Welds in high stressed areas
  - ② Welds which are inaccessible or very difficult to inspection in service
  - ③ Intersections of field erected welds
- (iii) If the welds to be inspected can not be inspected because of the structure, other possible welds in the vicinity of that weld are to be subjected to radiographic inspection.

**Table 2 Survey location and distribution of checkpoints for the welded joints of the shell and deck plating in ships**

Survey location	distribution of checkpoints	
	Butt welds within 0.6 L midship	Butt welds outside 0.6 L midship
(1) Strength deck(excluding the area within hatch side lines) (2) Sheer strake, (3) Side shell plating, (4) bilge strake (5) Bottom shell plating, (including flat plate keel.) (6) Hatch side coaming(including the top plate) <sup>(1)</sup>	$N^{(2)}$	$\frac{1}{10}N$
Note (1) Butt joints of the hatch side coaming exceeding 0.15L in length. (2) one-third of the number of checkpoints is to be the intersections of weld lines.		

**(B) Survey of welded joints of internal structural members of ships**

- (a) Survey location and distribution of checkpoints are to comply with **Table 3**. These inspection spots are not to adjoin each other.  
(b) Distribution of checkpoints is to be as specified in (2), (A), (b), (ii)

**Table 3 Survey location and distribution of checkpoints for the welded joints of internal structural members of ships (2021)**

Survey location	distribution of checkpoints <sup>(1)(2)</sup>	
	within 0.6L midship	outside 0.6L midship
	Butt welds	
(1) Web and face plates of longitudinal members on the strength deck (deck longitudinal, girders under deck and above deck).(longitudinal on the deck within the side lines of a cargo hatch opening are excluded.)	$\frac{1}{8}L$	$\frac{1}{40}L$
(2) Uppermost steel plate of longitudinal bulkheads.	$\frac{1}{8}L$	$\frac{1}{40}L$
(3) Lowermost plate of the longitudinal bulkhead.	$\frac{1}{16}L$	$\frac{1}{40}L$
(4) Web and face plates of longitudinal members (longitudinal frames, centerline girder plate, etc.) on sheer strake, shell plating, turn of bilge strake and keel plate.	$\frac{1}{16}L$	$\frac{1}{40}L$
(5) Web and face plates of transverse and horizontal girders.	$\frac{1}{16}L$	$\frac{1}{40}L$
Note (1) Number of inspections is to round up decimal places per joints of each members subject to inspections. (2) Distribution of number of inspections may change in consideration of the type of ship, structural arrangement, welding process, arrangement of joints, etc.		

**(C) Workmanship control of welded joints of hull**

- (a) In addition to preceding (A) and (B), non-destructive testing may be required additionally for parts of start, interrupted and end points of automatic welded joints, welded joints of hatch corner, connections of stern frame or rudder horn made of casting steel to rolled steels for hull, welded joints of insert plate for working holes and welded joints in the

- vicinity of parts where stress is concentrated.
- (b) In addition to (a) above, non-destructive testing may be required additionally for the areas where welding workmanship is suspect, the areas where new welding methods have been adopted, the areas where defects are liable to occur easily, the welds which are inaccessible or very difficult to inspect in service and other appropriate areas deemed necessary by the Surveyor to encourage good welding work.
  - (c) The locations of and the number of joints to be inspected additionally according to (a) and (b) above are to be appropriately decided by the Surveyor according to the actual status of workmanship of the shipyard.
- (D) *Addition/Reduction in the number of checkpoints*
- (a) If it is deemed necessary in considering the results of visual inspection for welds of the members, the Surveyor may require, additional non-destructive inspections for welds other than those subject to non-destructive inspection, or alteration of non-destructive inspection procedure.
  - (b) If the survey results (before repair) of a previously constructed ship show that the number of welds that need to be repaired exceeds 20% of the total number of locations, then the number of checkpoints is to be a minimum of twice the number required.
  - (c) If automatic welding has been carried out at joints to be surveyed and the results of the survey verify that the quality of the welding procedure is consistent satisfactory quality, the number of checkpoints may appropriately be reduced.
  - (d) If a weld that needs to be repaired is found from automatically welded joints whose number has been reduced in accordance with (c), additional radiographs amounting to the number of checkpoints as prescribed in (c), are to be taken immediately. The number of checkpoints is not to be reduced until an appropriate period has elapsed and the quality is verified to be stable and satisfactory.
  - (e) For ships whose length 120 m or under, the survey locations and the number of checkpoints can be reduced.

## 6. Ultrasonic Testing(UT)

### (1) Methods of ultrasonic testing

- (A) UT shall be carried out according to procedure based on *ISO 17640:2018*(testing procedure), *ISO 23279:2017* (characterization) and *ISO 11666:2018*(acceptance levels) or accepted standards by the Society. (2021)
- (B) The minimum inspected weld length for each checkpoint is to be specified in the approved NDT plan in accordance with (2). (2021)
- (C) The extent of UT shall be in accordance to the approved plans in accordance with (2) and to the satisfaction of the surveyor. (2021)
- (D) In general, the scanning of weld is performed by using angle beam technique. However, normal beam technique is applied to the place where the application of angle beam technique is difficult or the place specially specified as that where the other technique are more suitable than angle beam technique for detecting a discontinuity.
- (E) The stage of the test is the time when the final heat treatment is completed, in the case where heat treatment or the like after completion of weld has been specified in the document.
- (F) The test of parent materials of the part through which ultrasonic waves pass when angle beam technique is performed, are previously tested normal technique to detect a discontinuity such as lamination etc.
- (G) The probes may be affixed to suitable wedges designed to induce beam waves in the material under test at the selected angles.
- (H) The couplant, in general, is to be used the glycerine-water solution of 75 % or more. The kinds and temperature of the couplant used for test are to be equivalent to those used for calibration of ultrasonic test instrument.
- (I) The weld reinforcement is adequately finished in case where its form affects the results of the test.

### (2) Extent of survey

- (A) Survey of welded joints of the shell and deck plating in ships
  - (a) The survey location and distribution of checkpoints of ultrasonic inspection are to comply with the requirements given in (A) of 5 (2).
  - (b) Test range of ultrasonic inspection is entire length of the joint or 750 mm, whichever is

smaller.

- (B) Survey of welded joints of internal structural members of ships
- The survey location and distribution of checkpoints of ultrasonic inspection are to comply with the requirements given in (B) of 5 (2).
  - Test range of ultrasonic inspection is entire length of the joint or 300 mm, whichever is smaller.
- (C) Workmanship control of welded joints of hull
- The survey location and distribution of checkpoints of ultrasonic inspection for workmanship control of welded joints of hull are to comply with the requirements given in (C) of 5 (2).
  - Test range of ultrasonic inspection is to comply with the requirements given in (B) above.
- (D) Addition/Reduction in the number of checkpoints  
Addition/reduction in the number of checkpoints is to comply with the requirements given in (D) of 5 (2).

## 7. Acceptance Levels(criteria) (2021)

### (1) General

- This requirement details the acceptance levels (criteria) followed for the assessment of the NDT results. Techniques include but are not limited to: VT, MT, PT, RT and UT.
- As far as necessary, testing techniques shall be combined to facilitate the assessment of indications against the acceptance criteria.
- The assessment of indications not covered by this document shall be made in accordance with a standard agreed with the Society. Alternative acceptance criteria can be agreed with the Society, provided equivalency is established.
- The general accepted methods for testing of welds are provided in **Table 4** and **Table 5** for surface and embedded discontinuities respectively. Refer to *ISO 17635:2016*.

**Table 4 Method for detection of surface discontinuities(All type of welds including fillet welds)**

Materials	Testing Methods
Ferritic Steel	VT
	VT, MT
	VT, PT

**Table 5 NDT for detection of embedded discontinuities (for butt and T joints with full penetration)**

Materials and type of joint	Nominal thickness (t) of the parent material to be welded (mm)		
	t < 8	8 ≤ t ≤ 40	t > 40
Ferritic butt-joints	RT or UT <sup>(1)</sup>	RT or UT	UT or RT <sup>(2)</sup>
Ferritic T-joints	UT <sup>(1)</sup> or RT <sup>(2)</sup>	UT or RT <sup>(2)</sup>	UT or RT <sup>(2)</sup>

Note:

- Below 8mm the Society may consider application of an appropriate advanced UT method.
- RT may be applied however there will be limitations.

### (2) Quality Levels

- Testing requirements follows the designation of a particular quality level of imperfections in fusion-welded joints in accordance with *ISO 5817:2014*. Three quality levels (B, C and D) are specified.
- In general Quality level C is to be applied for hull structure.
- Quality level B corresponds to the highest requirement on the finished weld, and may be



applied on critical welds.

- (D) This standard applies to steel materials with thickness above 0.5 mm. *ISO 5817:2014* **Table 1** provides the requirements on the limits of imperfections for each quality level. *ISO 5817:2014* Annex A also provides examples for the determination of percentage of imperfections (number of pores in surface percent).
- (E) All levels (B,C and D) refer to production quality and not to the fitness for purpose (ability of product, process or service to serve a defined purpose under specific conditions). The correlation between the quality levels defined in *ISO 5817:2014*, testing levels/techniques and acceptance levels (for each NDT technique) will serve to define the purpose under specific conditions. The acceptance level required for examination shall be agreed with the Society. This will determine the quality level required in accordance with the non-destructive technique selected. Refer to **Tables 6 to 11**.

### (3) Testing Levels

(A) The testing coverage and thus the probability of detection increases from testing level A to testing level C. The testing level shall be agreed with the Society. Testing level D is intended for special applications, this can only be used when defined by specification. *ISO 17640:2018* Annex A tables A.1 to A.7 provide guidance on the selection of testing levels for all type of joints in relation to the thickness of parent material and inspection requirements.

(B) The testing technique used for the assessment of indications shall also be specified.

### (4) Acceptance Levels

(A) The acceptance levels are specified for each testing technique used for performing the inspection. The criteria applied is to comply with each standard identified in **Tables 6 to 11** (or any recognized acceptable standard agreed with the Society).

(B) Probability of detection (POD) indicates the probability that a testing technique will detect a given flaw.

#### (C) Visual testing(VT)

The acceptance levels and required quality levels for VT are provided in IACS Rec 47 and **Table 6** below.

**Table 6 Visual testing**

Quality Levels (ISO 5817:2014 applies) <sup>(1)</sup>	Testing Techniques/ levels (ISO 17637:2016 applies) <sup>(1)</sup>	Acceptance levels <sup>(2)</sup>
B	Level not specified	B
C		C
D		D
Note:		
(1) Or any recognized standard agreed with the Society and demonstrated to be acceptable		
(2) The acceptance levels for VT are the same to the quality levels requirements of <b>ISO 5817:2014</b>		

#### (D) Liquid Penetrant testing(PT)

The acceptance levels and required quality levels for PT are provided in **Table 7** below.

Table 7 Liquid Penetrant Testing

Quality Levels (ISO 5817:2014 applies) <sup>(1)</sup>	Testing Techniques/ levels (ISO 3452-1:2013 applies) <sup>(1)</sup>	Acceptance levels (ISO 23277:2015 applies) <sup>(1)</sup>
B	Level not specified	2X
C		2X
D		3X
Note: (1) Or any recognized standard agreed with the Society and demonstrated to be acceptable		

## (E) Magnetic Particle testing(MT)

The acceptance levels and required quality levels for MT is provided in **Table 8** below.

Table 8 Magnetic Particle Testing

Quality Levels (ISO 5817:2014 applies) <sup>(1)</sup>	Testing Techniques/ levels (ISO 17638:2016 applies) <sup>(1)</sup>	Acceptance levels (ISO 23278:2015 applies) <sup>(1)</sup>
B	Level not specified	2X
C		2X
D		3X
Note: (1) Or any recognized standard agreed with the Society and demonstrated to be acceptable		

## (F) Radiographic testing(RT)

The acceptance levels and required quality levels for RT are provided in **Table 9** below. Reference radiographs for the assessment of weld imperfections shall be provided in accordance to *ISO 5817:2014* or acceptable recognized standard agreed with the Society.

Table 9 Radiographic Testing (2023)

Quality Levels (ISO 5817:2014 applies) <sup>(1)</sup>	Testing Techniques/ levels (ISO 17636-1:2022 applies) <sup>(1)</sup>	Acceptance levels (ISO 10675-1:2021 applies) <sup>(1)</sup>
B	B(class)	1
C	B <sup>(2)</sup> (class)	2
D	At least A (class)	3
Note: (1) Or any recognized standard agreed with the Society and demonstrated to be acceptable (2) For circumferential weld testing, the minimum number of exposures may correspond to the requirements of <b>ISO 17636-1:2022</b> , class A		

## (G) Ultrasonic testing(UT)

(a) The acceptance levels and required quality levels for UT are provided in **Tables 10** and **11** below.

Table 10 Ultrasonic Testing

Quality Levels (ISO 5817:2014 applies) <sup>(1)(2)</sup>	Testing Techniques/Levels (ISO 17640:2018 applies) <sup>(1)(2)</sup>	Acceptance Levels (ISO 11666:2018 applies) <sup>(1)</sup>
B	at least B	2
C	at least A	3
D	at least A	3 <sup>(3)</sup>

Note:

(1) Or any recognized standard agreed with the Society and demonstrated to be acceptable

(2) When characterization of indications is required, ISO 23279:2017 is to be applied

(3) UT is not recommended but can be defined in a specification with same requirement as Quality Level C

Table 11 Recommended Testing and Quality Levels (ISO 17640)

Testing Level <sup>(1)(2)(3)</sup> (ISO 17640:2018 applies)	Quality Level (ISO 5817:2014 applies)
A	C, D
B	B
C	By agreement
D	Special application

Note:

(1) POD increases from testing level A to C as testing coverage increases

(2) Testing Level D for special application shall be agreed with the Society

(3) Specific requirements for testing levels A to C, are provided for various types of joints in ISO 17460:2018 Annex A

(b) UT Acceptance Levels apply to the examination of full penetration ferritic steel welds, with thickness from 8 mm to 100 mm. The nominal frequency of probes used shall be between 2 MHz and 5 MHz. Examination procedures for other type of welds, material, thicknesses above 100 mm and examination conditions shall be submitted to the consideration of the Society.

(c) The acceptance levels for UT of welds are to be defined in accordance to ISO 11666:2018 requirements or any recognized acceptable standard agreed with the Society. The standard specifies acceptance level 2 and 3 for full penetration welded joints in ferritic steels, corresponding to quality levels B and C (Refer to **Table 10**).

(d) **Sensitivity settings and levels**

The sensitivity levels are set by the following techniques.

- (i) Technique 1: based on 3mm diameter side-drilled holes
- (ii) Technique 2: based on distance gain size (DGS) curves for flat bottom holes (diskshaped reflectors)
- (iii) Technique 3: using a distance-amplitude-corrected (DAC) curve of a rectangular notch of 1mm depth and 1mm width
- (iv) Technique 4: using the tandem technique with reference to a 6mm diameter flat-bottom hole (disk shaped reflector)

(e) The evaluation levels (reference, evaluative, recording and acceptance) are specified in ISO 11666:2018 Annex A.

(5) **Acceptance criteria when no quality level is specified**

(A) If the acceptance level cannot be determined pursuant to (4) above because the quality level is not specified, these requirements can be followed.

(B) Acceptance criteria for visual testing, magnetic particle and liquid penetrant testing are given in **Table 12**. Only the indications which have any dimension greater than 2 mm should re-

quire evaluation for MT&PT.

**Table 12 Acceptance criteria for visual testing, magnetic particle and liquid penetrant testing**

Surface discontinuity	Acceptance criteria for visual testing
Crack	not accepted
Lack of fusion	not accepted
Incomplete root penetration in butt joints welded from one side	not accepted
Surface pore	Single pore diameter $d \leq 0.25t^{(1)}$ for butt welds ( $d \leq 0.25a^{(1)}$ for fillet welds) with maximum diameter 3mm; 2.5d as minimum distance to adjacent pore.
Undercut in butt welds	depth $\leq 0.5\text{mm}$ whatever is the length depth $\leq 0.8\text{mm}$ with a maximum continuous <sup>(2)</sup> length of 90mm
Undercut in fillet welds	depth $\leq 0.8\text{mm}$ whatever is the length
Note: (1) "t" is the plate thickness of the thinnest plate and "a" is the throat of the fillet weld. (2) Adjacent undercuts separated by a distance shorter than the shortest undercut should be regarded as a single continuous undercut.	

(C) Acceptance criteria for RT

(a) *Classification of Defects*

(i) Classification of defects is to be as given in **Table 13**.

**Table 13 Classification of defects**

Types of defects	Kind of defects
Type 1	Porosity(blow hole) and similar defects
Type 2	Elongated slag inclusion, pipe, incomplete penetration, incomplete fusion, and similar defects
Type 3	Crack and similar defects

(ii) Where it is difficult to classify the defects into type 1 or type 2, classify respective defects into type 1 or type 2, and then decide whether or not the results are acceptable.

(iii) In case of butt welded joints between plates with different thickness, thickness of the thinner plate is taken.

(b) *Defect of Type 1*

(i) Size of defect of type 1 is to be represented by score and maximum length of the defect. The test field vision specified in **Table 15** is to be selected from radiographic so that the defects of maximum size exists and the sum of size of defects is maximum. Where the flaw falls on the boundary of the test field of vision, the part outside the test field of vision shall be included for measurement.

(ii) The score of defect in the case of single defect of type 1 shall be determined by using the value in **Table 14** according to the dimension of the major diameter of the defect. The score of defect for two or more defect of type 1 shall be the grand total of the score for each defect in the test field of vision.

Table 14 Score of defect

Units : mm

Major diameter of flaw (mm)	Up to and incl. 1.0	Over 1.0, up to and incl. 2.0	Over 2.0, up to and incl. 3.0	Over 3.0, up to and incl. 4.0	Over 4.0, up to and incl. 6.0	Over 6.0, up to and incl. 8.0	Over 8.0
Score	1	2	3	6	10	15	25

- (iii) The defects of type 1 are to be judged unacceptable, if the size of the defects exceeds the value of acceptable criteria specified in **Table 15**.

Table 15 Acceptance criteria for type 1 defect

	Thickness of base metal t(mm)	t ≤ 10	10 < t ≤ 25	25 < t ≤ 50	50 < t ≤ 100
		Test field of vision	10 mm × 10 mm		10 mm × 20 mm
Acceptance criteria	Maximum size of single defect (mm)	4	5	t/5	10
	Total score of defect	6	12	24	30

Note  
(1) Where the thickness of base metal is not more than 25 mm, the defects of not more than 0.5 mm may be ignored. Where the thickness of base metal is more than 25 mm, the defects of not more than 0.7 mm may be ignored.

(c) Defect of Type 2

- (i) Size of defect of type 2 is to be represented by length of the defect. Where defects are present in a row and the distance between the mutual defects does not exceed the length of larger defect, the sizes of all defects including the spaces between the mutual defects is to be considered as the length of the defect.
- (ii) The defects of type 2 are to be judged unacceptable, if the length of a defect exceeds the value of acceptable criteria specified in **Table 16**.
- (iii) Incomplete root penetration is not accepted in butt joint welded from one side.

Table 16 Acceptance criteria for type 2 defect

	Thickness of base metal t (mm)	t ≤ 12	12 < t ≤ 50	50 < t
Acceptance criteria	Sum of size of defect (mm)	6 or under	t/2 or under	24 or under

(d) Defect of Type 3

Any defect of type 3 is to be judged unacceptable.

(e) In Case of Coexistence of Defects of Type 1 and Type 2

Where two or more types of defects are coexistent, the defects are to be judged unacceptable, provided the size of defects of each type are more than half of the size specified in **Table 15** and **Table 16** respectively.

(D) Acceptance criteria for UT

- (a) The inspection methods are to comply with *KS B 0896* (Method for ultrasonic examination for welds of ferritic steel)
- (b) Making of curve for dividing echo height
- (i) Curve for dividing echo height  
The height for evaluation of the depth is made for four regions specified in **Fig 2**. The positions of probe for making the curves for dividing echo height using the distance amplitude characteristic curve are to comply with **Fig 1**.
- (ii) Determination of H line, M line and L line  
The curve for dividing echo height by working sensitivity of (d) is selected to take it as H line, and the curve for dividing echo height lower than H line by 6 dB is taken as M line and the curve lower than H line by 12 dB is taken as L line. H line is of

- over 40 %.
- (iii) Regions  
The regions divided by H, M and L line are designated as given in **Table 17** and the examples of regional division are indicated as given in **Fig 2**.

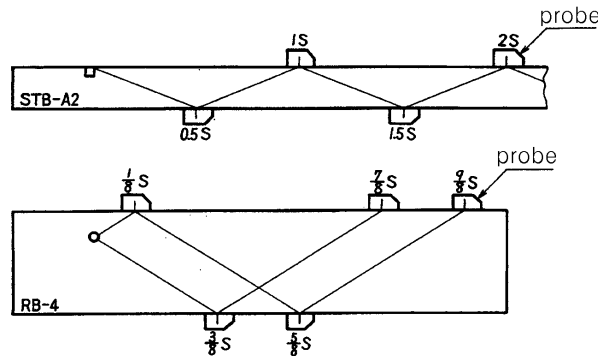


Fig 1 Position of Probe for making the Curves for Dividing Echo Height

An example in which the third dividing line from the lowest is taken as H line in the case where the time base range is 125mm and path length used for evaluation is 85mm.

An example in which the third dividing line is taken as H line in the case where the time base range is 125mm and path length used for evaluation is 75mm to 115mm.

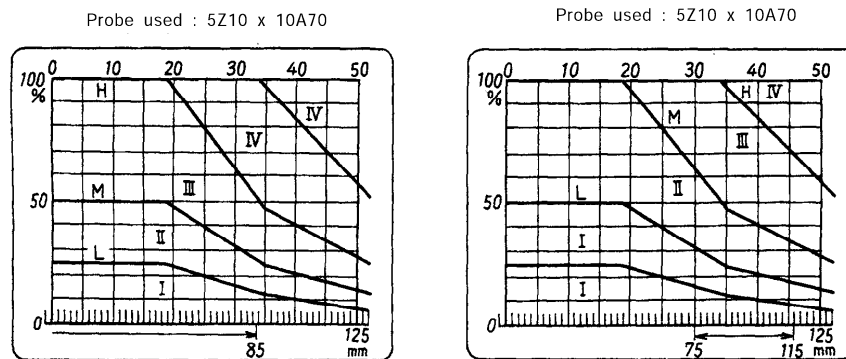


Fig 2 Examples for Drawing Curves for Dividing Echo Height

Table 17 Designation of Regional Division of Echo Height

Range of echo height	Region of echo height
L line or less	I
Over L to M line incl.	II
Over M to H line incl.	III
Over H line	IV

- (c) Acceptance Criteria
- (i) Defects detected by ultrasonic inspection are to be judged in accordance with **Table 18**.
- (ii) Where kind of defect is considered as cracks from welding process, location of defects, etc., the defects are to be judged unacceptable.

Table 18 Acceptance criteria for defects detected by ultrasonic inspection

	Thickness of base metal t (mm)	t ≤ 50	50 < t	t ≤ 50	50 < t
	Region of maximum echo heights	II and III		IV	
Acceptance Criteria	length of defect (mm)	t or less	50 or less	t/2 or less	25 or less
Note:					
1. (1) The symbol t is plate thickness (mm) of the parents materials of the groove side. However, in the case of butt joint weld with different plate thickness of the parents materials, the thinner plate thickness is adopted.					
2. In applying this table, in the case where the distance between discontinuities is smaller or equal to the length of the discontinuity with longer ultrasonic discontinuity length that the depth considered to be same, these discontinuities are regarded as same discontinuity group and treated as a continuous discontinuity including such distance. In the case where the distance between discontinuities is longer than the larger one out of the both ultrasonic discontinuity lengths, these discontinuities are regarded as independent from each other. The examination results of straddle scanning, parallel scanning by slanted probe and longitudinal scanning on the weld line are classified in accordance with the agreement between the parties concerned.					

## 8. Reporting (2021)

- (1) Reports of NDT required shall be prepared by the Shipbuilder and shall be made available to the Society.
- (2) Reports of NDT shall include the following generic items:
  - (A) Date of testing
  - (B) Hull number, location and length of weld inspected
  - (C) Names, qualification level and signature of personnel that have performed the testing
  - (D) Identification of the component examined
  - (E) Identification of the welds examined
  - (F) Steel grade, type of joint, thickness of parent material, welding process
  - (G) Acceptance criteria
  - (H) Testing standards used
  - (I) Testing equipment and arrangement used
  - (J) Any test limitations, viewing conditions and temperature
  - (K) Results of testing with reference to acceptance criteria, location and size of reportable indications
  - (L) Statement of acceptance/non-acceptance, evaluation date, name and signature of evaluator
  - (M) Number of repairs if specific area repaired more than twice
- (3) In addition to generic items of (2) above, reports of **PT** shall include the following specific items:
  - (A) Type of penetrant, cleaner and developer used
  - (B) Penetration time and development time
- (4) In addition to generic items, reports of **MT** shall include the following specific items:
  - (A) Type of magnetization
  - (B) Magnetic field strength
  - (C) Detection media
  - (D) Viewing conditions
  - (E) Demagnetization, if required
- (5) In addition to generic items, reports of **RT** shall include the following specific items:
  - (A) Type and size of radiation source (width of radiation source), X-ray voltage
  - (B) Type of film/designation and number of film in each film holder/cassette
  - (C) Number of radiographs (exposures)
  - (D) Type of intensifying screens
  - (E) Exposure technique, time of exposure and source-to-film distance as per below:
  - (F) Distance from radiation source to weld
  - (G) Distance from source side of the weld to radiographic film
  - (H) Angle of radiation beam through the weld (from normal)
  - (I) Sensitivity, type and position of IQI (source side or film side)
  - (J) Density

- (K) Geometric un-sharpness
- (L) Specific acceptance class criteria for RT

Examinations used for acceptance or rejection of welds shall be recorded in an acceptable medium. A written record providing following information: identification and description of welds, procedures and equipment used, location within recorded medium and results shall be included. The control of documentation unprocessed original images and digitally processes images is to be to the satisfaction of the surveyor.

The Society may require to duplicate some radiographs in order that some processed films are handed over to the Society together with testing reports. Alternative method to duplicate the processed film can be agreed with the Society.

- (6) In addition to generic items, reports of UT shall include the following specific items:
  - (A) Type and identification of ultrasonic equipment used (instrument maker, model, series number), probes (instrument maker, serial number), transducer type (angle, serial number and frequency) and type of couplant (brand)
  - (B) Sensitivity levels calibrated and applied for each probe
  - (C) Transfer loss correction applied Type of reference blocks
  - (D) Signal response used for defect detection
  - (E) Reflections interpreted as failing to meet acceptance criteria

The method for review and evaluation of UT reports is required for adequate quality control and is to be to the satisfaction of the surveyor.

- (7) The shipyard is to keep the inspection records specified in (2) to (6) of this document for at least for 5 years.

#### 9. Unacceptable indications and repairs (2021)

- (1) Unacceptable indications shall be eliminated and repaired where necessary. The repair welds are to be examined on their full length using appropriate NDT method at the discretion of the Surveyor.
- (2) When unacceptable indications are found, additional areas of the same weld length shall be examined unless it is agreed with the surveyor and fabricator that the indication is isolated without any doubt. In case of automatic or fully mechanized welded joints, additional NDT shall be extended to all areas of the same weld length.
- (3) All radiographs exhibiting non-conforming indications are to be brought to the attention of the surveyor. Such welds are to be repaired and inspected as required by the surveyor. When non-conforming indications are observed at the end of a radiograph, additional RT is generally required to determine their extent. As an alternative, the extent of non-conforming welds may be ascertained by excavation, when approved by the surveyor.
- (4) The extent of testing can be extended at the surveyor's discretion when repeated nonacceptable discontinuities are found.
- (5) The inspection records specified in **8.** are to include the records of repaired welds.
- (6) The Shipbuilder shall take appropriate actions to monitor and improve the quality of welds to the required level. The repair rate is to be recorded by the shipyard and any necessary corrective actions are to be identified in the builder's QA system.

#### 10. Improvement of qualification

Where the faulty welds are more than 10 % of the number of inspection specified in **Table 2** or **3**, the results of investigation on the substantial cause and the measures to improve the quality are to be submitted to the Surveyor. ↓



## Annex 2-8 Reinforced plastic materials

### 1. General

#### (1) Application

- (A) This Guidance applies to the base materials such as thermosetting resins, fiber reinforcements and core materials (hereinafter refer to FRP materials) used in the construction or repair of FRP ships, composite vessels and other marine structures which are to be certified or are intended for classification.
- (B) FRP materials or hybrid materials other than those prescribed in this Guidance may be used where specially approved in connection with the design. In such cases, the detailed data relating to the manufacturing process and mechanical properties, etc. of the materials are to be submitted for approval.

#### (2) Approval

- (A) FRP materials such as thermosetting resins, fiber reinforcements, core materials, etc. are to be type approved in accordance with this Guidance and the Guidance specially specified by the Society in advance
- (B) The manufacturing process of FRP ships, composite vessels or other marine structures which are to be certified or are intended for classification is to be approved in accordance with the Guidance specially specified by the Society in advance
- (C) In order that a FRP materials can be approved, the manufacturer is required to demonstrate to the satisfaction of the Society that the necessary manufacturing and testing facilities are available and are supervised by qualified personnel.

#### (3) Manufacturing control

- (A) It is the manufacturer's responsibility to assure that effective process and production controls in operation are adhered to within the manufacturing specifications.
- (B) Where control imperfection inducing possible inferior quality of FRP materials occurs, the manufacturer is to identify the cause and establish a countermeasure to prevent its recurrence. Also, the complete investigation report is to be submitted to the Surveyor.
- (C) For further use, each FRP material affected by previous (B) is to be tested to the Surveyor's satisfaction. The frequency of testing for subsequent products offered may be increased to gain confidence in the quality at the discretion of the Society.
- (D) The manufacturer is to provide the material producer with such information as is essential to ensure that the FRP materials to be used are in accordance with the approval requirements and the product specification. This information is to include any survey requirements for the materials.
- (E) Post-cure heating is to be carried out in properly constructed ovens which are efficiently maintained and have adequate means for control and recording of temperature. The oven is to be such as to allow the whole item to be uniformly heated to the necessary temperature. In the case of very large components which require post-cure heating, alternative methods will be specially considered.

#### (4) Retest procedure

- (A) Where test material fails to meet the specified requirement, two additional tests of the same type may be made at the discretion of the Surveyor.
- (B) Where an individual test result in a group (minimum five) deviates from the mean by more than two standard deviations in either the higher or lower direction, the result is to be excluded and a re-test made. Excluded results of tests are to be reported with confirmation that they have been excluded. Only one exclusion is acceptable in any group of tests.

#### (5) Quality

- (A) FRP materials are to be free from surface or internal defects which would be prejudicial to their proper application in service.
- (B) In the event of any material proving unsatisfactory during subsequent working or fabrication, such material may be rejected, notwithstanding any previous satisfactory testing and/or certification where the Surveyor considers necessary.

#### (6) Identification and marking of materials

- (A) The manufacturer of approved FRP materials is to identify each batch with a unique number or code.
- (B) The manufacturer of FRP products is to adopt a system of identification which will enable all finished products to be traced to the original batches of base materials. Surveyors are to be

given full facilities for tracing any component or material when required.

(7) **Certification**

The manufacturer is to provide the purchaser with test reports or certificates of conformity for each batch of FRP material supplied indicating the relevant values are to comply with this Guidance.

**2. Thermosetting resins**

- (1) The test methods for thermosetting resin are to be in accordance with the Guidance specially specified by the Society.
- (2) Minimum property values of gel coat resins are to comply with the values specified in **Table 1**.

**Table 1 Minimum property values of gel coat resins**

Properties	Minimum value
Tensile strength (stress at maximum load)	40 N/mm <sup>2</sup>
Tensile stress at break	40 N/mm <sup>2</sup>
Tensile strain at maximum load	2.5 %
Modulus of elasticity in tension	As measured
Flexural strength (stress at maximum load)	80 N/mm <sup>2</sup>
Modulus of elasticity in flexure	As measured
Barcol hardness	35
Determination of water absorption.	60 °C
Water absorption	60 mg(max.)
Specific gravity of cast resin	As measured

- (3) Minimum property values of cast thermosetting resins are to comply with the values specified in **Table 2**.

**Table 2 Minimum property values of cast thermosetting resins**

Properties	Minimum value
Tensile strength (stress at maximum load)	40 N/mm <sup>2</sup>
Tensile stress at break	40 N/mm <sup>2</sup>
Tensile strain at maximum load	2.0 %
Modulus of elasticity in tension	As measured
Flexural strength (stress at maximum load)	70 N/mm <sup>2</sup>
Modulus of elasticity in flexure	As measured
Barcol hardness	35
Determination of water absorption.	60 °C
Water absorption	70 mg(max.)
Specific gravity of cast resin	As measured

- (4) The polyester containing wax or other material that deteriorate bonding are to be additionally carried out interlaminar shear strength test (KS M ISO 14130). Minimum property values are in accordance with **Table 3**.

**3. Fiber reinforcements**

- (1) The following tests are to be made on each fiber reinforcement other than carbon fiber reinforcement (2020):
  - (A) Tensile strength (stress at maximum load).
  - (B) Tensile strain at break.
  - (C) Tensile secant modulus at 0,5 per cent and 0,25 per cent strain respectively.
  - (D) Compressive strength (stress at maximum load).
  - (E) Compressive modulus.
  - (F) Flexural strength (stress at maximum load).
  - (G) Modulus of elasticity in flexure.
  - (H) Apparent interlaminar shear.

- (I) Fibre content.
- (J) Determination of water absorption.
- (2) The test methods for Fiber reinforcements are to be in accordance with the Guidance specially specified by the Society.
- (3) For glass fiber reinforcements, minimum property values of laminates are to comply with the values specified in **Table 3. (2020)**
- (4) For carbon fiber reinforcements, minimum property values of laminates are to comply with the values specified in **Table 4. (2020)**

**Table 3 Minimum property values of laminates for glass fiber reinforcement (2020) (2023)**

Material type	Property	Min. value
Chopped strand mat	Tensile strength (stress at maximum load)(N/mm <sup>2</sup> )	200Gc+30
	Modulus of elasticity in tension(kN/mm <sup>2</sup> )	15Gc+2.4
Bi-directional reinforcement	Tensile strength (stress at maximum load)(N/mm <sup>2</sup> )	400Gc-10
	Modulus of elasticity in tension(kN/mm <sup>2</sup> )	30Gc-0.5
Uni-directional reinforcement	Tensile strength (stress at maximum load)(N/mm <sup>2</sup> )	1800Gc <sup>2</sup> -1400Gc+510
	Modulus of elasticity in tension(kN/mm <sup>2</sup> )	130Gc <sup>2</sup> -114Gc+39
All	Flexural strength (stress at maximum load)(N/mm <sup>2</sup> )	502Gc <sup>2</sup> +106.8
	Modulus of elasticity in flexure(kN/mm <sup>2</sup> )	33.4Gc <sup>2</sup> +2.2
	Compressive strength (stress at maximum load)(N/mm <sup>2</sup> )	150Gc+72
	Compressive modulus(kN/mm <sup>2</sup> )	40Gc-6
	Interlaminar shear strength(N/mm <sup>2</sup> )	22-13.5Gc (15 above)
	Water absorption(%)	0.3(max.)
	Glass content(% by weight)	As measured
Notes:		
(1) After water immersion, the values shall be a minimum of 75 % of the above.		
(2) Where materials have reinforcement in more than two directions, the requirement will be subject to individual consideration dependent on the construction.		
(3) Gc : glass fraction by weight.		

**Table 4 Minimum property values of carbon fiber laminates (2020)**

Material type	Property	Min. value
Uni-directional reinforcement 0°	Tensile strength (stress at maximum load)(N/mm <sup>2</sup> )	1125
	Modulus of elasticity in tension(kN/mm <sup>2</sup> )	100
	Compressive strength (stress at maximum load)(N/mm <sup>2</sup> )	750
	Compressive modulus(kN/mm <sup>2</sup> )	87.5
	Flexural strength (stress at maximum load)(N/mm <sup>2</sup> )	900
Biaxial reinforcement 0°/90° or ±45°	Tensile strength (stress at maximum load)(N/mm <sup>2</sup> )	625
	Modulus of elasticity in tension(kN/mm <sup>2</sup> )	55
	Compressive strength (stress at maximum load)(N/mm <sup>2</sup> )	415
	Compressive modulus(kN/mm <sup>2</sup> )	48
	Flexural strength (stress at maximum load)(N/mm <sup>2</sup> )	500
Triaxial reinforcement 0°/±45°	Tensile strength (stress at maximum load)(N/mm <sup>2</sup> )	565
	Modulus of elasticity in tension(kN/mm <sup>2</sup> )	45
	Compressive strength (stress at maximum load)(N/mm <sup>2</sup> )	375
	Compressive modulus(kN/mm <sup>2</sup> )	44
	Flexural strength (stress at maximum load)(N/mm <sup>2</sup> )	400
Quadraaxial reinforcement 0°/90°/±45°	Tensile strength (stress at maximum load)(N/mm <sup>2</sup> )	500
	Modulus of elasticity in tension(kN/mm <sup>2</sup> )	42
	Compressive strength (stress at maximum load)(N/mm <sup>2</sup> )	335
	Compressive modulus(kN/mm <sup>2</sup> )	40
	Flexural strength (stress at maximum load)(N/mm <sup>2</sup> )	365
Notes:		
(1) The carbon fiber volume fraction of laminates is to be 50±5%.		

**4. Core materials**

(1) Specific requirements for end-grain balsa

- (A) The supplier is to provide a signed statement that the balsa (*Ochroma lozopus*) is cut to end-grain, is of good quality, being free from unsound or loose knots, holes, splits, rot, pith and corcho, and that it has been treated against fungal and insect attack, shortly after felling, followed by homogenization, sterilization and kiln drying to an average moisture content of no more than 12 per cent.
- (B) The test methods for end-grain balsa are to be in accordance with the Guidance specially specified by the Society
- (C) Minimum property values of end-grain balsa are to comply with the values specified in **Table 5**. However **Table 5** is for the reference. (2020)

**Table 5 Minimum property values of end-grain balsa (for reference)**

Apparent density (kg/mm <sup>3</sup> )	Strength (stress at maximum load)(N/mm <sup>2</sup> )				Shear	Compressive modulus of elasticity (N/mm <sup>2</sup> )		Shear modulus of elasticity (N/mm <sup>2</sup> )
	Compressive		Tensile			Direction of stress		
	Direction of stress					Parallel to grain	Perpendicular to grain	
	Parallel to grain	Perpendicular to grain	Parallel to grain	Perpendicular to grain				
96	5.0	0.35	9.00	0.44	1.10	2300	35.2	105
144	10.6	0.57	14.6	0.70	1.64	3900	67.8	129
176	12.8	0.68	20.5	0.80	2.00	5300	89.6	145

- (2) Specific requirements for rigid foams (PVC, Polyurethane and other types)
- (A) The foam is to be of the closed cell type and compatible with the proposed resin system (e.g. polyester, epoxide, etc.).
  - (B) Foams are to be of uniform cell structure.
  - (C) Data is to be provided on the dimensional stability of the foam by measurement of the shrinkage.
  - (D) The following test data is to be submitted for each type of foam:
    - (a) Density.
    - (b) Tensile strength (stress at maximum load).
    - (c) Tensile modulus of elasticity.
    - (d) Compressive strength (stress at maximum load).
    - (e) Compressive modulus of elasticity.
  - (E) Additionally the compressive properties (see (D) (d) and (e)) are to be determined at a minimum of five points over the temperature range ambient to maximum recommended service or 70 °C, whichever is the greater.
  - (F) The test methods for rigid foams are to be in accordance with the Guidance specially specified by the Society.
  - (G) Minimum characteristics and mechanical properties of rigid expanded foams are to comply with the values specified in **Table 6**.

**Table 6 Minimum characteristics and mechanical properties of rigid expanded foams at 20 °C**

Material	Apparent density (kg/mm <sup>3</sup> )	Strength (stress at maximum load) (N/mm <sup>2</sup> )			Modulus of elasticity (N/mm <sup>2</sup> )	
		Tensile	Compressive	Shear	Compressive	Shear
Polyurethane	96	0.85	0.60	0.50	17.20	8.50
Polyvinylchloride	60					

- (H) Other types of foam will be subjected to individual consideration. A minimum core shear strength of 0.5 N/mm<sup>2</sup> is to be achieved. ⚓

## Annex 2–9 Offshore mooring chain

### 1. Application

These requirements apply to rolled steels, forgings, castings used for the manufacture of offshore mooring chain and accessories.

### 2. Kinds and grades (2017)

Kinds and grades are classified as specified in **Table 1**.

**Table 1 Kinds and grades of material for offshore mooring chain**

Kind of offshore mooring chain	Grade		
	Rolled steels(Bars)	Forgings	Castings
Grade <i>R3</i>	<i>RSBCR3</i>	<i>RSFCR3</i>	<i>RSCCR3</i>
Grade <i>R3S</i>	<i>RSBCR3S</i>	<i>RSFCR3S</i>	<i>RSCCR3S</i>
Grade <i>R4</i>	<i>RSBCR4</i>	<i>RSFCR4</i>	<i>RSCCR4</i>
Grade <i>R4S</i>	<i>RSBCR4S</i>	<i>RSFCR4S</i>	<i>RSCCR4S</i>
Grade <i>R5</i>	<i>RSBCR5</i>	<i>RSFCR5</i>	<i>RSCCR5</i>

### 3. Rolled steel bars

#### (1) Steel manufacture

- (A) The steels are to be manufactured by basic oxygen, electric furnace or such other process as may be specially approved.
- (B) The austenitic grain size is to be 6 or finer in accordance with **ASTM E112** or equivalent grain size index in accordance to **ISO 643**. Measurements for circular sections are to be taken at 1/6 diameter. (2017)
- (C) Steel for bars intended for R 4S and R 5 chain is to be vacuum degassed.
- (D) For R 4S and R 5 the following information is to be supplied by the bar manufacturer to the mooring chain manufacturer and the results included in the chain documentation :
  - (a) Each heat is to be examined for non-metallic inclusions. The level of micro inclusions is to be quantified and assessed in accordance to the national/international standards; to be sure inclusion levels are acceptable for the final product. (2017)
  - (b) A sample from each heat is to be macro etched according to **ASTM E381** or equivalent, to be sure there is no injurious segregation or porosity. (2017)
  - (c) Hardenability data, according to **ASTM A255**, or equivalent, is to be supplied with each heat. (2017)

#### (2) Steel manufacture

The approval will normally be limited up to the maximum diameter equal to that of the chain diameter tested. the rolling reduction ratio is to be recorded and is to be at least 5:1. the rolling reduction ratio used in production can be higher, but should not be lower than that qualified.

#### (3) Deoxidation practice and chemical composition

- (A) (Same as the present Guidance)
- (B) The steelmaker is to submit a specification of the chemical composition of the bar material, which must be approved by the Society and by the chain manufacturer. The steel maker is to confirm by analysis and testing that the specification is met. For Grade *R4*, *R4S* and *R5* chain, the steel is to be contained a minimum of 0.20 % molybdenum. (2017)

#### (4) Mechanical properties

- (A) The mechanical properties of chain bars are to comply with the requirements given in **Table 2**.
- (B) Hydrogen embrittlement test is to be carried out in accordance with the following procedure:
  - (a) One tensile test specimen is to be tested within max. 3 hours after machining. (for 14 mm diameter specimen, the time limit is 1.5 hours) Alternatively, tensile test specimen may be cooled to -60°C immediately after machining and kept at that temperature for a

- period of max. 5 days.
- (b) The other specimen is to be tested after baking at 250°C for 4 hours. (for 14 mm diameter specimen, the time limit is 2 hours)
  - (c) A slow strain rate not exceed  $0.0003S^{-1}$  as far as practicable is used during the entire test, (This is approximately 10 minutes for the 20 mm diameter specimen) and tensile strength, elongation and reduction of area are to be measured.
  - (d) The test result is to comply with the following formula. If the requirement  $Z_{(1)}/Z_{(2)} \geq 0.85$  is not achieved, the bar material may be subjected to a hydrogen degassing treatment after agreement with the Society. New tests are to be performed after degassing. (2017)

$$Z_{(1)} / Z_{(2)} \geq 0.85$$

$Z_{(1)}$  is the reduction of area measured by the test specified in (B) (a)

$Z_{(2)}$  is the reduction of area measured by the test specified in (B) (b)

**Table 2 Mechanical Properties of offshore mooring chain and accessories (2017)**

Kind	Tensile test				Impact test <sup>(1)</sup>	
	Yield strength (N/mm <sup>2</sup> ) <sup>(2)</sup>	Tensile strength (N/mm <sup>2</sup> ) <sup>(2)</sup>	Elongation(%) ( $L=5d$ )	Reduction of area (%)	Test temp (°C)	Average absorbed energy (J)
<i>R3</i>	410 min.	690 min.	17 min.	50 min.	-20 <sup>(3)</sup>	40 min. <sup>(3)</sup>
<i>R3S</i>	490 min.	770 min.	15 min.	50 min.	-20 <sup>(3)</sup>	45 min. <sup>(3)</sup>
<i>R4</i>	580 min.	860 min.	12 min.	50 min.	-20	50 min.
<i>R4S</i>	700 min.	960 min.	12 min.	50 min.	-20	56 min.
<i>R5</i>	760 min.	1000 min.	12 min.	50 min.	-20	58 min.

NOTES:

- (1) When the absorbed energy of two or more test specimens among a set of test specimens is less in value than the specified average absorbed energy or when the absorbed energy of a single test specimen is less in value than 70 % of the specified average absorbed energy, the test is considered to have failed.
- (2) The yield ratio (the aim value of yield to tensile ratio) for grade *R3*, *R3S*, or *R4* is to be maximum 0.92.
- (3) Impact test of grade *R3* and *R3S* may be carried out at the temperature of 0°C where approved by the Society. In this case, minimum mean absorbed energy is to be not less than 60J for grade *R3* and 65J for grade *R3S*.
- (4) Reduction of area of cast steel is to be for Grades *R3* and *R3S* : min. 40 %, for *R4*, *R4S* and *R5* : min. 35 %.
- (5) Aim maximum hardness for *R4S* is HB330 and *R5* HB340.

**(5) Selection of test sample**

Bars of the same nominal diameter are to be presented for test in batches of 50 tonnes or fraction thereof from the same heat. Test specimens are to be taken from material heat treated in the same manner as intended for the finished chain. Each heat of kind *R3S*, *R4*, *R4S* and *R5* is to be tested for hydrogen embrittlement. (2017)

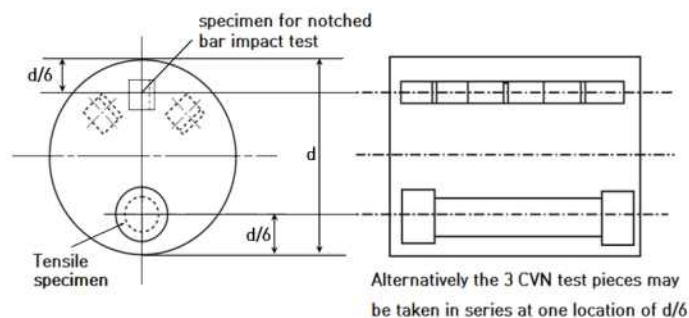
**(6) Test specimens**

(A) For all grades, one tensile and three Charpy V-notch specimens are to be taken from each sample selected.

(B) For grades *R3S*, *R4*, *R4S* and *R5* in addition to the test specimen required by (A), two tensile test specimens having a diameter of 20 mm in principle, are to be taken for the hydrogen embrittlement test. (Consideration will be given to a diameter of 14 mm with the Society's approval.) In this case, test specimen is to be taken from the central region of bar materials heat-treated in the same manner as (a) or (b).

(a) In case of continuous casting, test samples representing both the beginning and the end

- of the charge(except the mixed zone of the charge) shall be taken.
- (b) In case of ingot casting test samples representing two different ingots shall be taken.
- (C) The test specimens are to be taken with their longitudinal axis parallel to the final direction of rolling.
- (D) The tensile and impact test specimens are to be taken from the test sample in the longitudinal direction at a depth of  $1/6$  diameter from the surface or as close as possible to this position. (See **Fig 1**)
- (E) The longitudinal axis of the notch is to correspond approximately to the radial direction of each test specimen.



**Fig 1 Location of test specimens (2017)**

**(7) Surface inspection, non-destructive inspection and verification of dimensions**

- (A) Non-destructive examination is to be performed in accordance with recognized standards such as those indicated below or equivalent. Non-destructive examination procedures, together with rejection/acceptance criteria are to be submitted to the Society. (2017)
- (a) Magnetic particle testing(MT) of bars : *ASTM E1444* and *ISO 9934*
- (b) Magnetic Leakage Flux Testing(MLFT) : *JIS Z2319*
- (c) Eddy current testing(ET) of bars : *ISO 15549:2019 (2023)*
- (B) Manufacturers are to be prepared written procedures for NDT. NDT personnel is to be qualified and certified according to *ISO 9712*, *ACCP* or equivalent. Personnel qualification to an employer or responsible agency based qualification scheme as *SNT-TC-1A* may be accepted if the employer's written practice is reviewed and found acceptable and the Level III is *ASNT Level III*, *ISO 9712 Level III* or *ACCP Professional Level III* and certified in the applicable method. NDT operators are to be qualified to at least level II. (2017)
- (C) All bars supplied in a machined (peeled) condition are to be 100 % visually inspected. The Society may also require: 10 % inspected with magnetic particle testing (MT) or eddy current testing (ET) or Magnetic Leakage Flux Testing (MLFT), for longitudinal imperfections. The maximum depth of peeling is to be agreed and documented in the approval of each supplier. (2017)
- (D) For all grades, 100 percent of round bars for chains is to be examined by magnetic particle(MT) or eddy current(ET) or Magnetic Leakage Flux Testing(MLFT) methods and it is to be confirmed by magnetic particle or eddy current methods and it is to be confirmed that there are no harmful defects. Provided that their depth is not greater than 1 % of the bar diameter longitudinal discontinuities may be removed by grinding and blending to a smooth contour. (2017)
- (E) The manufacturer is to be ensured that 100 percent of bar material intended for either chain or fittings is to be subjected to ultrasonic examination at an appropriate stage of the manufacture to procedures approved by the Society and to the acceptance criteria required. The bars are to be free of pipe, cracks and flakes. If the end length of the delivered bars is not subjected to UT then it must be agreed between the bar supplier and the chain manufacturer of what length of bar is to be removed from the ends. The details are to be documented in the approval of each bar supplier. Phased array UT procedures may be applied, subject to approval by the Society. (2017)
- (F) Notwithstanding the requirements of (D) and (E), the frequency of non-destructive inspection may be reduced where the quality control conditions of the manufacturer are satisfactorily



met.

- (G) The diameter and roundness of all grades of chain bars are to be within the tolerances specified in **Table 3**.

**Table 3 Dimensional tolerance (2017)**

Nominal Diameter (mm)	Tolerance on diameter (mm)	Tolerance on roundness ( $d_{max} - d_{min}$ ) (mm) <sup>(1)</sup>
less than 25	-0, +1.0	0.6 max.
25 ~ 35	-0, +1.2	0.8 max.
36 ~ 50	-0, +1.6	1.1 max.
51 ~ 80	-0, +2.0	1.50 max.
81 ~ 100	-0, +2.6	1.95 max.
101 ~ 120	-0, +3.0	2.25 max.
121 ~ 160	-0, +4.0	3.00 max.
161 ~ 222	-0, +5.0	4.00 max.

NOTES:  
(1)  $d_{max}$  and  $d_{min}$  mean the maximum and minimum diameter of a round bar.

(H) Weld repair of bar is not permitted. (2017)

**(8) Marking**

Each bar is to be stamped with the steel grade designation and the charge number or a code indicating the charge number) on one of the end surfaces. Other marking methods may be accepted with the Society's approval.

**4. Forged steel**

**(1) Manufacture**

- (A) Forged steels used for the manufacture of accessories must be in compliance with approved specifications and the submitted test reports by the Society.
- (B) Steel is to be manufactured by basic oxygen, electric furnace or such other process as may be specially approved.
- (C) The austenitic grain size is to be 6 or finer in accordance with *ASTM E112* or equivalent grain size index in accordance to *ISO 643*. Measurements for circular sections are to be taken at 1/6 diameter. Measurements for non-circular sections are to be taken at 1/4t. (2017)
- (D) Steel for forgings intended for *R4S* and *R5* chain is to be vacuum degassed.
- (F) For steel intended for *R4S* and *R5* accessories the following information is to be supplied by the steel manufacturer to the mooring accessory manufacturer and the results included in the accessory documentation :
- (a) Each heat is to be examined for non-metallic inclusions. The level of micro inclusions is to be quantified and assessed in accordance with the national/international standards; to be sure inclusion levels are acceptable for the final product. (2017)
- (b) A sample from each heat is to be macro etched according to *ASTM E381* or equivalent, to be sure there is no injurious segregation or porosity. (2017)
- (c) Hardenability data, according to *ASTM A255* or equivalent, is to be supplied with each heat. (2017)

**(2) Steel manufacture**

- (A) Forgings are to have wrought microstructure and the minimum reduction ratio is to be 3 to 1. (2017)
- (B) For forgings, the forging reduction ratio, used in the qualification tests, from cast ingot/slab to forged component is to be recorded. The forging reduction ratio used in production can be higher, but should not be lower than that qualified.
- (C) The degree of upsetting during qualification is to be recorded and maintained during production. (2017)
- (D) Heat cycling during forging and reheating is to be monitored by the manufacturer and re-

- corded in the forging documentation. (2017)
- (E) The manufacturer is to have a maintenance procedure and schedule for dies and tooling which is to be submitted to the Society. (2017)
- (3) **Deoxidation practice and chemical composition**
- (A) All steels are to be killed and fine grain treated. The chemical composition of ladle samples of each heat is to be determined by the steel maker and is to comply with the approved specification.
- (B) The forge is to submit a specification of the chemical composition of the forged material, which must be approved by the Society. For Grade *R4*, *R4S* and *R5* chain the steel should contain a minimum of 0.20 % molybdenum.
- (4) **Heat treatment**
- Finished forgings are to be properly heat treated in compliance with specifications submitted and approved. The quench bath maximum temperature and the maximum heat treatment transfer times from furnace to quench are to be established and documented. During production the established quenching parameters are to be followed and records are to be maintained of bath temperatures and transfer times. (2017)
- (5) **Mechanical properties**
- The mechanical properties of each grade are to comply with the requirements given in 2 (4). (2017)
- (6) **Test specimens**
- (A) For test sampling, forgings of similar dimensions (diameters do not differ by more than 25 mm) originating from the same heat treatment charge and the same heat of steel are to be combined into one test unit.
- (B) One tensile test specimen and one set (3 pieces) of impact test specimens are to be taken from the test sample.
- (C) The location of the test specimens is to comply with **Fig 1**.
- (7) **Surface inspection, non-destructive inspection and repair**
- (A) Surface inspection for all grades is to be carried out and it is to be confirmed that there are no harmful defects.
- (B) Non-destructive examination is to be performed in accordance with recognized standards, such as those indicated below, or equivalent. Non-destructive examination procedures, together with rejection/acceptance criteria are to be submitted to the Society. (2017)
- (a) Magnetic particle testing (MT) of forgings : *EN 10228-1*, *ASTM A275*, using wet continuous magnetization technique (2017)
- (b) Ultrasonic testing (UT) of forgings : *EN 10228-3*, *ASTM A388*, *ISO 15549* (2017)
- (C) Non-destructive examination operators are to have the qualification given in 2 (7) (B) in the method of non-destructive examination. (2017)
- (D) The forgings are to be subjected to one hundred percent ultrasonic examination at an appropriate stage of manufacture and in compliance with the standard submitted and approved. (2017)
- (E) Defects on non-machined surfaces may be removed by grinding to a depth of 5% of the nominal diameter. Grinding is not permitted on machined surfaces, except for slight inspection grinding on plane surfaces to a maximum depth of 0.8 mm in order to investigate spurious indications. (2017)
- (F) Welding repairs are not permitted. (2017)
- (8) **Marking**
- Marking of forgings is to be in accordance with 2 (8).

## 5. Steel castings for chains

- (1) **Manufacture**
- (A) Cast steels used for the manufacture of accessories must be in compliance with approved specifications and the submitted test reports by the Society.
- (B) Steel is to be manufactured by basic oxygen, electric furnace or such other process as may be specially approved.
- (C) The austenitic grain size is to be 6 or finer in accordance with *ASTM E112* or equivalent grain size index in accordance to *ISO 643*. Measurements for circular sections are to be taken at 1/6 diameter. Measurements for non-circular sections are to be taken at 1/4t. (2017)
- (D) Steel for castings intended for *R4S* and *R5* chain is to be vacuum degassed.
- (E) For steel intended for *R4S* and *R5* accessories the following information is to be obtained and the results included in the accessory documentation :

- (a) Each heat is to be examined for non-metallic inclusions. The level of micro inclusions is to be quantified and assessed in accordance to the national/international standards; to be sure inclusion levels are acceptable for the final product. (2017)
  - (b) A sample from each heat is to be macro etched according to *ASTM E381* or equivalent, to be sure there is no injurious segregation or porosity. (2017)
  - (c) Hardenability data, according to *ASTM A255* or equivalent, is to be supplied with each heat. (2017)
- (2) **Deoxidation practice and chemical composition**
- (A) All steels are to be killed and fine grain treated. The chemical composition of ladle samples of each heat is to be determined by the steel maker and is to comply with the approved specification.
  - (B) The foundries is to submit a specification of the chemical composition of the cast material, which must be approved by the Society. For Grade *R4*, *R4S* and *R5* chain the steel should contain a minimum of 0.20 % molybdenum.
- (3) **Heat treatment**
- All castings are to be properly heat treated in compliance with specifications submitted and approved by the Society. The quench bath maximum temperature and the maximum heat treatment transfer times from furnace to quench are to be established and documented. During production the established quenching parameters are to be followed and records are to be maintained of bath temperatures and transfer times. (2017)
- (4) **Mechanical properties**
- The mechanical properties of each grade are to comply with the requirements given in **Table 2**. The acceptance requirement for reduction of area is, however, reduced to 40 percent for grades *R3* and *R3S* and 35 percent for grades *R4*, *R4S* and *R5*. (2017)
- (5) **Test specimens**
- (A) For test sampling, castings of similar dimensions originating from the same heat treatment charge and the same heat of steel are to be combined into one test unit.
  - (B) One tensile test specimen and one set (3 pieces) of impact test specimens are to be taken from the test sample.
  - (C) The location of the test specimens is to comply with **Fig 1**.
- (6) **Surface inspection, non-destructive inspection and repair (2017)**
- (A) Surface inspection for all grades is to be carried out and it is to be confirmed that there are no harmful defects.
  - (B) Non-destructive examination is to be performed in accordance with recognized standards, such as those indicated below or equivalent. The non-destructive examination procedures, together with rejection/acceptance criteria are to be submitted to the Society. (2017)
    - (a) Magnetic particle testing(MT) of castings : *ASTM E709*, using wet continuous magnetization technique (2017)
    - (b) Ultrasonic testing(UT) of castings : *ASTM A609*, *ISO 13588* (2017)
  - (C) Non-destructive examination operators are to have the qualification given in **2 (7) (B)** in the method of non-destructive examination. (2017)
  - (D) The castings are to be subjected to 100 percent ultrasonic examination in compliance with the standard submitted and approved.
  - (E) Defects on non-machined surfaces may be removed by grinding to a depth of 5% of the nominal diameter. Grinding is not permitted on machined surfaces, except for slight inspection grinding on plane surfaces to a maximum depth of 0.8 mm in order to investigate spurious indications. (2017)
  - (F) Where the repair entails removal of more than 5% of the diameter or thickness, the defective area is to be repaired by welding. The excavations are to be suitably shaped to allow good access for welding. The resulting grooves are to be subsequently ground smooth and complete elimination of the defective material is to be verified by NDT. (2017)
  - (G) Weld repairs are classified as major or minor. A weld repair is considered major when the depth of the groove prepared for welding exceeds 25 % of the diameter/thickness or 25 mm, whichever is smaller. All other weld repairs are considered minor. (2017)
  - (H) Major weld repairs require approval before the repair is commenced. Proposals for major repairs are to be accompanied by sketches or photographs showing the extent and positions of the repairs. A grain refining heat treatment is to be given to the whole casting prior to major repairs. A post weld heat treatment or repeat of original heat treatment of castings is to be carried out. (2017)

- (I) Minor and major weld repairs must be recorded on sketches or photographs showing the extent and positions of the repairs. (2017)
  - (J) All weld repairs are to be done by qualified welders using qualified procedures. Welders are to be qualified according to *ISO 9606*, *ASME IX*, *ASTM A488* or equivalent. Procedures are to be qualified according to *ISO 15614*, *ASME IX*, *ASTM A488* or equivalent with the following additional requirements: Charpy V notch impact tests with notch locations as below. Test results are to be met the requirements specified for the parent metal. (2017)
    - Weld metal
    - on Fusion line
    - in heat affected zone(HAZ), 2 mm from fusion line
    - in heat affected zone(HAZ), 5 mm from fusion line
- (7) **Marking**  
Marking of forgings is to be in accordance with 2 (8).

#### 6. Materials for studs

- (1) Studs intended for stud link chain cable are to be made of steel corresponding to that of the chain or in compliance with specifications submitted and approved.
- (2) The carbon content should not exceed 0.25 percent if the studs are to be welded in place. ⚓

## Annex 2-10 Hull Structural Steels with Improved Fatigue Properties

### 1. Application

- (1) This requirements apply to hull structural steels with improved fatigue properties(hereinafter called "fatigue resistant steels").
- (2) The requirements other than those specified in this Guidance are applicable to the requirements in **Pt 2, Ch 1, 301.** of the Rules.
- (3) The approval of fatigue resistant steels with specified minimum yield strength of over 390 N/mm<sup>2</sup> is at the discretion of the Society.

### 2. Definitions

Fatigue resistant steels in this Guidance are defined as hull structural steels complying with the following :

- (1) The requirements for the hull structural steels of the corresponding grade specified in **Pt 2, Ch 1, 301.** of the Rules.
- (2) The requirements for fatigue properties specified in **Annex 2-10, 4 (2)** of this Guidance.
- (3) In relation to the above (2), the fatigue life of transverse non-load-carrying fillet welded joint and longitudinal fillet welded gusset is two(2) times longer than that of non-fatigue resistant hull structural steels at specific stress ranges corresponding to the N<sub>f</sub> (number of cycles to failure) of 2x10<sup>6</sup> cycles based on the basic design S-N curve of U.K. DEn in IACS Recommendation No. 56.

### 3. Weld ability

- (1) The weld ability of fatigue resistant steels is similar to those given in **Pt 2, Ch 1, 301.** of the Rules.
- (2) But the additional welding procedure qualification for the fatigue resistant steels may be required according to **Pt 2, Ch 2, Sec. 4** and **Sec. 6** of the Rules.

### 4. Additional requirements related to fatigue properties

#### (1) Manufacturing approval

- (A) Fatigue resistant steels are to be manufactured at works which have been approved by the Society for the grade of steels (including the suffix) which is being supplied.
- (B) Manufacturing approval is to be carried out in accordance with the requirements of **Pt 2, Ch 1, 301.** of the Rules together with the requirements of **the Guidance for Approval of Manufacturing Process and Type Approval, Etc..**

#### (2) Fatigue properties

- (A) The fatigue properties of the welded joints of fatigue resistant steels is to comply with the S-N curves shown in **Fig 1.** The said S-N curves are represented by linear relationships between  $\log(\Delta\sigma)$  and  $\log(N_f)$  as follows:

$$\log(N_f) = \log(K) - m \cdot \log(\Delta\sigma)$$

N<sub>f</sub> : Number of cycles to failure;

K : Constant related to S-N curve, as given in **Table 1**;

m : Negative inverse slope of the S-N curve, as given in **Table 1**;

$\Delta\sigma$ : Stress range (N/mm<sup>2</sup>)

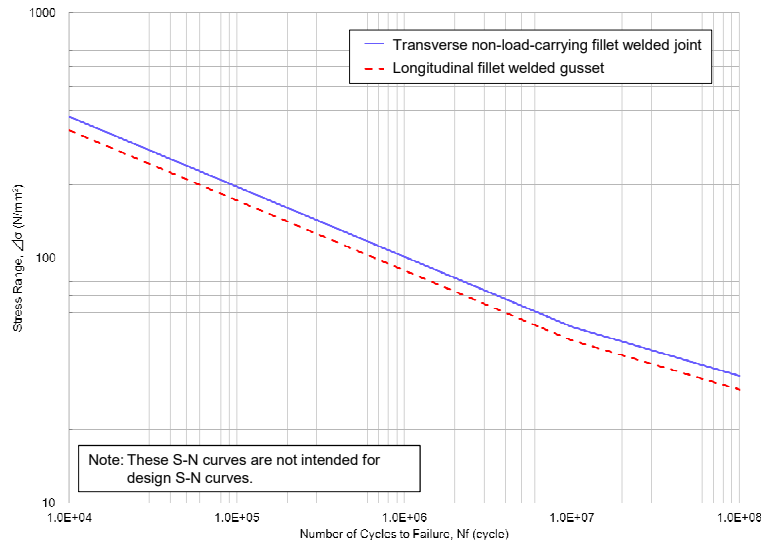


Fig 1 Required fatigue properties(S-N curve in-air environment)

Table 1 Minimum Acceptable Parameters of S-N curve in-air environment

Kind of joints	$N_f \leq 10^7$		$N_f > 10^7$	
	m	K	m	K
Transverse non-load-carrying fillet welded joint <sup>(1)</sup>	3.5	$1.0425 \times 10^{13}$	5.0	$3.9505 \times 10^{15}$
Longitudinal fillet welded gusset <sup>(2)</sup>	3.5	$6.6538 \times 10^{12}$	5.0	$2.0821 \times 10^{15}$

NOTE:  
 (1)  $N_f$  corresponding to  $\Delta\sigma$  of 70 N/mm<sup>2</sup> is  $3.63 \times 10^6$  and  $N_f$  corresponding to  $\Delta\sigma$  of 150 N/mm<sup>2</sup> is  $2.50 \times 10^5$ (refer to **Table 2**).  
 (2)  $N_f$  corresponding to  $\Delta\sigma$  of 70 N/mm<sup>2</sup> is  $2.32 \times 10^6$  and  $N_f$  corresponding to  $\Delta\sigma$  of 150 N/mm<sup>2</sup> is  $1.60 \times 10^5$ (refer to **Table 2**).

(B) The attention must be drawn to the fact that fatigue properties of welded joints are sensitive to items related to design and fabrication.

5. Testing and Inspection related to Fatigue Properties

(1) Test Samples

- (A) All materials in a batch presented for fatigue tests in production tests are to be of the same product form e.g. plates, flats, sections, etc. from the same cast and in the same condition of supply.
- (B) The test samples are to be fully representative of the material. In the case where off-line heat treatment such as “normalizing” and “tempering after accelerated cooling” is applied to the material, test samples are not to be cut from the test piece until the said heat treatment is completed. The position of the samples in the width of the product is to be in accordance with **Pt 2, Ch 1, 301.** of the Rules.
- (C) The test specimens are to be prepared with their longitudinal axes parallel to the final direction of rolling.

(2) Fatigue Test Specimens

- (A) Dimensions of fatigue test specimens are to comply with **Fig 3** in general.
- (B) Welding of test specimens is to be carried out in the presence of the Surveyor, if deemed necessary by the Society.
- (C) It is recommended that the shape of weld metal is measured by an appropriate method be-

- fore testing, and its representative values and/or measured values (e.g. leg length, throat thickness, flank angle) are to be included in the test report (refer to Fig 2).
- (D) For steels of over 22 mm in thickness, thickness of the test specimens is to be reduced to 22 mm from one surface. In the case where the thickness of the fatigue test specimens are reduced, it is recommended to carry out grinding on the reduced side in order to prevent the fatigue crack initiation from the reduced side.
  - (E) Welding consumables approved by the Society are to be used. The welding consumables which could improve the fatigue properties of welded joints (e.g. Low transformation temperature welding consumable) are not to be used. The welding procedure for the fabrication of test specimens is to be as far as possible in accordance with the normal welding practice used at the shipyards for the type of steel in question.
  - (F) In addition, any post-weld treatment improving fatigue properties of the welded joints is not to be carried out. In the case where any item improving the said fatigue properties intentionally (e.g. weld bead with too large flank angle) is found by the Surveyor, re-welding of test specimens may be required.
  - (G) Visual Testing, Magnetic particle Testing or Penetrant Testing may be required after welding at the discretion of the Society.
  - (H) In order to reduce the bending stress due to angular deformation of the test specimen, the amount of angular deformation of the test piece is preferably to be controlled at 5/1000 or less (refer to Fig 4). In the case where the angular deformation of the test specimen is to be corrected, the correction is not to be performed on the weld metal and its proximity.

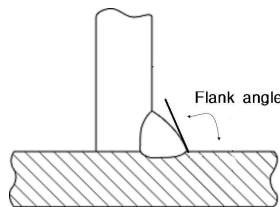


Fig 2 Flank angle

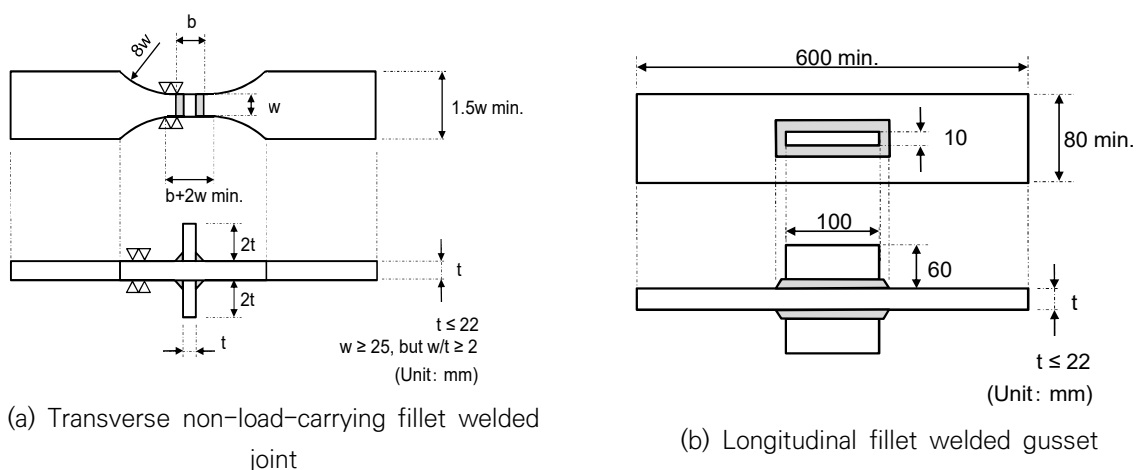


Fig 3 Dimensions of fatigue test specimens

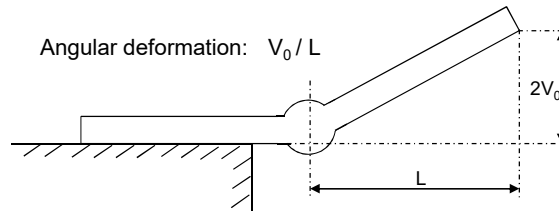


Fig 4 Angular deformation of test specimen

(3) **Number of Fatigue Test Specimens**

- (A) For each batch presented, unless otherwise agreed by the Society, one(1) test sample is to be taken from the test piece unless the weight of the products is greater than 300 tons or fraction thereof.
- (B) One(1) set of two(2) fatigue test specimens is to be prepared from one(1) test sample. Each of two(2) stress ranges shown in **Table 2** is to be tested, respectively.
- (C) The piece selected for the preparation of the test sample is to be the thickest in each batch. The number of fatigue test specimens in the product inspection tests may be increased at the discretion of the Society.

(4) **Fatigue Tests**

- (A) The fatigue tests are to be carried out before dispatch. Test conditions shown in **Table 2** are to be satisfied at least. Test conditions other than **Table 2** are to comply with a recognized national or international standard.

Table 2 Fatigue test conditions

Kind of joints	Stress ratio $R (= \sigma_{\min}/\sigma_{\max})$	Max. stress $\sigma_{\max}$	Stress range $\Delta\sigma$ (N/mm <sup>2</sup> )	
			70 <sup>(2)</sup>	150 <sup>(2)</sup>
Transverse non-load-carrying fillet welded joint	-	$R_{eH}^{(1)}$	70 <sup>(2)</sup>	150 <sup>(2)</sup>
Longitudinal fillet welded gusset	0.1	-		
NOTE: (1) $R_{eH}$ : specified minimum yield strength of the test steel (2) Required min. $N_f$ for these stress ranges are shown in Notes of <b>Table 1</b> . (3) The loading frequency without heat generation is to be selected.				

- (B) It is recommended that the fatigue tests are continued until the failure of the test specimens.
  - (C) All the test specimens are to be selected and stamped by the Surveyor and tested in his presence, unless otherwise agreed.
  - (D) Alternative tests other than fatigue tests in consideration of the relevant improvement mechanism of the fatigue properties may be accepted subject to the approval by the Society based on the satisfactory technical background concerned.
- (5) **Kind of Joints for Fatigue Tests**  
The kind of welded joints for fatigue tests (refer to **Table 2**) are to be agreed between the steel manufacturer and the purchaser, unless otherwise specified by the Society.
- (6) **Retest Procedures**
- (A) Where the fatigue test specimens for two(2) stress ranges fail to satisfy the specified fatigue properties together, the batch is to be rejected. Where the  $N_f$ (number of cycles to failure) of the fatigue test is less than 70 % of the specified fatigue properties, re-testing is not allowed and the batch is to be rejected.
  - (B) Where one of the fatigue test specimens fails to satisfy the specified fatigue properties, two(2) additional test specimens for the stress range concerned may be taken from the same batch of steels for re-testing. In the re-testing, if both of these additional specimens are tested with satisfactory results, the batch may be accepted.



## 6. Marking

The suffix “-FR” is to be affixed to the corresponding grade of hull structural steels defined in **Pt 2, Ch 1, 301.** of the Rules (e.g. *EH 36 FR*).

## 7. Test certificates

In addition to the particulars specified in **Pt 2, Ch 1, 107.** of the Rules, the relevant test certificates are to contain the acceptance and the kind of welded joints of fatigue tests in the production tests.  
↓

## Annex 2-11 High manganese austenitic steels (2020)

### 1. Application

- (1) This Guidance applies to the high manganese austenitic steel plate (hereinafter referred to as "high manganese austenitic steel") for cargo tank in ships carrying liquefied gases in bulk or for fuel tank in ships using low-flash point fuels. Application is suitable for the following cargoes and/or fuels if authorized by the IGC and IGF Codes: (2023)
  - (A) Butane (all isomers)
  - (B) Butane-propane mixture
  - (C) Carbon Dioxide (High Purity and reclaimed quality)
  - (D) Ethane
  - (E) Ethylene
  - (F) Methane (LNG)
  - (G) Pentane (all isomers)
  - (H) Propane
- (2) The high manganese austenitic steel used for purposes other than (1) may be applied this Guidance with the approval of the Society.
- (3) The requirements other than those specified in this Guidance are comply with the requirements specified in **Pt 2, Ch 1, 301.** of the Rules.

### 2. Definitions

- (1) High manganese austenitic steel is the steel with a high amount of manganese in order to retain austenite as its primary phase at atmospheric and service temperature.
- (2) Controlled cooling is a method of cooling from high temperature in accordance with designed cooling rate.

### 3. Manufacturing process

- (1) The reduction ratio of slab to finished product thickness should be not less than 3:1. (2023)
- (2) The grade, thickness, deoxidation practice and chemical composition are to comply with the requirements given in **Table 1.**

**Table 1 Grade, Thickness, Deoxidation Practice and Chemical Composition (2021) (2023)**

Grade	Thickness, $t$ (mm)	Deoxidation Practice	Chemical Composition (%)								
			$C$	$Si^{(1)}$	$Mn$	$P$	$S$	$Cu$	$Cr$	$N$	$B$
HMA400	$6 \leq t \leq 40$	Killed and Fine grain treated	0.35 ~	0.10 ~	22.50 ~	0.030	0.010	0.30 ~	3.00 ~	0.050	0.005
			0.55	0.50	25.50	max.	max.	0.70	4.00	max.	max.

NOTES:

- (1) The content of other elements used for alloying and fine grain treatment may be specified by steelmaker, as appropriate.
- (2) Silicon(Si) may be less than 0.10 %, provided total aluminum is 0.03 % or higher, or provided acid soluble aluminum is 0.025 % or higher.

### 4. Heat treatment

- (1) The heat treatment for high manganese austenitic steel is to be hot rolled and subsequent controlled cooling as necessary.
- (2) Heat treatment following the final rolling process is not permitted.

### 5. Selection of test samples

- (1) One test sample is to be taken from every similarly heat treated piece as rolled directly from one slab or ingot.
- (2) The requirements specified in **Pt 2, Ch 1, 301. 6** (4) of the Rules are to be applied to the selection of the test samples.

### 6. Selection of test specimens

- (1) Tensile test specimens are to comply with the requirements shown in (a) to (c) below:
  - (a) Tensile test specimens are to be taken according to the requirements specified in **Pt 2, Ch 1, 301. 7 (2)** of the Rules.
  - (b) Normally flat tensile test specimens are to be prepared in such a manner as to maintain the rolling scale at least at one side.
  - (c) When instead a machined round tensile test specimen is used then the axis must be located at a position lying at a distance of  $t/4$  from the surface or as near as possible to this position.
- (2) Impact test specimens are to be taken according to the requirements specified in **Pt 2, Ch 1, 301. 7 (3)** of the Rules.

### 7. Mechanical properties

The mechanical properties of high manganese austenitic steel plates are classified as specified in **Table 2**.

**Table 2 Mechanical properties for high manganese austenitic steel plates (2023)**

Grade	Tensile test			Impact test		
	Yield Strength ( $N/mm^2$ )	Tensile Strength ( $N/mm^2$ )	Elongation ( $L = 5.65\sqrt{A}$ ) (%)	Test Temp. (°C)	Average Impact Energy(J) min. <sup>(1)</sup>	
					$T^{(2)}$	$L^{(2)}$
<i>HMA400</i>	min. 400	800~970	min. 22	-196	27	41

NOTE:

- (1) When the absorbed energy of two or more test specimens among a set of test specimens is less in value than the specified average absorbed energy or when the absorbed energy of a single test specimen is less in value than 70 % of the specified average absorbed energy, the test is considered to be failed.
- (2) T and L denotes that the longitudinal axis of the test specimen is arranged transverse and longitudinal, respectively, to the final direction of rolling.

### 8. Welding consumables for high manganese austenitic steel

- (1) Where no special requirements are given in **8**, those as specified in **Pt 2, Ch 2, 607.** of the Rules apply in analogous manner.
- (2) Welding consumables are classified as specified in **Table 3**.

**Table 3 Grades and Marks of Welding Consumables (2023)**

Material for TIG welding	Flux cored wire welding	Consumables for submerged welding
<i>RYHMA</i>	<i>RWHMA</i>	<i>RUHMA</i>

- (3) Submerged arc welding consumables which have passed the tests for each welding process are to be appended with the suffixes shown in **Table 4** at the end of their marks.

**Table 4 Marks**

Welding technique	Marks
Multi-run technique	<i>M</i>
Two-run technique	<i>T</i>
Multi-run and Two-run technique	<i>TM</i>

- (4) Deposited metal test  
 (A) Chemical composition  
 (B) Mechanical properties for deposited metal are to comply with the requirements in **Table 5**.

**Table 5 Mechanical properties for Deposited Metal**

Tensile test			Charpy V notch Impact test	
Yield strength (N/mm <sup>2</sup> )	Tensile strength (N/mm <sup>2</sup> )	Elongation (%)	Test temp. (°C)	Average absorbed energy (J)
400 min.	660 min.	22 min.	-196	27 min.

- (5) Butt weld test  
 Mechanical properties for butt weld test are to comply with the requirements in **Table 6**.

**Table 6 Mechanical properties for butt weld test**

Yield strength (N/mm <sup>2</sup> )	Bend test	Charpy V notch Impact test	
		Test temp. (°C)	Average absorbed energy (J)
660 min.	The test specimens are to be capable of withstanding, without crack exceeding 3 mm long on the outer surface of the specimen or other defects.	-196	27 min.

- (6) Fillet weld test  
 Fillet weld test is to be in accordance with the requirements in **Pt 2, Ch 2, 602. 7** of the Rules.

## 9. Welder

- (1) Welders for high manganese austenitic steel are to have a qualification by welder qualification test with high manganese austenitic steel specimen in accordance with **Pt 2, Ch 2, Sec. 5** of the Rules.  
 (2) Welders who engage in welding for high manganese austenitic steel is to have passed qualification test with high manganese austenitic steel.

## 10. Welding procedure qualification tests

- (1) Welding procedure qualification tests for high manganese austenitic steel is to be in accordance with the requirements in **Pt 7, Ch 5, Sec 6** of Rules and **Rules/Guidances for the Classification of Ships Using Low-flashpoint Fuels**.  
 (2) The kinds of test and the number of test for butt welded joints is to be as shown in **Table 7**.

Table 7 Kinds of Test for Plates with Butt Welded Joints (2023)

Grades and material symbols of test specimens		Kinds and number of specimens for test <sup>(1)(2)</sup>						
		Visual insp.	Tensile test	Bend test	Impact test	Macro-structure insp.	Hard. test <sup>(6)</sup>	Non-destructive insp. <sup>(7)</sup>
High manganese austenitic steel	<i>HMA400</i>	Welding positions of whole length	3 <sup>(3)</sup>	2 <sup>(4)</sup>	<sup>(5)</sup>	1	1	Welding positions of whole length
<p>NOTES:</p> <p>(1) Where found necessary by the Society, microscopic test, hardness test and tests other than these may be required.</p> <p>(2) Welding procedure test assembly is in accordance with <b>Fig 2.2.6(RL9N490)</b> of the Rules.</p> <p>(3) Two specimens are to be taken transversely and one specimen is to be taken longitudinally.(See <b>Fig 2.2.6 of the Rules</b>)</p> <p>(4) Face bend and root bend specimens are used in accordance with <b>Pt 2, Ch 2, 404. 5</b> of the Rules.</p> <p>(5) No. of test sets and position of notch are in accordance with <b>Pt 7, Ch 5, Sec 6</b> of Rules and <b>Rules/Guidances for the Classification of Ships Using Low-flashpoint Fuels</b>.</p> <p>(6) For reference</p> <p>(7) Non-destructive inspection for detection of internal imperfections is, in principle, to be radiographic inspection. Surface inspections by penetrant examination are to be carried out.</p>								

(3) The hardness test of fillet welding is for the reference.

(4) The welding procedure qualification test is carried out considering the following points.

(A) Special attention is to be given to the first root pass when applying flux-cored arc welding (FCAW); reduced amperage is to be considered. And weld gas composition of FCAW may be normally an 80/20 mix of argon and carbon dioxide.

(B) Welding heat input is to be controlled equal to maximum 30 kJ/cm or below.

#### 11. Welding practice

(1) Distance between the weld and nozzle is to be kept to a minimum to reduce the oxygen content at the vicinity of the weld pool.

(2) Appropriate ventilation is to be provided to reduce exposure to hazardous welding fumes.

(3) The edges to be welded are to be smooth, uniform and free from moisture, grease, rust and paint which may cause injurious defects in welded joints.

#### 12. Marking

(1) Steel plates which have satisfactorily complied with the required tests are to be marked with the identification mark in accordance with **Pt 2, Ch 1, 301. 11** of the Rules.

(2) Where the plates are controlled cooling : CC (e.g. : *HMA400 CC*) (2023) ↓

## Annex 2–12 Guidance for advanced non–destructive testing of materials and welds (2021)

### 1. General

#### (1) Application

- (A) This requirements gives minimum requirements on the methods and quality levels that are to be adopted for the advanced non–destructive testing (ANDT) of materials and welds during new building of ships. The ANDT is to be performed by the shipbuilder, manufacturer or its subcontractors in accordance with these requirements. The Society’s surveyor may require witnessing testing.
- (B) It is the shipbuilder’s or manufacturer’s responsibility to ensure that testing specifications and procedures are adhered to during the construction, and the report is to be made available to the Society on the findings made by the ANDT.
- (C) The extent and method of testing, and the number of checkpoints are normally agreed between the shipyard and the Society.

#### (2) Terms and definitions

The following terms and definitions apply for this document.

- (A) ANDT : Advanced non–destructive testing
- (B) RT–D : Digital Radiography
- (C) RT–S : Radioscopic testing with digital image acquisition(dynamic $\geq$  12bit)
- (D) RT–CR : Testing with computed radiography using storage phosphor imaging plates
- (E) PAUT : Phased Array Ultrasonic Testing
- (F) TOFD : Time of Flight Diffraction
- (G) AUT : Automated Ultrasonic Examinations. A technique of ultrasonic examination performed with equipment and search units that are mechanically mounted and guided, remotely operated, and motor–controlled (driven) without adjustments by the technician. The equipment used to perform the examinations is capable of recording the ultrasonic response data, including the scanning positions, by means of integral encoding devices such that imaging of the acquired data can be performed.
- (H) SAUT : Semi–Automated Ultrasonic Examinations. A technique of ultrasonic examination performed with equipment and search units that are mechanically mounted and guided, manually assisted (driven), and which may be manually adjusted by the technician. The equipment used to perform the examinations is capable of recording the ultrasonic response data, including the scanning positions, by means of integral encoding devices such that imaging of the acquired data can be performed.
- (3) **Materials**  
ANT should be applied to the materials in **Pt 2, Ch 1** of the Rules. For other materials, the application is as recognized by the Society.
- (4) **Welding processes**  
These requirements apply to welding processes specified in **Table 1**. ANDT of welding process unspecified in **Table 1** is to be to the satisfaction of the Society.

**Table 1 Applicable welding process**

Welding process		<i>ISO 4063:2009</i>
Manual welding	Shield Metal Arc Welding(SMAW)	111
Resistance welding	Flash welding(FW)	24
Semi–automatic welding	(1) Metal Inert Gas welding(MIG)	131
	(2) Metal Active Gas welding(MAG)	135, 138
	(3) Flux Cored Arc Welding(FCAW)	136
TIG welding	Gas Tungsten Arc Welding(GTAW)	141
Automatic welding	(1) Submerged Arc Welding(SAW)	12
	(2) Electro–gas Welding(EGW)	73
	(3) Electro–slag Welding(ESW)	72

**(5) Welding joints**

These requirements apply to butt welds with full penetration. Variations of joint design, for example, tee, corner and cruciform joints (with or without full penetration) can be tested using PAUT. The constraints of joint design with respect to testing are to be recognized, documented, and agreed with the Society before application.

**(6) Timing of ANDT**

(A) ANDT are to be conducted after welds have cooled to ambient temperature and after post weld heat treatment where applicable.

(B) Timing of ANDT on ship hull welds on steels with specified minimum yield stress in the range of 420 N/mm<sup>2</sup> to 690 N/mm<sup>2</sup> shall be in accordance with 1. (9) of **Annex 2-7**.

**(7) Testing methods**

(A) The methods mentioned in this **Annex** for detection of imperfections are PAUT(only auto-mated / semi-automated PAUT), TOFD, RT-D.

(B) Applicable methods for testing of the different types of materials and weld joints are given in **Table 2**.

Table 2 Applicable methods for testing of materials and weld joints

MATERIALS AND WELD JOINTS	PARENT MATERIAL THICKNESS(t)	APPLICABLE METHODS
Ferritic butt welds with full penetration	$t < 6 \text{ mm}$	RT-D
	$6 \text{ mm} \leq t \leq 40 \text{ mm}$	PAUT, TOFD, RT-D
	$t > 40 \text{ mm}$	PAUT, TOFD, RT-D <sup>(1)</sup>
Ferritic tee joints and corner joints with full penetration	$t \geq 6 \text{ mm}$	PAUT, RT-D <sup>(1)</sup>
Ferritic cruciform joints with full penetration	$t \geq 6 \text{ mm}$	PAUT <sup>(1)</sup>
Austenitic stainless steel butt welds with full penetration <sup>(2)</sup>	$t < 6 \text{ mm}$	RT-D
	$6 \text{ mm} \leq t \leq 40 \text{ mm}$	RT-D, PAUT <sup>(1)</sup>
	$t > 40 \text{ mm}$	PAUT <sup>(1)</sup> , RT-D <sup>(1)</sup>
Austenitic stainless steel tee joints, corner joints with full penetration <sup>(2)</sup>	$t \geq 6 \text{ mm}$	PAUT <sup>(1)</sup> , RT-D <sup>(1)</sup>
Aluminum tee joints and corner joints with full penetration	$t \geq 6 \text{ mm}$	PAUT <sup>(1)</sup> , RT-D <sup>(1)</sup>
Aluminum cruciform joints with full penetration	$t \geq 6 \text{ mm}$	PAUT <sup>(1)</sup>
Aluminum butt welds with full penetration	$t < 6 \text{ mm}$	RT-D
	$6 \text{ mm} \leq t \leq 40 \text{ mm}$	RT-D, TOFD, PAUT
	$t > 40 \text{ mm}$	TOFD, PAUT, RT-D <sup>(1)</sup>
Cast Copper Alloy	All	PAUT, RT-D <sup>(1)</sup>
Steel forgings	All	PAUT, RT-D <sup>(1)</sup>
Steel castings	All	PAUT, RT-D <sup>(1)</sup>
Base materials/Rolled steels, Wrought Aluminum Alloys	$t < 6 \text{ mm}$	RT-D
	$6 \text{ mm} \leq t \leq 40 \text{ mm}$	PAUT, TOFD, RT-D
	$t > 40 \text{ mm}$	PAUT, TOFD, RT-D <sup>(1)</sup>

Note:

(1) Only applicable with limitations, need special qualification subject to acceptance by the Society.

(2) The ultrasonic testing of anisotropic material using advanced methods will require specific procedures and techniques. Additionally, the use of complementary techniques and equipment may also be required, e.g. using angle compression waves, and/or creep wave probes for detecting defects close to the surface.



## 2. Qualification of personnel involved in ANDT

Qualification of personnel is to be accordance with 1. (7) of Annex 2–7.

## 3. Technique and procedure qualification

### (1) General

The shipbuilder or manufacturer has to submit to the Society the following documentation for review.

(A) The technical documentation of the ANDT

(B) The operating methodology and procedure of the ANDT according to 8.

(C) Result of software simulation, when applicable

### (2) Software simulation

Software simulation may be required by the Society, when applicable for PAUT or TOFD techniques. The simulation may include initial test set-up, scan plan, volume coverage, result image of artificial flaw etc.. In some circumstances, artificial defect modeling/simulation may be needed or required by the project.

### (3) Procedure qualification test

The procedure qualification for ANDT system shall include the following steps.

(A) Review of available performance data for the inspection system (detection abilities and defect sizing accuracy)

(B) Identification and evaluation of significant parameters and their variability

(C) Planning and execution of a repeatability and reliability test programme which including onsite demonstration

(D) Documentation of results from the repeatability and reliability test programs

(4) The data from the repeatability and reliability test program specified in (3) (C) above is to be analyzed with respect to comparative qualification block test report and onsite demonstration. The qualification block shall be in accordance with **ASME V Article 14 MANDATORY APPENDIX II UT PERFORMANCE DEMONSTRATION CRITERIA** or agreed by the Society, and at least the intermediate level qualification blocks shall be used. The high level qualification blocks shall be used when sizing error distributions and an accurate POD need to be evaluated. The demonstration process onsite shall be witnessed by the Society's surveyor.

## 4. Procedure approval

The testing procedure is to be evaluated based upon the qualification results, if satisfactory the procedure can be considered approved.

## 5. Onsite review

(1) For the test welds, supplementary NDT shall be performed on an agreed proportion of welds to be cross checked with other methods. Alternatively, other documented reference techniques may be applied to compare with ANDT results.

(2) Data analyses shall be performed in accordance with the above activities. Probability of Detection (PoD) and sizing accuracy shall be established when applicable.

(3) When the result of inspection review does not conform to the approved procedure, the inspection shall be suspended immediately. Additional procedure review qualification and demonstration shall be undertaken to account for any nonconformity.

(4) When a significant nonconformity is found, the Society has the right to reject the results of such activities.

## 6. Surface condition

(1) Area to be examined shall be free from scale, loose rust, weld spatter, oil, grease, dirt or paint that might affect the sensitivity of the testing method.

(2) Where there is a requirement to carry out PAUT or TOFD through paint, the suitability and sensitivity of the test shall be confirmed through an appropriate transfer correction method defined in the procedure. In all cases, if transfer losses exceed 12 dB, the reason shall be considered and further preparation of the scanning surfaces shall be carried out, if applicable. If testing is done through paint, then the procedure shall be qualified on a painted surface.

(3) The requirement for acceptable test surface finish is to ensure accurate and reliable detection of defects. For the testing of welds, where the test surface is irregular or has other features likely to interfere with the interpretation of NDT results, the weld is to be ground or machined.

## 7. General plan of testing: NDT method selection

The extent of testing shall be planned by the shipbuilder or manufacturer according to the ship design, ship or equipment type and welding processes used. Particular attention shall be paid to highly stressed areas.

## 8. Testing requirements

### (1) General

- (A) The shipyard or manufacturer is to ensure that personnel carrying out NDT or interpreting the results of NDT are qualified to the appropriate level as detailed in 2..
- (B) Procedures
  - (a) All NDT are to be carried out to a procedure that is representative of the item under inspection.
  - (b) Procedures are to identify the component to be examined, the NDT method, equipment to be used and the full extent of the examinations including any test restrictions.
  - (c) Procedures are to include the requirement for components to be positively identified and for a datum system or marking system to be applied to ensure repeatability of inspections.
  - (d) Procedures are to include the method and requirements for equipment calibrations and functional checks, together with specific technique sheets/scan plans, for the component under test.
  - (e) Procedures are to be approved by personnel qualified to Level III in the appropriate technique in accordance with a recognised standard.
  - (f) Procedures are to be reviewed by the Society's Surveyor.
- (C) The methods considered within the application defined in 1. (7).
- (D) PAUT techniques shall conform as a minimum to (2). Depending on the complexity of the item under test and the access to surfaces, there may be a requirement for additional scans and/or complementary NDT techniques to ensure that full coverage of the item is achieved.
  - (a) PAUT of welds shall include a linear scan of the fusion face, together with other scans as defined in the specific test technique. Refer to linear scan requirements in (2) (B) (d).
- (E) TOFD techniques shall conform as a minimum to (3). Depending on the complexity of the item under test and the access to surfaces, there may be a requirement for additional scans and/or complementary NDT techniques to ensure that full coverage of the item is achieved.
- (F) RT-D techniques shall conform as a minimum to (4). RT-D comprises of two main RT methods; RT-S and RT-CR. Other methods may be included (e.g. radioscopy systems), however, then must conform to this **Annex** as applicable, and any specific requirements shall demonstrate equivalence to these requirements.
  - (a) In all RT-D methods, in addition to specific requirements, detector output quality control methods shall be described within the procedure.
  - (b) The procedure shall define the level of magnification, post-processing tools, image/data security and storage, for final evaluation and reporting.

### (2) PAUT

PAUT shall be carried out according to procedures based on *ISO 13588:2019*, *ISO 18563-1:2015*, *ISO 18563-2:2017*, *ISO 18563-3:2015* and *ISO 19285:2017* or recognized standards and the specific requirements of the Society.

#### (A) Information required prior to testing

A procedure shall be written and include the following information as in minimum shown in Table 3. When an essential variable in Table 3 is to change from the specified value, or range of values, the written procedure shall require requalification. When a nonessential variable is to change from the specified value, or range of values, requalification of the written procedure is not required. All changes of essential or nonessential variables from the value, or range of values, specified by the written procedure shall require revision of, or an addendum to, the written procedure.

Table 3 Requirements of a PAUT Procedure

Requirement	Essential Variable	Nonessential Variable
Material types or weld configurations to be examined, including thickness dimensions and material product form (castings, forgings, pipe, plate, etc.)	√	
The surfaces from which the examination shall be performed	√	
Technique(s) (straight beam, angle beam, contact, and/or immersion)	√	
Angle(s) and mode(s) of wave propagation in the material	√	
Search unit type, frequency, element size and number, pitch and gap dimensions, and shape	√	
Focal range(identify plane, depth, or sound path)	√	
Virtual aperture size(i.e., number of elements, effective height(1), and element width)	√	
Focal laws for E-scan and S-scan (i.e., range of element numbers used, angular range used, element or angle increment change)	√	
Special search units, wedges, shoes, or saddles, when used	√	
Ultrasonic instrument(s)	√	
Calibration [calibration block(s) and technique(s)]	√	
Directions and extent of scanning	√	
Scanning(manual vs. automatic)	√	
Method for sizing indications and discriminating geometric from flaw indications	√	
Computer enhanced data acquisition, when used	√	
Scan overlap(decrease only)	√	
Personnel performance requirements, when required	√	
Testing levels, acceptance levels and/or recording levels	√	
Personnel qualification requirements		√
Surface condition(examination surface, calibration block)		√
Couplant(brand name or type)		√
Post-examination cleaning technique		√
Automatic alarm and/or recording equipment, when applicable		√
Records, including minimum calibration data to be recorded (e.g., instrument settings)		√
Environmental and safety issues		√
Note: (1) Effective height is the distance from the outside edge of the first to last element used in the focal law.		

- (B) Testing
- (a) Testing levels  
The testing levels specified in the testing procedure shall be in accordance with recognized standards accepted by the Society. Four testing levels are specified in *ISO 13588:2019*, each corresponding to a different probability of detection of imperfections.
- (b) Weld Examinations  
The weld examinations shall in accordance with *ISO 13588:2019* and the additional special requirements of this **Annex**.
- (c) Material Examinations  
Material examinations shall conform to **1. (3)** as a minimum.
- (d) Volume to be inspected
- (i) The purpose of the testing shall be defined by the testing procedure. Based on this, the volume to be inspected shall be determined.
- (ii) A scan plan shall be provided. The scan plan shall show the beam coverage, the weld thickness and the weld geometry.
- (iii) If the evaluation of the indications is based on amplitude only, it is a requirement that an 'E' scan (or linear scan) shall be utilized to scan the fusion faces of welds, so that the sound beam is perpendicular to the fusion face  $\pm 5^\circ$ . This requirement may be omitted if an 'S' (or sectorial) scan can be demonstrated to verify that discontinuities at the fusion face can be detected and sized, using the stated procedure (note, this demonstration shall utilize reference blocks containing suitable reflectors in location of fusion zone).
- (e) Reference blocks  
Depending on the testing level, a reference block shall be used to determine the adequacy of the testing (e.g. coverage, sensitivity setting). The design and manufacture of reference blocks shall be in accordance with *ISO 13588:2019* or recognized equivalent standards and the specific requirements of the Society.
- (f) Indication assessment  
Indications detected when applying testing procedure shall be evaluated either by length and height or by length and maximum amplitude. Indication assessment shall be in accordance with *ISO 19285:2017* or recognized standards and the specific requirements of the Society. The sizing techniques include reference levels, Time Corrected Gain(TCG), Distance Gain Size(DGS) and 6 dB drop. 6 dB drop method shall only be used for measuring the indications larger than the beam width.
- (3) TOFD  
TOFD shall be carried out according to procedure based on *ISO 10863:2011*, and *ISO 15626:2018* or recognized standards and the specific requirements of the Society.
- (A) Information required prior to testing  
A procedure shall be written and include the following information as shown in **Table 4**. When an essential variable in **Table 4** is to change from the specified value, or range of values, the written procedure shall require requalification. When a nonessential variable is to change from the specified value, or range of values, requalification of the written procedure is not required. All changes of essential or nonessential variables from the value, or range of values, specified by the written procedure shall require revision of, or an addendum to, the written procedure.

Table 4 Requirements of a TOFD Procedure

Requirement	Essential Variable	Nonessential Variable
Weld configurations to be examined, including thickness dimensions and material product form (castings, forgings, pipe, plate, etc.)	√	
The surfaces from which the examination shall be performed	√	
Angle(s) of wave propagation in the material	√	
Search unit type(s), frequency(ies), and element size(s)/shape(s)	√	
Special search units, wedges, shoes, or saddles, when used	√	
Ultrasonic instrument(s) and software(s)	√	
Calibration [calibration block(s) and technique(s)]	√	
Directions and extent of scanning	√	
Scanning (manual vs. automatic)	√	
Data sampling spacing (increase only)	√	
Method for sizing indications and discriminating geometric from flaw indications	√	
Computer enhanced data acquisition, when used	√	
Scan overlap (decrease only)	√	
Personnel performance requirements, when required	√	
Testing levels, acceptance levels and/or recording levels	√	
Personnel qualification requirements		√
Surface condition (examination surface, calibration block)		√
Couplant (brand name or type)		√
Post-examination cleaning technique		√
Automatic alarm and/or recording equipment, when applicable		√
Records, including minimum calibration data to be recorded (e.g., instrument settings)		√
Environmental and safety issues		√

- 
- (B) Testing
- (a) Testing levels  
The testing levels specified in the testing procedure shall be in accordance with recognized standards accepted by the Society. Four testing levels are specified in *ISO 10863:2011*, each corresponding to a different probability of detection of imperfections.
- (b) Volume to be inspected
- (i) The purpose of the testing shall be defined by the testing procedure. Based on this, the volume to be inspected shall be determined.
- (ii) A scan plan shall be provided. The scan plan shall show the locations of the probes, beam coverage, the weld thickness and the weld geometry.
- (c) Due to the nature of the TOFD method, there is a possibility that the scan plan may reveal weld volume zones that will not receive full TOFD coverage (commonly known as dead zones, either in the lateral wave, back wall, or both). If the scan plan reveals that these dead zones are not adequately inspected, then further TOFD scans and/or complementary NDT methods shall be applied to ensure full inspection coverage.
- (4) RT-D  
Digital radiography shall be performed per procedure(s) based on *ISO 17636-2:2013* and standards referenced therein, or recognized standards and additional specific requirements of the Society. Any variation to applying the standard (e.g. IQI placement) shall be agreed with Society.
- (A) A procedure shall be written and include the following information as shown in **Table 5**.
- (B) Testing levels  
Regarding choice of testing level per *ISO 17636-2:2013* this is referred to in **9. (4)**.

**Table 5** Requirements of a Digital radiography Procedure

Requirement
Material types or weld configurations to be examined, including thickness dimensions and material product form (castings, forgings, pipe, plate, etc.)
<b>Digitizing System Description:</b>
Manufacturer and model no. of digitizing system
Physical size of the usable area of the image monitor
Film size capacity of the scanning device
Spot size(s) of the film scanning system
Image display pixel size as defined by the vertical/horizontal resolution limit of the monitor
Illuminance of the video display
Data storage medium
<b>Digitizing Technique:</b>
Digitizer spot size (in microns) to be used
Loss-less data compression technique, if used
Method of image capture verification
Image processing operations
Time period for system verification
<b>Spatial resolution used:</b>
Contrast sensitivity (density range obtained)
Dynamic range used
Spatial linearity of the system
Material type and thickness range
Source type or maximum X-ray voltage used
Detector type
Detector calibration
Minimum source-to-object distance
Distance between the test object and the detector
Source size
Test object scan plan (if applicable)
Image Quality Measurement Tools
Image Quality Indicator (IQI)
Wire Image Quality Indicator
Duplex Image Quality Indicator
Image Identification Indicator
Testing levels, acceptance levels and/or recording levels
Personnel qualification requirements
Surface condition
Records, including minimum calibration data to be recorded
Environmental and Safety issues

## 9. Acceptance Levels

### (1) General

(A) This section details the acceptance levels followed for the assessment of the NDT results. Methods include but are not limited to: Phased array ultrasonic testing(PAUT), Time of flight diffraction(TOFD), Digital radiography(RT-D).

(B) It may be necessary to combine testing methods to facilitate the assessment of indications against the acceptance criteria.

### (2) PAUT

(A) The relationship between acceptance levels, testing levels and quality levels is given in **Table 6**. Quality levels and acceptance levels for PAUT of welds shall be in accordance with *ISO 19285:2017* or recognized standard agreed with the Society.

**Table 6 Acceptance levels for PAUT**

Quality levels according to ISO 5817:2014	Testing level according to ISO 13588:2019	Acceptance levels according to ISO 19285:2017
C, D	A	3
B	B	2
By agreement	C	1
Special application	D	By agreement

### (B) Material Examinations

Quality levels and acceptance levels for PAUT of material testing shall be in accordance to recognized standard agreed with the Society. The acceptance levels for material examinations shall conform as a minimum to the appropriate Technical Rules.

### (3) TOFD

The relationship between acceptance levels, testing levels and quality levels is given in **Table 7**. Quality levels and acceptance levels for TOFD of welds shall be in accordance to *ISO 15626:2018* or recognized standard agreed with the Society.

**Table 7 Acceptance levels for TOFD**

Quality levels according to ISO 5817:2014	Testing level according to ISO 10863:2011	Acceptance level according to ISO 15626:2018
B(Stringent)	C	1
C(Intermediate)	At least B	2
D(Moderate)	At least A	3

### (4) RT-D

The relationship between acceptance levels, testing levels and quality levels is given in **Table 8**. Quality levels and acceptance levels for Digital Radiography of welds shall be in accordance with *ISO 10675* or standard agreed with the Society.



Table 8 Acceptance levels for RT-D

Quality levels according to ISO 5817:2014 or ISO 10042:2018	Testing techniques/level(class) according to ISO 17636-2:2013	Acceptance level according to ISO 10675-1:2016 & ISO 10675-2:2017
B(Stringent)	B (class)	1
C(Intermediate)	B <sup>(1)</sup> (class)	2
D(Moderate)	A (class)	3
Notes (1) For circumferential weld testing, the minimum number of exposures may correspond to the requirements of ISO 17636-2:2013, class A		

## 10. Reporting

- (1) The test report shall include at least the information of **Table 9**.
- (2) Results of NDT are to be recorded and evaluated by the shipbuilder or manufacturer on a continual basis. These records are to be available to the Surveyor.
- (3) The shipbuilder or manufacturer is to be responsible for the review, interpretation, evaluation and acceptance of the results of NDT. Reports stating compliance or otherwise with the criteria established in the inspection procedure are to be issued.
- (4) In addition to the above general reporting requirements, all specified NDT methods will have particular requirements and details that shall be listed in the report. Refer to the applicable method standards for specific requirements.
- (5) The shipbuilder or manufacturer is to keep the inspection records for the appropriate period deemed by Society.

## 11. Unacceptable indications and repairs

All indications (discontinuities) exceeding the applicable acceptance criteria shall be classed as defects, and shall be eliminated and repaired as per applicable the Technical Rules.

Table 9 Information for the test report

NDT method	Related parts	Information
All	Standards	a reference to standards of compliance
	The object under test	1) identification of the object under test 2) dimensions including wall thickness 3) material type and product form 4) geometrical configuration 5) location of welded joint(s) examined 6) reference to welding process and heat treatment 7) surface condition and temperature 8) stage of manufacture
	Equipment	manufacturer and type of instrument, including with identification numbers if required.
	Test technology	1) testing level and reference to a written test procedure 2) purpose and extent of test 3) details of datum and coordinate systems 4) method and values used for range and sensitivity settings 5) details of signal processing and scan increment setting 6) access limitations and deviations from standards, if any
	Test results	1) acceptance criteria applied 2) tabulated data recording the classification, location and size of relevant indications and results of evaluation 3) results of examination including data on software used 4) date of test 5) reference to the raw data file(s) 6) date(s) of scan or exposure and test report 7) names, signatures and certification of personnel
PAUT	Equipment	1) manufacturer, type, frequency of phased array probes including number and size of elements, material and angle(s) of wedges with identification numbers if required 2) details of reference block(s) with identification numbers if required 3) type of couplant used
	Test technology	1) increment (E-scans) or angular increment (S-scans) 2) element pitch and gap dimensions 3) focus (calibration should be the same as scanning) 4) virtual aperture size, i.e. number of elements and element width 5) element numbers used for focal laws 6) documentation on permitted wedge angular range from manufacturer 7) documented calibration, TCG and angle gain compensation 8) scan plan
	Test results	1) phased array images of at least those locations where relevant indications have been detected on hard copy, all images or data available in soft format 2) reference points and details of the coordinate system
TOFD	Equipment	1) manufacturer, type, frequency, element size and beam angle(s) of probes with identification numbers if required 2) details of reference block(s) with identification numbers if required 3) type of couplant used
	Test technology	1) details of TOFD setups 2) details of offset scans, if required
	Test results	1) TOFD images of at least those locations where relevant TOFD indications have been detected

Table 9 Information for the test report (Cont'd)

NDT method	Related parts	Information
RT-D	Equipment	1) system of marking used 2) radiation source, type and size of focal spot and identification of equipment used 3) detector, screens and filters and detector basic spatial resolution
	Test technology	1) detector position plan 2) tube voltage used and current or source type and activity 3) time of exposure and source-to-detector distance 4) type and position of image quality indicators 5) achieved and required SNRN for RT-S or achieved and required grey values and/or SNRN for RT-CR 6) for RT-S: type and parameters such as gain, frame time, frame number, pixel size, calibration procedure 7) for RT-CR: scanner type and parameters such as pixel size, scan speed, gain, laser intensity, laser spot size 8) image-processing parameters used, e.g. of the digital filters



Rules for the Classification of Steel Ships  
Guidance Relating to the Rules for the Classification  
of Steel Ships

---

## PART 2 MATERIALS AND WELDING

Published by

**KR**

36, Myeongji ocean city 9-ro, Gangseo-gu,  
BUSAN, KOREA

TEL : +82 70 8799 7114

FAX : +82 70 8799 8999

Website : <http://www.krs.co.kr>

---

Copyright© 2024, **KR**

Reproduction of this Rules and Guidance in whole or in  
parts is prohibited without permission of the publisher.